

Feature Mismatches: Consequences for Syntax, Morphology and Semantics

Peter William Smith, PhD

University of Connecticut, 2015

In this dissertation, I investigate the nature of grammatical features and propose that a grammatical feature is split into two halves: one half (uF) that is legible to the morphological component and one half (iF) that is legible to the semantic component. Though these halves in general match up, the values can be distinct or one can be missing altogether. Throughout the dissertation, I investigate various phenomena where the values of the two halves of the feature do not line up, looking at the mass/count distinction, collective nouns in (British) English, and quantified noun phrases in Russian, among others.

I propose that two classes of atypical mass nouns - fake mass nouns in English and plural mass nouns in Telugu - result from there being a mismatch on the number features of the items, which results in the morphology of the noun having either mass or count behavior (depending on the language), whilst the semantics shows the opposite behavior.

I further look at the nature of AGREE. I look at agreement that targets the iF value of a feature instead of the uF , which leads to semantically motivated agreement, and I show that this has a different, more restricted behavior than morphologically motivated agreement, operating under different structural configurations. Finally, I discuss the Agreement Hierarchy of Corbett (1979, *et seq*), where it appears to hold within a single sentence. I will show that when two targets agree with a hybrid controller, the targets can mismatch with one agreeing with the iF and one with the uF . Not all mismatches are allowed, a fact that is explained through the timing of agreement.

Feature Mismatches: Consequences for Syntax, Morphology and Semantics

Peter William Smith

B.A., University College London, 2010

M.A., University of Connecticut, 2014

A Dissertation

Submitted in Partial Fulfillment of the

Requirements for the Degree of

Doctor of Philosophy

at the

University of Connecticut

2015

Copyright by
Peter William Smith

2015

ii

APPROVAL PAGE

Doctor of Philosophy Dissertation

Feature Mismatches: Consequences for Syntax, Morphology and Semantics

Presented by

Peter William Smith, B.A., M.A.

Major Advisor _____
Susanne Wurmbrand

Major Advisor _____
Jonathan Bobaljik

Associate Advisor _____
Željko Bošković

Associate Advisor _____
Jon Gajewski

University of Connecticut
2015

ACKNOWLEDGMENTS

Though my name alone is on this dissertation, those who have written one know how much of an injustice that is to various other people, who have all contributed but without getting any of the credit.¹ I must first thank the members of my committee, who have guided me through not just the dissertation, but the entirety of the last five years. Jonathan has been a fantastic major advisor and I have always enjoyed working with him, and learning from him, even more so because of the fact that his teaching has always reminded me of Michael Jackson's Thriller dance. He's always been there to listen to my ideas, suggest alternatives and give me extensive comments on everything. Susi has been my major advisor for all my time at UConn, and this thesis really grew out of discussions with her years ago about semantic agreement in British English. She has always encouraged me, supported me and been there to discuss any project with me and give me feedback, and I'm very grateful for all of this. Željko has always given me great feedback, encouragement and suggestions for extensions. His knowledge of syntactic theory (and beyond) is extraordinary, and it was a pleasure to discuss ideas with him. Jon has always been willing to teach me semantics, even though I'm sure the process was excruciatingly slow for him. His perseverance and insightful comments on the topics here have helped me a lot.

I'd also like to thank the linguistics department at UConn, in particular to my year mates Aida and Gísli. Thanks also to those who gave me judgements, and especially Radhika for being a fantastic Telugu consultant. I also thank, and owe a lot to, both

¹Rightly so however, all mistakes are genuinely my own.

Tamara Cohen and Catalina Ritton for helping me wade through UConn's bureaucratic nuances.

One thing I've learned over the last few years is that writing a dissertation is as much about surviving as actually writing the damn thing, and for being able to survive life in Storrs I owe a lot to Jungmin, Leah and Neda. Also special thanks are due to Tamara and Edwin (and Lindi and Chuli!) for giving Beata and I such an amazing time in Sint Maarten, which really took the edge off the final year. Furthermore, Beata and I have spent more time than can reasonably be considered normal over the last couple of years watching Monterey Bay Aquarium's Sea Otter webcam as a welcome distraction from writing, so I owe a debt of gratitude to the aquarium and its staff for offering such a service (and all the wonderful work they do), not to mention the otters themselves, Gidget, Ivy, Rosa, Kit and Abby.

The biggest thanks of all go to those closest to me. Firstly to my best friends Rachel, Adam, Daren and Laura. Though I've been too far away, over the years they have always kept me feeling close to home with all the times they made me laugh and through our long email exchanges and conversations on the all too rare occasions when we see each other (I'm looking at you, Daren).

I keep trying to think of what to say to my parents, but nothing seems good enough. They have always given me constant love and support in all that I do, and so much of where I am in life is due to them. Thank you so incredibly much Mum and Dad, for putting me on the path to where I am today, and for being there for me along every bit of the way.

Finally, there's one person above all without who this wouldn't have been possible, my wife Beata. It's genuinely true that without her, this dissertation wouldn't have happened,

and no matter which words I would use in thanks here to her, they wouldn't be anywhere close to being sufficient to express just how much she has meant to me throughout this whole silly process. Beata, thank you for everything, above all for just being you. We did it!

This thesis is for my parents Kevin and Beth Smith.

I really can't thank them enough.

Just 'cause I said it, don't mean that I meant it.

- Adele, Rumour Has It

Contents

1	Towards a theory of split features	1
1.1	Mismatches between morphology and semantics	2
1.1.1	Grammatical Gender	2
1.1.2	Imposters	3
1.1.3	Unagreement	4
1.2	Features that match, and ones that do not	4
1.2.1	A minimalist approach to feature mismatches	4
1.3	Overview of the Dissertation	6
2	Atypical mass nouns	12
2.1	Introduction	12
2.1.1	Mass versus count: A general overview	12
2.1.2	Mass versus count	15
2.2	‘Fake’ mass nouns in English	22
2.2.1	Fake-mass nouns are atypical mass nouns	22
2.2.2	How fake mass nouns have been incorporated into the theory of mass versus count	24
2.2.3	The effect of inherent number	25
2.2.4	Count-mass nouns are imposters, masquerading as mass nouns	27
2.2.5	What about quantifiers?	38
2.2.6	Fake mass nouns, woodchippers, and the Universal Grinder	41
2.2.7	Interim Summary	43
2.3	Non-countable count nouns in Telugu	43
2.3.1	The mass/count distinction in Telugu	43
2.3.2	Milk and water: Plural mass nouns in Telugu	47
2.3.3	Quantifier allomorphy again	54
2.3.4	Conclusions	56
2.4	Mass/count quantifiers as allomorphy	56

2.4.1	Plural mass nouns in English	57
2.4.2	Quantifier selection in Purépecha	64
2.4.3	Nouns that lie in the middle	66
2.5	The Typology of Inherent Features	68
2.5.1	Divided noun combinations	69
2.5.2	Non-divided noun combinations	70
2.6	Conclusions	72
3	The Structure of Semantic Agreement	73
3.1	Semantic Agreement	73
3.2	Semantic agreement in British English	75
3.2.1	Singular versus plural agreement with CNPs	76
3.2.2	Part 1: Where plural agreement is (dis)allowed	78
3.2.3	Part 2: <i>i</i> Fs are targeted differently than <i>u</i> Fs	83
3.3	Excursus: The mechanism of Agree	86
3.3.1	Directionality of Agree: A brief overview	87
3.3.2	Accounting for Semantic versus Morphological Agreement	91
3.4	Back to semantic agreement with CNPs	97
3.4.1	Why LF-visibility holds	97
3.4.2	Part 3: Comparison with other theories	100
3.5	Aside: On the movement of features within DP	106
3.6	Semantic agreement in Russian	109
3.6.1	Agreement in Russian: Looking everywhere	109
3.6.2	QNP <i>s</i> in Russian	111
3.6.3	The optionality of <i>i</i> F agreement, and why Russian might pose a problem	114
3.6.4	Russian does conform to LF-visibility	116
3.6.5	Interim Summary	127
3.7	Further support for the analysis: Conjunct Agreement	128
3.7.1	Conjunct Agreement in English	128
3.7.2	A further possible extension: Hindi	132
3.8	Conclusions	133
4	The Agreement Hierarchy	137
4.1	The typology of morphological versus semantic agreement	137
4.1.1	The Agreement Hierarchy	137
4.1.2	Lexical variation, and what is able to show semantic agreement	140
4.2	3/4 patterns	143

4.2.1	Hierarchy based 3/4s	144
4.2.2	Non-hierarchy based 3/4	147
4.3	Multiple grammars, multiple dialects	149
4.4	Smith (2013): Valuation Economy	152
4.5	The origins of <i>Valuation Economy</i>	154
4.5.1	Why anaphor \prec verb \prec adjective?	156
4.5.2	The shifting condition	160
4.5.3	Interim summary	162
4.5.4	British English	162
4.5.5	Russian	165
4.5.6	Hebrew	169
4.5.7	Hebrew double adjectives	170
4.6	Conclusions	182
5	Conclusions	185
	Bibliography	188

Chapter 1

Towards a theory of split features

This dissertation investigates the nature of grammatical features. The main proposal will be that features are not in themselves indivisible units that are the fundamental units of the syntax, but rather features themselves are internally complex. The idea in brief is that each feature that is used in the grammar itself consists of two halves, a half that is interpreted by the morphological component, and a half that is interpreted by the semantic component. Each of these feature halves can have a value relevant to the type of feature it is, but there is no requirement that these values match. In the general case they do match, however we see as we progress that there are various instances where the two halves of a feature take separate values, leading to a mismatch in the morphosyntactic and semantic behavior of a noun. Furthermore, there is no requirement that each half of a feature receives a value in itself. A number feature for instance can have a morphological value, without there being any semantic value of that feature, even one that mismatches.

So, features can match, mismatch, or some values can be missing altogether. From this simple conclusion, we will see that recognizing that features are made up in this way allows us to take a new look at various phenomena in a new light. In the remainder of this section, I will show motivations for such a view of features from a range of mismatch phenomena that show that features must be viewed in this light. Such phenomena include grammatical gender (Corbett 1991, Wechsler & Zlatić 2003), imposters (Collins & Postal 2012) and unagreement (Höhn 2012).

In chapter 2, I will show that the proposal advanced here has various consequences for the mass/count distinction. Firstly, I will show that it offers a novel and interesting analysis of two classes of atypical mass nouns which will be shown to be problematic for current theories of the mass/count distinction, showing as they do variable behavior between mass and count nouns. The first class are fake-mass nouns in English, and I will show that they have the morphosyntactic behavior of being mass nouns, whilst showing count semantics.

I will then consider plural mass nouns in Telugu, which, as I will show, have the morphosyntactic behavior of being count nouns, but they show classic mass semantics, the converse situation to fake mass nouns.

In chapter 3, I show that agreement which usually targets the morphosyntactic features of a noun can also, in some instances, target the semantic features of a noun. Interestingly, this Semantic Agreement will be shown to be possible under different structural conditions than regular morphosyntactic agreement, as will be shown by studying in depth the agreement properties of collective nouns (CNPs) in English and quantified nouns phrases (QNPs) in Russian.

In chapter 4 I will consider the Agreement Hierarchy of Corbett (1979), and where morphological and semantic agreement interact. The main focus of the chapter will be where a noun that has a split between the iF and uF value of a given feature controls both semantic and morphological agreement on two distinct targets. In such configurations, we expect four outcomes for agreement, matching uF agreement across targets, matching iF agreement across targets, and two mismatches. However, quite often, only three of these sentences are grammatical, with one of the mismatch sentences grammatical, but one mismatch sentence ungrammatical. Thus, the problem will be to explain why mismatches between semantic and morphological agreement are generally tolerated, but only in one way. Further confusion is added because whether a mismatch is allowed or not patterns exactly as to what one would expect if Corbett's Agreement Hierarchy were a sentence level constraint. However, given that it is a corpus-level generalization, it is surprising to see the observed patterns. I will show that the illicit mismatches are ruled out independently from the hierarchy, by considering the timing of agreements.

1.1 Mismatches between morphology and semantics

In this section, I outline instances whereby a noun shows a mismatch between its morphological shape and its semantics.

1.1.1 Grammatical Gender

Grammatical gender systems are a famous place where the semantics of a noun does not match its morphological shape. As is well known, certain languages categorize nouns into distinct classes. These classes are more or less arbitrary, but often do have some internal semantic coherence. Systems of grammatical gender are well attested cross-linguistically. German, for instance, categorizes nouns into masculine, feminine and neuter classes. Whilst these classes primarily are distinguished through the morphological behavior of the nouns, there is a strong tendency for nouns that have masculine sex to line up with

masculine gender, and feminine sex nouns to line up with feminine gender. This is not always the case however. For instance, the noun *Mädchen* ‘little girl’ is grammatically neuter, yet its referent clearly notionally feminine.

Interestingly, such classes are not restricted to being formed by ‘gender’ features based on sex, but languages can choose other methods of categorizing. Harbour (2007) shows that Kiowa and Jemez (both Kiowa-Tanoan languages) form classes based on number.

1.1.2 Imposters

Collins & Postal (2012) introduce the term Imposter constructions. Imposter constructions are essentially noun phrases which mismatch the morphological value of person from the semantic value of person. They are defined by Collins & Postal as follows:

- (1) An imposter is a notionally X person DP that is grammatically Y person, $X \neq Y$

Collins & Postal (2012) note that ‘person’ is not a necessary part of their definition of imposters, but merely is there since their study focuses on Imposters that are person-imposters. They say that “there could be gender imposters, number imposters, or seemingly even more arcane types” (Collins & Postal 2012:5). Restricting attention to the person imposters that they are interested in, examples are as follows:

- (2) a. This reporter is/*am signing off from Madrid, Spain.
b. Is/*are Madam not feeling well today?
c. Yours Truly has volunteered herself/*myself for the position.
d. Would the colonel like to open the mail himself/*yourself?

In all the examples in (2), we see that the DP that controls agreement consistently controls third singular agreement, however, the semantics of the noun differ from this (what we would expect is noted with the ungrammatical options). In (2a) and (2c), the referents of the noun are the speaker, and so we would expect first singular forms. Likewise in (2b) and (2d), we again find 3rd singular forms where we would expect 2nd singular forms, since the referents of the noun are the addressee. Thus, we see that the form of the noun mismatches with its interpretation.

It is tempting to view this thesis as a study into Imposters at the featural level. I however refrain from putting it into that context. Collins & Postal set out to explain the phenomenon of Imposter DPs in strictly syntactic terms, positing that all Imposters are complex DPs, where the Imposter DP (i.e. the DP that is morphologically realized) contains a covert pronominal DP, which adds the semantics of the noun. They term this approach ‘The Syntactic View’ of Imposters.

In the approach to features that I will advocate for here, there are no specific syntactic mechanisms that are needed to be appealed to in order to account for why a noun takes one morphological shape but another semantic shape; all that is needed to be said is that the relevant feature diverges in what value is given to the semantic half and the morphological half. This is not to say that certain constructions do not require the more complicated syntax that Collins & Postal argue for; that question is distinct from the claim that features are made up of (potentially diverging) morphological and semantic halves. All I intend to make a claim about is that features are formed in such a way that the morphology and semantics can diverge, and explore what such divergences tell us about the nature of various components of the grammar.

1.1.3 Unagreement

Another example of mismatches between semantic and morphological shape comes from Unagreement constructions in Greek, with the data coming from Höhn (2012).

- (3) (Oi odigoï) de tha pioume (oi odigoï) [Höhn 2012:6]
 DET.NOM.PL drivers NEG FUT drink.1PL
 ‘We drivers won’t drink’ (lit: the drivers won’t drink)

In (3), we see that the agreement on the verb is 1.PL, even though the controller of agreement is 3.PL. The mismatch that we can see is between the semantic person specification of the noun phrase *oi odigoï* and its morphological shape. Importantly here, we are not just relying on the interpretation to see that *oi odigoï* is semantically 1st person, but rather the presence of this feature on the noun is highlighted by the agreement on the verb. Unagreement constructions appear to be similar to the Imposter constructions discussed above, save for the fact that the agreement in (3) is 1.PL, as opposed to the 3.SG/3.PL more familiar from the examples in Collins & Postal (2012).

1.2 Features that match, and ones that do not

1.2.1 A minimalist approach to feature mismatches

The idea of feature mismatches is not novel here. Wechsler & Zlatic (2000) formulate a theory within Head Driven Phrase Structure Grammar (Pollard & Sag 1994) where the semantics and morphology of an item do not line up. In their approach, CONCORD features most closely line up with the morphology and INDEX features line up closer to the semantics. Matching constraints usually ensure that the values of these features line up, but there is no necessity, and the link between the two can be broken.

This dissertation follows very much in the spirit of Wechsler & Zlatić’s approach, but differs in the overall framework which it is couched in. I adopt a Minimalist framework of Chomsky (1995, *et seq.*). Features are considered the driving force behind operations in a minimalist approach in various different ways (see for instance Chomsky 1995, 2000, 2001, Epstein & Seely 1999, Bošković 2007). Thus, the nature of features is a crucial question in the theory of generative grammar. Furthermore, in chapters 3 and 4, we will be considering the operation of AGREE (Chomsky 2000, 2001), and how that accesses *i*Fs, as well as the interaction between *i*Fs and *u*Fs. AGREE is a central operation of the theory now, standing alongside other processes MERGE as one of an ever decreasing arsenal of syntactic operations. How AGREE ought to be defined is another central question in current Minimalist Research, with there being much controversy over a couple of issues. Firstly, whether AGREE should be considered an operation that can look only downwards (Chomsky 2000, 2001, Preminger 2011, 2015), can only look upwards (Wurmbrand 2012a, 2014b, Zeijlstra 2012), or can look either way (Baker 2008). This dissertation will adopt the final view, that the operation of AGREE can look both upwards and downwards in the structure, though differ from existing proposals adopting this view. The second issue concerning AGREE, is whether it is a simplex, one-step operation (Chomsky 2000 among many others), or is complex and split into distinct processes (see among others Benmamoun et al. 2009, Arregi & Nevins 2012, Bhatt & Walkow 2013). I will also argue for the latter position in this dissertation.

Whilst much work in the Minimalist Program accepts that not all features are equal, and distinguishes between *uninterpretable features* and *interpretable features*, there is no clear consensus over what the appropriate definition ought to be. Chomsky (2000, 2001) correlated interpretability as having a value, so that uninterpretable features lacked a value, and interpretable features have a value. However, Pesetsky & Torrego (2007) propose that it is not a bidirectional relationship between interpretability and having a value. Interpretable features could lack a value and uninterpretable features could have a value (see also Bošković 2011, Wurmbrand 2014a among others).

In this dissertation I will take a somewhat pared down approach and only focus on the legibility of features to each grammatical component. Adopting the inverted T-model of the derivation in Bobaljik (1995, 2002), I will therefore assume that the minimal necessary approach to the nature of features is that there needs to be features for the morphology to interpret and features for the semantics to interpret, and that the syntax makes use of only these features.¹ A single phi-feature is then made up of two halves, one half that gets

¹For those curious where phonological features come into play, I will adopt Distributed Morphology (Halle & Marantz 1993), whereby morphosyntactic features are replaced by phonological features during the process of Vocabulary Insertion. Thus, these features are not present in the syntax, but are introduced in the morphological component.

interpreted by the semantics, the *i*F and one half that gets interpreted by the morphology, the *u*F. In the usual case, when the values match up, I simply assume that the feature is represented as follows (taking number as an example):

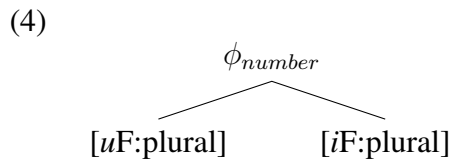

Features can also differ in that the two values diverge. I argue that they take the following structure:

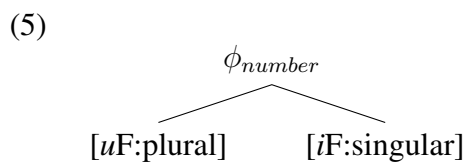

Finally, one value can be missing altogether:

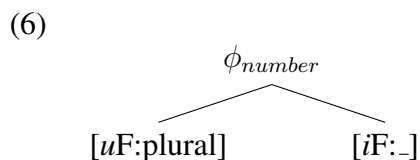

1.3 Overview of the Dissertation

In this introductory chapter I have given the basics of my approach to features, which I will defend throughout the rest of this work. In particular, I will focus on various consequences of viewing features in this manner. The consequences will be noted in various ways.

CHAPTER 2: In chapter 2, I explore the mass/count distinction, in particular I will focus on instances of nouns that appear to be either mass or count in terms of their morphosyntax, but their semantics shows the opposite value. For instance, I will show that this is the case for so called ‘fake-mass’ nouns in English. These are nouns like *furniture*, whereby they are clearly mass nouns in terms of their morphosyntax, since they do not inflect for plural morphology (7), do not combine with numerals (8a) and need a measure phrase to do so (8b), and they combine with the quantifiers *much* and *little*, as opposed to the count quantifiers *many* and *few*, (9):

- (7) * There are furnitures/mails/luggages left to be delivered.

- (8) a. * I brought three furniture(s)/mail(s)/luggage(s).
 b. I brought three *pieces of* furniture/mail/luggage.
- (9) a. There isn't *many/much furniture/mail/luggage left to be delivered.
 b. There is *few/little furniture/mail/luggage left.

However, despite the fact that these nouns seem to be unambiguously mass nouns, they also appear to be interpreted like count nouns rather than mass (Barner & Snedeker 2005, Bale & Barner 2009). As a short illustration, consider the following comparison sentences. Count nouns, as shown in (10a) are compared by number; the sentence is true if the total number of books is greater than the number that I bought. Mass nouns on the other hand are compared by volume; in (10b), the sentence is true if the volume of water drunk by John exceeds the volume of water that I drank. Volume can be measured in various ways with the appropriate choice depending on the noun and situation. Thus, the appropriate comparison could be litres for water, scoops for mud or blocks for ice. Fake mass nouns are only able to be compared in one way, by number, which makes them pattern with count nouns:

- | | | |
|---------|-------------------------------------|-----------------------------|
| (10) a. | John bought more books than me. | <i>Comparison by number</i> |
| b. | John drank more water than me. | <i>Comparison by volume</i> |
| c. | John bought more furniture than me. | <i>Comparison by number</i> |

I will argue in chapter 2 that these nouns have a mismatch in their number feature, which makes them look as though they are mass nouns, when in actual fact, they are count.

In the rest of the chapter, I show that the opposite situation arises in Telugu; there are nouns that have the morphosyntactic properties of being count nouns when they are in fact mass nouns. For instance, the Telugu word for 'water' *niiLLu* will be shown to have plural inflection, and combine with the count quantifier *konni*, but not the mass quantifier *končam*, as shown in (11) versus (12) below. These nouns will be shown to cause a theoretical problem for approaches that claim the mass/count distinction is created syntactically (Borer 2005, Bale & Barner 2009, de Belder 2013), whereby the combination of a count quantifier with a semantically mass noun is not predicted. I propose that mass versus count quantifiers is actually an instance of quantifier allomorphy, conditioned by the *uF:number* feature on nouns:

- (11) aa abbaaji konni nii-LLu taag-ees-tun-aa-Du
 the boy few water-PL drink-EMPH-PROG-PRES-3.MASC.PL
 'The boy is drinking some water.'

- (12) * končam nii-LLu
 little water-PL
 INTENDED: ‘Little water.’

In the remainder of the chapter I discuss the implications of treating mass versus count quantifiers as a case of allomorphy, using data from plural mass nouns in English, and data from Purépecha (Maldonado 2012).

CHAPTER 3: In chapter 3, I discuss how the split between *i*Fs and *u*Fs is manifested in agreement, and what we can learn from this about the mechanism of AGREE (Chomsky 2000, 2001). The discussion in this chapter will focus on where we can tell the difference between semantically motivated agreement (modeled here as agreement with the *i*F of the controller) and morphologically motivated agreement (agreement with the *u*F of the controller).

There will be two case studies of *i*F agreement. Firstly, I will investigate plural agreement with singular collective nouns like *government*, *committee*, which is possible in certain dialects of English:

- (13) a. The government **is** trying to counter the domestic threat from ISIS.
 b. %The government **are** trying to counter the domestic threat from ISIS.²

I will show that although it is generally the case that agreement is free in these cases to alternate between singular and plural (there is a corpus wide preference for singular agreement in general, Levin 2001), plural agreement is systematically more restricted than singular agreement. By this, I mean that the environments where plural agreement is licensed by these nouns is a subset of the environments where singular agreement is possible, as can be seen in the following:

- (14) a. There is a committee deciding the budget for next year.
 b. *There are a committee deciding the budget for next year.
- (15) a. A northern team is likely to be in the final. ∃ >> likely / likely >> ∃
 b. A northern team are likely to be in the final. ∃ >> likely / *likely >> ∃

In explaining these facts, I will argue that the restrictions on plural agreement do not come from lexical differences between plural agreeing and singular agreeing collective nouns, as has been claimed by den Dikken (2001) and Sauerland (2004a,b), but rather it is a difference between semantic and morphological agreement. Plural agreement is

²As will be discussed, the % sign indicates dialectal variability, not any loss in grammaticality.

semantic agreement, which targets the *iF* of the collective noun, whereas morphological agreement targets the singular *uF*. I will argue that semantic agreement is restricted in such a way that it can only happen within the syntax, and only in an upward Reverse Agree fashion (Zeijlstra 2012, Wurmbrand 2012a). *uF* agreement on the other hand is able to be distributed across two domains, both within the syntax and post-syntactically in the PF component.

Also in this chapter I will generalize the approach to facts from Russian QNPs, which have been argued (Glushan 2013) to also show *iF* agreement. I will show again that *iF* agreement is possible in a more restricted manner than *uF* agreement in Russian, and offer an analysis of the facts in Glushan (2013) which is in line with what I propose for the British English data.

CHAPTER 4: In Chapter 4, I provide an analysis of the Agreement Hierarchy in Corbett (1979, 1983, 2000, 2012). Corbett proposes that there is a hierarchy of agreement targets that ranks the likelihood of elements to show semantic or morphological agreement, as shown in (16) below. Elements to the right on the hierarchy are more likely than elements on the left to show semantic agreement. Similarly, elements to the left are more likely to show morphological agreement than elements on the right. Corbett also shows that the hierarchy can be used as a predictive tool: if in a language a certain position on the hierarchy is able to show semantic agreement, so are all elements to its right, but not necessarily its left. If an element shows morphological agreement, then so will all elements to its left, though not necessarily its right. Thus, the hierarchy has been used as a typological generalization concerning likelihood of different types of agreement.

- (16) attributive — predicate — relative pronoun — personal pronoun
 ←-- morphological agreement semantic agreement --→

Our concern in chapter 4 will be instances where the hierarchy appears to play a restricting role within the grammar, by appearing to hold at a sentential level, rather than the corpus level description that it is. The discussion will look at situations where there are two targets of agreement that agree with a controller that can potentially control *uF* and *iF* agreement. This predicts four logically possible combinations of agreement (matching *uF*, matching *iF* and two mismatches). However, what is often the case is that only three of the four combinations are available. In British English, for instance, we find the following 3/4 paradigm:

- (17) a. The government has offered itself up for criticism (with this policy).
 b. The government have offered themselves/each other up for criticism.
 c. The government has offered [?]themselves/each other up for criticism.

- d. *The government have offered itself up for criticism.

It is curious in itself why mismatches between agreement targets should be tolerated, but only in one way. However, even more curiously, the unattested pattern is exactly the one that we'd expect to be ruled out if the Agreement Hierarchy were operative in a single sentence. That is, a sentence where the element to the right on the hierarchy (the anaphor) shows morphological agreement, but the element on the left of the hierarchy (the auxiliary) is licit, but the converse is not. This may seem to be an accident, but the same situation happens in Russian (Corbett 1983), showing the British English data to not be an isolated incident:

- (18) a. Novyj vrač skazal.
 new.MASC doctor said.MASC
 'The new doctor said.'
- b. Novaja vrač skazala.
 new.FEM doctor said.FEM
 'The new doctor said.'
- c. Novyj vrač skazala.
 new.MASC doctor said.FEM
 'The new doctor said.'
- d. * Novaja vrač skazal.
 new.FEM doctor said.MASC
 'The new doctor said.'

Even more interestingly is that *uF-iF* mismatches are restricted not just by hierarchy effects, but other factors, such as in the following from Chichewa (Corbett 1991):

- (19) a. ngwazi y-athu y-oyamba
 hero 9-our 9-first
 'Our first hero.'
- b. ngwazi w-athu w-oyamba
 hero 1-our 1-first
 'Our first hero.'
- c. ngwazi y-athu w-oyamba
 hero 9-our 1-first
 'Our first hero.'
- d. *ngwazi w-athu y-oyamba
 hero 1-our 9-first
 INTENDED: 'Our first hero.'

I will argue that the hierarchy effects seen in English, Russian and Chichewa arise from different sources. Which mismatches are allowed and which are not will be shown to follow from the order in which elements merge into the structure. I will show that *i*Fs can enter the derivation as active or inactive. If they are deactivated throughout the derivation, then agreement can switch from semantically motivated to morphologically motivated agreement. However, it is not possible for an inactive feature to become active, thus, a switch from morphologically motivated agreement to semantically motivated agreement is not possible. Coupling this with the order in which elements are merged into the structure allows us to understand sentence internal Agreement Hierarchy effects, without appealing to either extrinsic ordering or hierarchies.

Chapter 2

Atypical mass nouns

2.1 Introduction

In this chapter, I will look at the mass/count distinction from the perspective of split features. I will show that treating features in such a manner has interesting implications for the study of mass versus count, and in particular, nouns that seem to fall some way in between the two categories. As a preview to the conclusion of the chapter, I will show that there are nouns in English that we can identify as having the semantic properties of being count nouns, but the morphosyntax of mass nouns. Conversely, in Telugu, I will show that the nouns *niiLLu* and *paalu* have the semantic characteristics of mass nouns but the morphosyntax of count nouns. In short, we find the following typology of mass and count:

(20)

	Semantic Properties		
	+Count	Regular count noun	+Mass
Morphosyntax	+Count	Regular count noun	<i>niiLLu</i> and <i>paalu</i>
	+Mass	Fake mass nouns	Regular mass noun

2.1.1 Mass versus count: A general overview

The mass/count distinction is at its heart about the dichotomy between nouns that can be counted, and those that resist counting. It is very much an open question whether all languages have a mass/count distinction, however, in some languages the differences between the two nouns are quite striking. For instance, in English, count nouns differ from mass nouns in a number of ways. The first, extremely salient difference between the two categories is that count nouns like *owls* can directly combine with numerals, whereas mass

nouns like *water* are not able to. Instead, they must combine with some kind of measure phrase, which in turn combines with the numeral.

- (21) a. There are three owls on the branch.
 b. *There are three waters on the floor.
 c. There are three *drops of* water on the floor.

Secondly, count nouns differ from mass nouns in their ability to combine with number morphology. In English, count nouns are able to combine with plural morphology, however mass nouns cannot:¹

- (22) a. There are crumbs on the floor.
 b. *There is waters on the floor.

Thirdly, count and mass sometimes differ with respect to which quantifiers they combine with. In English, this is reflected in differences with combination with *many* versus *much*, and *few* versus *little*. Count nouns, but not mass nouns combine with *many* and *few*, whereas mass nouns, but not count nouns combine with *much* and *little*:

- (23) a. There are many/*much ducks in the pond.
 b. There is *many/much sand left to be moved.
 c. There are few/*little questions left to answer.
 d. There is *few/little water left to drink.

It should be noted that having quantifiers that are apparently selective for mass versus count is not a prerequisite for there being a mass/count distinction in some language. Dutch, for instance uses the same quantifier *veel* ‘many/much’ to cover both mass nouns and count nouns, thus the distinction between *many* and *much* is neutralized:

- (24) Ik heb veel boeken/water gekocht.
 I have many/much books/water bought
 ‘I bought many books/much water.’

Despite there being no difference in the quantifier, there is still a mass/count distinction in Dutch, since *boeken* ‘books’ can combine with numerals, but *water* ‘water’ cannot:

¹(22b) is actually grammatical, however only on a reading where *water* has been shifted to a count reading. I’ll return to this point later. As with the quantifier difference below, this is only a potential difference between mass and count nouns. Some languages have mass nouns which do combine with plural morphology, though what that plurality signifies varies from language to language. For a discussion of this, I refer the reader to section 2.3.2.1, and in particular section 2.3.2.2 below.

- (25) a. Ik heb drie boeken gekocht.
 I have three books bought
 'I bought three books.'
- b. *Ik heb drie waters gekocht.
 I have three waters bought
 INTENDED: 'I bought three waters.'

These are the main morphosyntactic characteristics of the mass/count distinction. There are surprisingly few languages which mark the distinction morphemically. However, Asturian dialects of Spanish do appear to morphologize count versus mass (Hualde 1992):

- (26) a. pílu 'hair (count singular)
 b. pélo 'hair' (mass)
 c. pélos hair (count plural)

Semantically, there are also differences between mass nouns and count nouns. Perhaps the most salient difference between mass nouns and count nouns, one easily reflected by intuition is that the denotation of count nouns consists of a collection of discrete entities, but the denotation of mass nouns does not, see for instance Link (1983).² Count nouns can be counted because one has access to individuals which can serve as the basis for counting, whereas mass nouns lack such individuals, and hence one cannot meaningfully count them.

Aside from simply counting or not counting, the lack of individual entities in mass nouns can be seen in different ways. One way shown by Bale & Barner (2009) (see also Barner & Snedeker 2005) is through comparison. In a sentence of the form *John has more X than Mary*, if a count noun takes the place of X, then the standard of comparison is number of instances of the noun. So, the following is true if the number of ducks than John has is greater than the number that Mary has:

- (27) John has more ducks than Mary.

Relevant is that the size or weight or any other information about the ducks, is not important for the purposes of comparison. With a mass noun however, these measures are what is used for comparison, no longer number of individuals. Thus, in the following, the overall quantity of water is what is important, irrespective of the number of individual portions John and Mary have:

- (28) John has more water than Mary.

²As we will get to below, there is controversy over this point.

This contrast between mass and count nouns is easily explainable if the denotation of a count noun is composed of individuals but the denotation of a mass noun is not.

Another contrast along the same lines is found with stubbornly distributive predicates, as shown in Schwarzschild (2011). Schwarzschild shows that certain predicates like *large* can only be true of individual entities. So, in a sentence like *the boxes are large*, then what is large are the individual boxes, and not the collection of boxes. So, the sentence could not be truthfully uttered to describe a large pile of small boxes. Predicates such as *large* are not compatible with mass nouns, hence *#the water is large*. Again, supposing that the difference between mass nouns and count nouns is such that the denotation of the latter includes individuals but the former not, then it makes sense that predicates that refer exclusively to individuals can only combine with count nouns.

2.1.2 Mass versus count

Various proposals have attempted to explain the mass/count distinction as mass nouns and count nouns being fundamentally different. Here I briefly discuss some of the attempts, however the literature is too large to give a full overview here.

2.1.2.1 Lattice-theoretic mass versus count

The mass/count distinction is often explained in terms of individuated denotations for count nouns, and non-individuated ones for mass nouns. Link (1983) for instance proposes that the distinction is exactly manifested in this way. The denotations of nouns can be modeled in terms of semi-lattices. Lattices represent individuals and the groups that they form. For example, a noun like *the boys*, where there are three boys, consists of the individual boys, the ‘atoms’ *a*, *b* and *c*, and the groups that can be formed of these *ab*, *bc*, *ac* and *abc*. This is represented on a lattice structure in the following way:

(29)

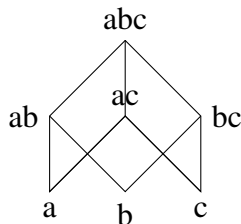

In such lattices, we can see the relationships between all the parts. The ones at the bottom, *a*, *b* and *c* are the minimal parts of the noun, and the groups are *ab*, *bc*, *ac*, and *abc*. Bale & Barner (2009) note that lattices can come in various types, but the ones that I

will restrict attention to are individuated lattices, like in (29). Individuated lattices are ones where the members at the bottom of the lattice are individuals, defined in the following way (Bale & Barner 2009:237):

- (30) Definition of ‘individual’: an aggregate z is an individual for a set of aggregates X iff z is a minimal part for X and for all aggregates $y \leq X$, either (i) $z \leq y$ or (ii) there is no $w \leq z$, such that $w \leq y$.

Importantly, these lattices make minimal parts available to the grammar for operations that require them. I assume that distributive operations, as well as counting both require access to these minimal parts. Count nouns will have the interpretation in (29).

The other type of lattice that will be relevant to us will be what Bale & Barner (2009) call *continuous semi-lattices*. The crucial aspect of these lattices is that there are no minimal parts; at no point in the lattice can one define an element that is not itself made up of other elements. They are essentially groups all the way down, and at no point do they make minimal parts available to the operations of the grammar that needs them. These lattices I will assume are the interpretation of mass nouns. In this regard, I am following the approach of Link (1983) who made this exact cut between mass nouns and count nouns. Doetjes (1997) shows that adopting these lattices for the differing interpretations of mass versus count nouns allows us to account for the fact that both count plurals and mass nouns have cumulative reference: if x and y are the same predicate, and they are added together, then they still satisfy that predicate. For instance, if x is a set of ducks and y is a set of ducks, then $x+y$ is a set of ducks. Similarly, if x is water and y is water, then $x+y$ is water. Mass and count nouns differ in what is known as atomic reference; put simply, if a predicate is atomic, then there is a proper subpart of that predicate that is a minimal part. In *the ducks*, we can define a minimal instance of a duck, but not so with *the water*. The exact semantic definitions of these are not directly relevant to the issue at hand, and so I refer the reader to Krifka (1992) and Doetjes (1997) for further reference.

Note, that I differ from Chierchia (1998, 2010), who assumes that all lattices are individuated, but that with mass nouns the minimal parts are vaguely defined. Other semantic approaches to the mass/count distinction have been offered by various people, including Landman (1989a,b), Gillon (1992), Rothstein (2010), among many others.

2.1.2.2 Flexible roots: Mass and Count defined syntactically

Much research into the mass/count distinction has recently centered on the idea that nouns are not inherently specified to be either mass or count, coupled with an additional ability to coerce nouns from one class into the other, but rather that nouns begin life unspecified for being either mass or count, and they are turned either mass or count depending on

the syntactic environment in which they find themselves. Such research is guided by the observation that most nouns, at least in languages like English, can be either mass or count depending on their surrounding context. Consider a noun like *urchin* for instance. In (31) below, *urchin* is easily identifiable as a count noun since it combines with the indefinite article *an*. In (32) however, the absence of an article, coupled with the absence of plural morphology and the presence of the quantifier *much* allows us to identify that *urchin* is being used as a mass noun, and not count.

(31) The crafty sea otter plucked an urchin from the sea floor.

(32) The greedy sea otter ate too much urchin, so needed to sleep.

The fact that this can happen to virtually any noun in English and other languages (though perhaps not Chinese, Cheng et al. 2008) has led to a spate of recent proposals arguing that the mass/count distinction is created syntactically, and that nouns are not inherently mass or count. For instance, a prototypical mass noun like *water* can easily be shifted into a count context:

(33) I bought three waters.

Central to this approach is the notion that nominal roots, without any functional head to create division, denote ‘undivided stuff’. That is, the denotation of the noun *cat* is not the set of individual cats, but rather everything that could plausibly fall under being described as ‘cat’ - cat meat, individual cats and pluralities of cats. Furthermore, the second central tenet of this approach is that this is all that mass nouns constitute - they are undivided denotations: denotations which do not contain atomic entities of the noun in question. Therefore, in (32) above, the mass noun *urchin* denotes something that if divided, will still qualify as *urchin*.

This view, originally proposed by Borer (2005), and modified in Bale & Barner (2009) holds at its core the idea that roots are unspecified for being either mass or count, and that masshood and countness is created by syntactic context.

The idea in brief states that roots at their most basic level denote undivided material and that masshood is just a reflection of this, i.e. that the extension of a mass noun like *sand* is simply an undivided quantity of sand. Being count, by contrast, results from the division of the ‘material’ that the root originally denotes. The division operation creates minimal parts - parts that cannot be divided any further and still truthfully satisfy the predicate. These minimal parts are used as the basis for counting, and make it possible for comparison by number instead of overall volume, since groups of distinct individuals can be created and compared. Borer (2005) and Bale & Barner (2009) differ in details, so I first describe the systems and point out the relevant differences, however it should

be borne in mind that they both exemplify the same school of thought that masshood is simply a reflection of the default meaning of the root.

2.1.2.3 Borer (2005)

Borer (2005) argues in essence that masshood is the absence of countness. Roots, as mentioned, are unspecified for being either mass or count. Where this is created is through the presence or absence of a syntactic functional head that creates division, Cl(assifier)P. CIP takes the undivided material that is denoted by the root, and gives a divided output. Importantly at this point, is that roots are mass to begin with, and the absence of any dividing structure will yield a mass noun:

“...recall that I suggested that listemes do not have any formal properties, and are, in this sense, tantamount to raw material ‘stuff’ which is poured into the structural mould to be assigned grammatical properties. If this metaphor has any formal substance to it, it follows that nouns, by themselves, are stuff, and that stuff, as such, is simply the absence of any grammatical specification. Should this stuff be divided, it would be, so to speak, cast into mould(s) which would in turn make counting possible. In the absence of such moulds, stuff will remain unformed, or differently put, it will revert to a mass interpretation. Importantly, by this logic mass is not a specification, lexical or grammatical, but the absence of one.” Borer (2005:108)

Borer gives the structure of mass nouns as the following:³

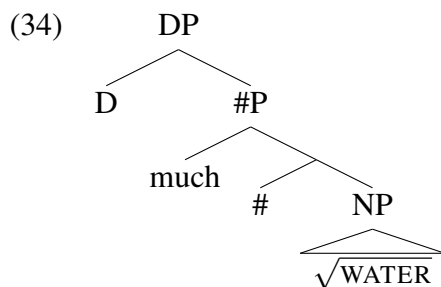

Count nouns are treated differently. Count interpretation, as noted, is obtained through the merging of dividing structure, CIP, into the syntax. In the following, we can see the extra layer of complexity that exists in count nouns:

³In the diagram, *much* is there to highlight the fact that the structure is mass, and does not play any role greater than that here, see also *many* in (35).

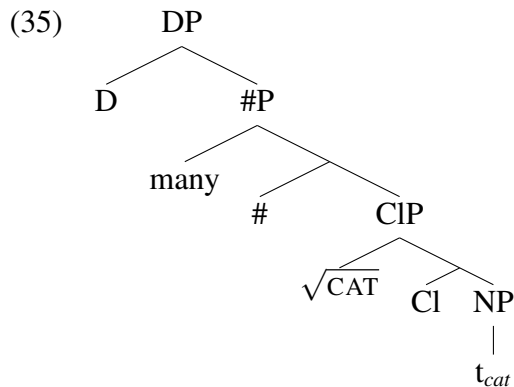

In the tree, $\sqrt{\text{CAT}}$ moves up to Spec,CIP. Borer proposes that this is the case in languages like English, where count nouns can be distinguished from mass nouns on the basis of being able to bear number morphology. For Borer, plural inflection is the “realization of an abstract feature which assigns range to the open value that heads a classifier phrase.” Crucially in this proposal, plural inflection is only possible when there is a CIP in the tree. Therefore, plural inflection entails being a count noun.⁴

The presence or absence of CIP can be detected in different ways. In English and languages like it, it is spelled out as plural morphology. In languages like Chinese where there is no number morphology, it gets spelled out as a classifier. The argument for treating classifiers as the equivalent of plural morphology is that in languages like Chinese, it is necessary to use a classifier in order to count the noun, whilst in English, plural morphology is necessary. Treating both of these things as the spellout of the Cl allows Borer to have a uniform syntax for different languages as well as explaining why it is overwhelmingly, with few exceptions, the case that classifiers and plural morphology are generally in complementary distribution across languages, and within the same language if a language has both.

2.1.2.4 Bale & Barner (2009)

Bale & Barner (2009) offer a related proposal to capture the mass/count distinction, but do so in a way that masshood is not simply the absence of dividing structure in the phrase. Their approach builds on the idea that masshood is simply the default meaning of a nominal root, and that count interpretation comes about through syntactically created division. This is achieved in a different way to Borer however. Recall that for Borer there is in essence only one bit of functional structure relevant for the mass/count distinction, CIP.

⁴Generally, but not in case a language freely allows mass nouns to combine with plural morphology, as is the case in Halkomelem Salish (Wiltschko 2008) for instance.

Nouns that occur in a syntax without CIP are mass, and nouns that combine with CIP are count. Bale & Barner (2009) propose instead that there are two functional heads, COUNT and MASS that are relevant, with each head contributing a different semantic operation. Thus, the structures that are involved in their approach are as follows, with (36) giving a count noun, and (37) giving a mass noun:

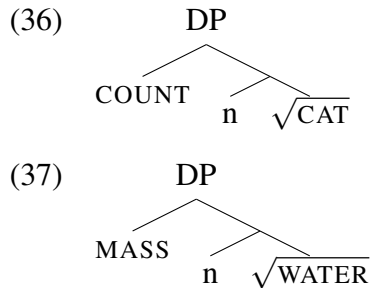

According to Bale & Barner (henceforth B&B), COUNT is the head that is responsible for division. Nominal roots still have mass denotations in the absence of anything to divide them. The COUNT head performs this role, and is a semantic function from unindividuated semilattices into individuated ones (see section 2.1.2.1 above). Thus, the COUNT head, when applied to a nominal root, will always yield an output where the semantic denotation of the noun in question contains minimal, atomic parts. In other words, the reason why count nouns are semantically divided is because COUNT ensures that their denotation will have minimal parts in it. Mass nouns on the other hand do not contain individuated semilattices. Unlike Borer, who proposed that this happens when nothing is done, B&B still argue for the existence of a MASS head. However, MASS is simply an identity function. Thus, the input to MASS is also the output; when an undivided noun root combines with MASS, then the result is still a denotation without minimal parts.

In B&B's system, COUNT is essentially a gateway to count syntax; it creates the minimal parts needed for combination with NumP (where numerals and plural morphology are introduced), as well as serving as the selectional property of quantifiers. Quantifiers that go with count nouns select for COUNT, whilst mass quantifiers select for MASS.

The flexible roots approach, successful at explaining a number of properties that are characteristic of the mass/count distinction, however makes the prediction - correct in the majority of cases - that mass properties and count properties ought not to co-occur on the same noun. The presence of a dividing head in the structure creates division, but is also the gateway to count-syntax. Masshood results from the absence of this head, countness from the presence; nouns should in theory show either one set of properties or the other.

Now, whilst this is true in many cases, there are various instances where mass nouns show apparently 'count' properties. In the remainder of this chapter I will focus on two types of mass noun that seem to exhibit count properties. The first type comes from fake

mass nouns in English, exemplified by nouns such as *furniture*, *mail* and *luggage*, which have all the morphosyntactic properties of being mass, but apparently the semantics of being count. The second type comes from mass nouns that take plural inflection, whilst retaining a mass reading. It is these nouns which I will provide an analysis for, working within the flexible roots approach.

I will broadly adopt the approach of Bale & Barner here, however with one key modification. I will assume that the individuating functional heads MASS and COUNT are distinct ‘flavors’ of n . That is, the dividing and identity functions that Bale & Barner identify are not separate functional heads in their own right, but rather properties of category defining nodes. I will annotate these as n_{+DIV} and n_{-DIV} respectively. The reasons for placing these functions on n will become clearer in section 2.2.4.1. For now, I assume that the structure of count nouns and mass nouns are as follows. Note that the structure of nouns differs only in which type of n is selected:⁵

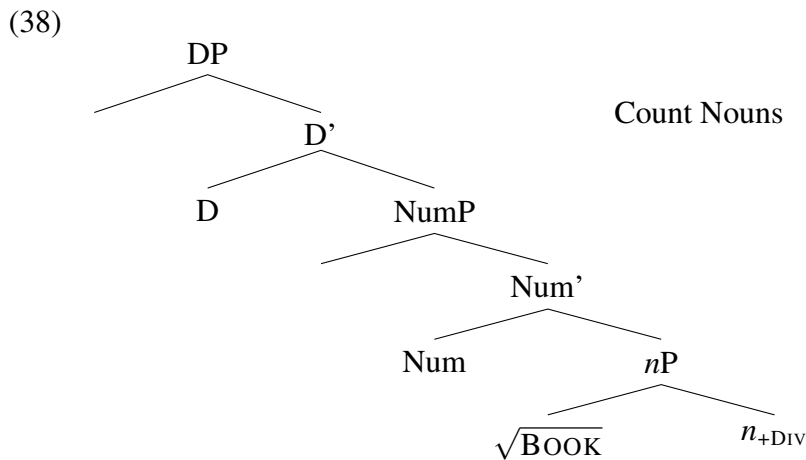

⁵I differ from Borer (2005) in assuming that there is number information potentially in mass nouns. That NumP can project in mass nouns is rare, but does arise in languages that allow for plural mass nouns, such as Greek (Tsoulas 2007) and Halkomelem Salish (Wiltschko 2008), see section 2.3.2.2 for further discussion.

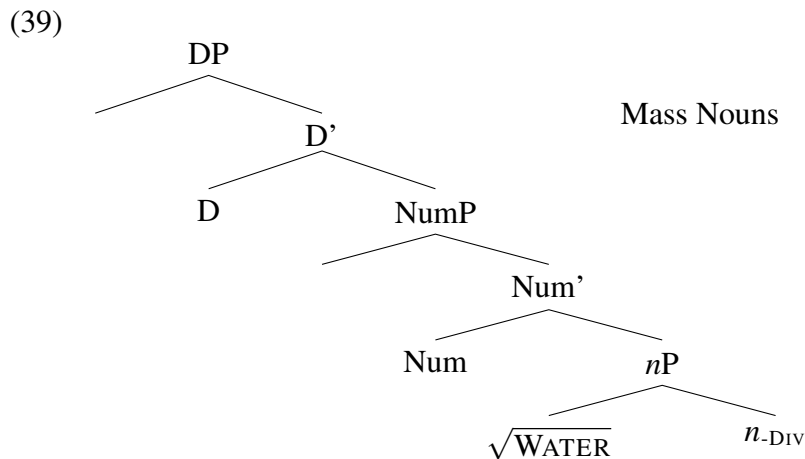

2.2 'Fake' mass nouns in English

The first set of atypical mass nouns are fake mass nouns in English. Recall from above that count nouns in English differ from mass nouns in that they can combine directly with numerals, can combine with plural morphology, and appear with count quantifiers like *many* and *few*, as opposed to *much* and *little*.

There are also differences between the two classes which seem to relate to the way that the two classes of nouns are interpreted. Count nouns have been argued to be interpreted as if they are individuated, in the sense that we have a clear intuition as to what counts as a minimal unit of a count noun. Mass nouns on the other hand have been claimed to lack this interpretation, and be interpreted as unindividuated 'stuff' (Bale & Barner 2009). We saw this earlier with the discussion of stubbornly distributive predicates, and comparison.

2.2.1 Fake-mass nouns are atypical mass nouns

In this section I show that fake-mass nouns, like *furniture*, whilst they seem to be mass nouns since they have the classic surface characteristics of mass nouns, in fact have a semantic interpretation more in line with count nouns as they seem to show a divided individuated interpretation.

2.2.1.1 The morphosyntax of fake mass nouns

Fake-mass nouns seem at first glance to be uncontroversially mass nouns. They do not combine with numerals without the aid of some measure phrase like *piece* or *bit*.

(40) * I brought three furniture(s)/mail(s)/luggage(s).

(41) I brought three *pieces of* furniture/mail/luggage.

Furthermore, as shown in (42), they do not take plural morphology. These nouns are in fact more stubborn than other mass nouns, in that they appear to firmly resist plural morphology in all circumstances. Bale & Barner (2009) show that they cannot shift into a count reading to take plural morphology (43a), as mass nouns in English generally do (43b):

(42) * There are furnitures/mails/luggages left to be delivered.

(43) a. * I bought three furnitures for your new place.

b. I bought three beers for us at the bar.

Finally, fake-mass nouns appear with mass, but not count quantifiers:

(44) a. There isn't *many/much furniture/mail/luggage left to be delivered.

b. There is *few/little furniture/mail/luggage left.

2.2.1.2 The interpretation of fake mass nouns

However, despite the fact that these nouns have all the surface properties of being mass, when looking at the interpretation of these nouns, they seem to be interpreted as if they are individuated. Doetjes (1997) notes that we have an idea of what a minimal part of a noun like *furniture*, *mail* and *luggage* is. She gives the following pair of sentences, which show that a true mass noun like *cheese* can be continuously divided, and still be considered *cheese*, yet the same is not true of a fake-mass noun like *furniture*:

(45) a. A piece of a piece of cheese is a piece of cheese.

b. A piece of a piece of furniture is NOT a piece of furniture.

Schwarzschild (2011) shows that fake-mass nouns do not pattern with true mass nouns in terms of their ability to combine with stubbornly distributive predicates. Recall from the discussion above that these predicates are such that they must obligatorily distribute to individual entities, and cannot be true of an overall collection. Mass nouns do not felicitously combine with these predicates, ostensibly because they are interpreted without the minimal parts necessary for these predicates to distribute. However, as can be seen below, fake-mass nouns quite happily combine with stubbornly distributive predicates, patterning in this respect with count nouns, but crucially not with true mass nouns:

- (46) a. The furniture is large.
 b. The mail is round.
 c. The luggage is small.

Finally, with respect to the semantics, Bale & Barner (2009) show that these nouns are interpreted in comparison contexts in the same way as count nouns, but not in the way that mass nouns are; they are compared by number of entities and not size or volume etc. Therefore, in (47), the sentence is felicitous if it is the case that Chris bought three small barstools and Mark one grand piano, but not vice versa. Therefore, it is the number of individual pieces of furniture that are relevant for comparison, not the overall volume of furniture that was bought, since grand pianos are far larger than barstools.

- (47) Chris bought more furniture than Mark.

2.2.2 How fake mass nouns have been incorporated into the theory of mass versus count

As shown in the subsection above, fake-mass nouns are problematic for giving a uniform theory of what it means to be mass. These nouns show variable properties between being count (individuated) and mass (surface properties), which naturally causes problems for any theory which bases the distinction between count nouns and mass nouns on (lack of) individuation, e.g. Link (1983). In the flexible roots approach, where the mass/count distinction is syntactically created, all roots are underspecified for mass or count and count nouns are created through merger with the root of functional structure that creates individuation. Yet, fake-mass nouns clearly cause a problem for this, because if there is a strict correlation between surface properties and lack of individuation, count-mass nouns are unexplained.

In response to this problem, Bale & Barner (2009) propose that the mass/count distinction is not characterized by the presence or absence of structure, but simply the presence or absence of division. Roots are still taken to be underspecified for being mass or count, but when merged into the structure, they combine with a MASS functional head or a COUNT functional head. COUNT creates division, since the semantic function of the head is that it takes something that is unindividuated (like a root for instance) and its output is individuated. MASS on the other hand is an identity function, and it simply maps the input to the output. Thus, since roots are unindividuated when they combine with MASS, they are unindividuated in the output.

Bale & Barner claim that fake-mass nouns can only combine with MASS, but crucially not COUNT, since they are inherently individuated. This renders them unable to combine with COUNT, since they are already divided and COUNT can only combine with *undivided*

roots. Since fake-mass nouns are individuated as a lexical property, they show the same interpretation as a count noun, even though they have mass structure.

2.2.3 The effect of inherent number

If, as claimed by the approaches of Bale & Barner (see also de Belder 2013), that fake-mass nouns are really underlyingly the same as true mass nouns, differing only in that they have divisibility as an inherent property, then we would expect them to have the same properties as mass nouns with respect to their surface behavior. This, however, is not the case. Bale & Barner note that fake-mass nouns are far more resistant with respect to mass to count shifts than mass nouns. In English, it is fairly easy to make a true mass noun like *water* and *beer* into a count noun, such as in (48a) and (48b) below. However, fake-mass nouns rigidly refuse to undergo such shifts, (48c):

- (48) a. Mike was so thirsty he drank three waters one after another.
 b. Mike drank so many beers at the party, I didn't think he'd see the end.
 c. * Mike didn't know what to do with so many furnitures.

Bale & Barner say that the reason that mass to count shifts are not possible with fake-mass nouns, is simply because they lie outside the domain of the dividing function. Their interpretation is already one of being individuated, and since COUNT is a function from unindividuated structures to individuated ones, then fake-mass nouns are unable to combine with it, and hence are restricted to only appearing with MASS.

The differences however seem to lie deeper than which syntactic head certain roots can combine with. The observation which I wish to note here is that fake-mass nouns appear to share a more local relation with their measure phrases than true mass nouns do. Bhatt (2012) shows that in English, when making comparisons, there are three positions in the sentence that *more* can occupy. *More* can appear between the numeral and the measure phrase (49a), between the measure phrase and the noun (49b) and between the noun and the standard of comparison (49c). These positions are represented schematically in (50):

- (49) a. Mike bought three *more* gallons of oil than Sam.
 b. Mike bought three gallons *more* oil than Sam.
 c. Mike bought three gallons of oil *more* than Sam.

- (50) Mike bought three (❶ more) gallons (❷ more) (of) oil (❸ more) than Sam.

However, when we look at fake-mass nouns, we see that position ❷ is unavailable, and *more* is unable to interrupt between the measure phrase and the noun. The other positions for *more* are fine, as shown:

- (51) a. Mike bought three *more* pieces of furniture than Sam.
 b. * Mike bought three pieces *more* furniture than Sam.
 c. Mike bought three pieces of furniture *more* than Sam.

The fact that position ② is unavailable with fake-mass nouns hints that they may have a different syntax than true mass nouns, since they clearly seem to hold a more local relationship with the measure phrase than true mass nouns do. Interestingly, in this respect, fake-mass nouns behave in much the same way as *pluralia tantum* nouns, which in many dialects of English require the use of a measure phrase in order for them to combine with numerals (52). In comparison contexts, we find again that position ② is unavailable (53):

- (52) Mike packed three *(pairs of) trousers to take on holiday.
 (53) a. Mike bought three *more* pairs of trousers than Sam.
 b. * Mike bought three pairs *more* trousers than Sam.
 c. Mike bought three pairs of trousers *more* than Sam.

As it happens, the similarities between fake-mass nouns and *pluralia tantum* nouns do not stop there. As mentioned above, both fake-mass nouns and *pluralia tantum* nouns require some form of measure phrase in order for them to properly combine with numerals. This is also of course true of true mass nouns; however, an important difference that sets apart true mass nouns from the other two classes is that the measure phrases used for true mass nouns are semantically meaningful, whereas with fake-mass nouns and *pluralia tantum* nouns the measure phrases seem to be semantically vacuous. Fake-mass measure phrases are general terms like *bit*, *piece* and *item*, and, as pointed out in Doetjes (1997), these measure phrases “[...] such as *piece* are so general that we can assume that they give us no clue as to how to make a partitioning.” *Pluralia tantum* measure phrases are items like *pair*, as in *a pair of trousers*, *a pair of scissors*, and *set*, *a set of wheels*. One could of course claim that these are semantically meaningful in that *pluralia tantum* in English can be argued to be usually things that are pairs. For instance, *trousers* have two legs, *glasses* have two lenses, *scissors* have two blades. Yet it is notable that we are not talking about literal pairs here: *scissors* are not made up of two separate scissor components, nor does one trouser plus one trouser make trousers. Therefore, the semantics of *pair* seems to play only a marginal role.⁶

Measure phrases for true mass nouns however do have a genuine semantic import. Measure phrases of true mass nouns contribute information about the size and the shape

⁶One could argue that the semantics is represented, since with English *pluralia tantum*, those nouns which do lend themselves to being composed of two parts do combine with *pair*, such as *scissors* (two blades), *trousers* (two legs), but those nouns do not, go with other measures, like *set*.

of the quantity of the mass noun that is being described. To see that they have a genuine semantic import, there are notable differences between *a splash of milk* and *a drop of milk*. Similarly, there is a true difference between *a mound of sand* and *a grain of sand*. These differences of shape and size are not present with the measure phrases of fake-mass nouns - *a piece of furniture* is the same as *an item of furniture*.

2.2.4 Count-mass nouns are imposters, masquerading as mass nouns

The similarities between fake-mass nouns and *pluralia tantum* seem worthy of being taken seriously, and here I propose that the reason that they act the same way is that these properties are the result of each noun having an inherent number specification. I will show how having an inherent number specification in English prevents a noun from combining with non-inherent number. The result of this is that certain nouns can be made to look like mass nouns, even though they are not really. Throughout this section, I will show that all the properties that make fake-mass nouns look as though they are mass on the surface are misleading. The fact that they cannot combine with numerals without measure phrases, do not take plural morphology and go with apparently mass quantifiers, all arise independently, from the effect of inherent number.

2.2.4.1 Background assumptions

I propose that fake-mass nouns in English are not mass nouns, but rather that they are roots that are inherently individuated, and inherently specified to be semantically plural. That is, they have an individuated interpretation consisting of individuals and groups of individuals. This is in line with Chierchia (1998), who notes the clear similarities between fake mass nouns and plural count nouns.⁷ It is important that they are individuated, since it is with this that they are able to combine with stubbornly distributive predicates and have comparison done by number. Also of note is that the plurality of fake mass nouns is only semantic in nature, since as shown, they never appear with plural morphology nor control plural agreement. In the two-half approach to features, we then say that these nouns combine inherently with [*i*F:plural], which lies on n_{+DIV} .

Following Kihm (2005), Harbour (2007), Acquaviva (2008b), Kramer (2009, 2014), I assume that there is a disconnect between where inherent and non-inherent information is introduced in the structure. Specifically, following Acquaviva (2008b), I will assume that inherent features on nouns are located on *n*, not on the root itself *contra* for instance

⁷Though Chierchia claims that this is the case for all mass nouns. In short, the proposal is that mass and count nouns have the same interpretation in that they are both interpreted with respect to groups and individuals, but with mass nouns (and fake mass nouns, with Chierchia not claiming that they are a different class) the identification of individuals is semantically vague.

Embick & Halle (2005). I postpone further discussion of this point until the end of this subsection, but it is important to note that in what I propose there is no correlation between interpretability and inherence; inherent features can be either *u*Fs or *i*Fs, in the same way that non-inherent features can be either *u*Fs or *i*Fs.

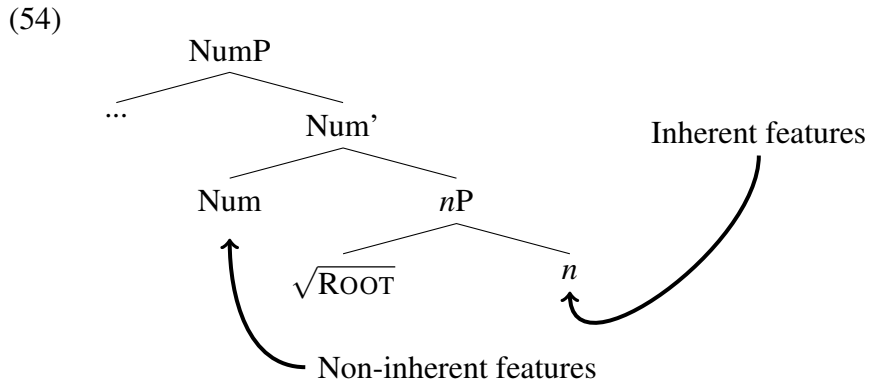

I will further assume that the flexible roots approach is broadly correct, that roots are, in the usual case, unspecified for being either mass or count, and that this distinction is created in the syntax. I further assume a version of the flexible roots approach that Bale & Barner (2009) advance, that the difference between mass nouns and count nouns comes from there being different MASS and COUNT heads. COUNT is semantically interpreted as a dividing function, with the output of the operation being an individuated semi-lattice. MASS on the other hand is an identity function, which maps something to itself. There are however, two important modifications that I make to this approach. Firstly, I assume that these are not separate heads in the structure, but in fact different flavors of *n*; the dividing or identity functions are located on the category defining node. I annotate this as n_{+DIV} and n_{-DIV} respectively.

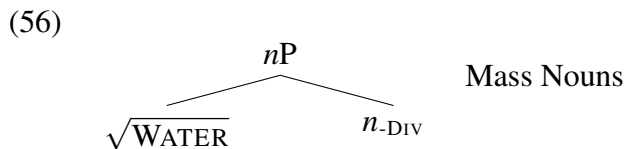
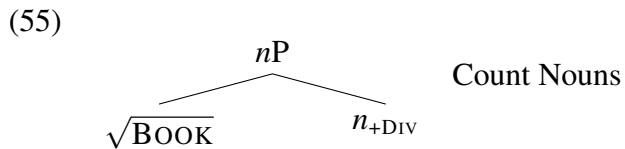

The second modification to Bale & Barner's approach that I will make is that the

distinction between mass versus count quantifiers is not related to the n_{+DIV} and n_{-DIV} . Bale & Barner propose that the quantifier difference is related to MASS and COUNT, in that count quantifiers surface when they combine with a structure containing COUNT. Mass quantifiers on the other hand arise when they combine with a structure containing MASS. For reasons that will become apparent below, I move away from this proposal, and argue that the relevant factor is morphological number.

Before discussing how mass versus count quantifier differences arise, I make one further proposal regarding fake mass nouns. I propose that they are inherently divided *and* inherently plural. That fake mass nouns are inherently divided is not a novel assumption; Bale & Barner (2009) make the same assumption and it is this that allows them to explain why it is they behave in the way that they do. I however make the additional assumption that they are plural, that is they always carry the feature [*iF:plural*]. This means that, unless modified by a measure phrase, fake mass nouns will always be interpreted as plural entities, that is, they are essentially collections. I depart from Bale & Barner in one crucial respect however: I assume that fake mass nouns necessarily combine with n_{+DIV} , and the [*iF:plural*] value is located on n_{+DIV} . For Bale & Barner, fake mass nouns necessarily combine with the functional head that creates mass nouns, whereas for me, they necessarily combine with the functional head that creates count nouns.

This is, admittedly, a rather large divergence from Bale & Barner, and so it warrants further discussion. Firstly, the two accounts differ in how fake mass nouns come to show the properties of being divided. For Bale & Barner, there are two ways through which nouns can become divided; either a regular root combines with COUNT, or the root itself is already divided (which then further precludes the root from combining with COUNT). Fake mass nouns come to be divided through the latter option. I propose here that there is only one method of division: in order to become divided, roots must combine with n_{+DIV} . Therefore, in order for a root to be inherently divided, it must be the case that the grammar restricts the root as such that it can only combine with n_{+DIV} , as detailed above. As will be discussed in section 2.2.5, the major reason why Bale & Barner assume that fake mass nouns combine with MASS is because they link quantifier selection to this head. However, since I will propose an alternative, namely that quantifier selection is linked to morphological plurality, it opens up the flexibility to eliminate the two methods of division, and have count nouns and fake mass nouns combine with the same dividing head.

The second point of difference between the theories is that I assume that fake mass nouns are plural, in addition to being divided. Since the plural value is inherent, following the assumptions above, I again assume that the inherent feature is located on n .⁸ This means that the structure of fake mass nouns is as follows:

⁸See also Moskal (2015b) for an argument from morphological locality that inherent number is located on category defining nodes.

(57)

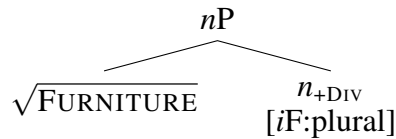

We can explain *pluralia tantum* nouns in a similar way. *Pluralia tantum* nouns are nouns that always control plural agreement, and show plural morphology themselves, irrespective of whether there is a singular or plural referent. An example from English is the noun *scissors*:

- (58) a. Those scissors are nice and sharp.
 b. Can you hand me all the scissors you see?

I assume here that they too combine with n_{+DIV} , but that instead of having an inherent number feature, the feature that lies on n is $[uF:\text{plural}]$. This would give the following:

(59)

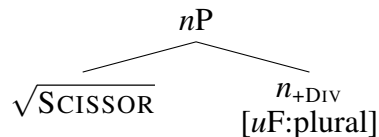

One might question why the number feature in such instances needs to go on the category defining node, rather than simply on the root. *Pluralia tantum* nouns give us a way to test between the two approaches. If the inherent information were exclusively on the root then we expect that inherent information is inexorably connected to the root, such that whenever the root appears, so does the inherent information. If the inherent information is however located on the category defining node, then we expect that if for some reason the root is prevented from appearing with the category defining node, then the inherent information should disappear. As it happens, inherent plurality can disappear in complex word formation in English:⁹

- (60) a. The goal was scored by a magnificent scissor-kick (*scissors-kick)
 b. Every hotel room used to have a trouser-press (*trousers-press)

⁹The plurality does not have to disappear. For instance *jeans-pocket* seems perfectly fine (?*jean-pocket*), as does *glasses-maker* (a person who makes glasses). However, this only shows that the category defining node can be used in compound formation, leading to the preservation of the inherent information. What is important to bear in mind though is that the examples in (60) shows that inherent information can be lost, which is unexpected on the view that inherent information is inexorably carried by the root.

I assume that the compound structures of the above are the following, crucially lacking a category defining node that combines with the *pluralia tantum* roots:

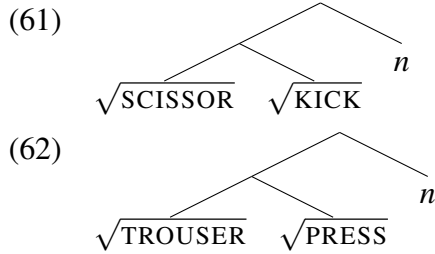

It remains to be answered how it is ensured that inherent features reliably end up with the roots that they are inherent to. In an approach where the inherent information lies literally on the root, this is no problem, however, when the inherent features are located in a position away from the root, it becomes a challenge to make sure that they line up correctly. In this regard, I follow Acquaviva (2008b) in assuming that the grammar includes knowledge of licensing relations of roots. Acquaviva proposes in essence that one must learn which category defining nodes can combine with which roots. If a root and a category defining node can combine, they are licensed. In gender systems for instance, roots are not fixed with a gender, but rather the learner must figure out that a certain root is licensed with an *n* that carries a certain gender. For instance, the root $\sqrt{\text{HOUSE}}$ in German is licensed to occur with *n* with a neuter gender, thereby giving the whole *nP* neuter gender, finally yielding *das Haus*. This system allows Acquaviva to analyze pairs of nouns that alternate in gender as being licensed by two different *ns*, without positing largely homophonous roots. For instance, in Italian, there is an alternation between *cugino* ‘male cousin’ and *cugina* ‘female cousin.’ Acquaviva states that there is a single root $\sqrt{\text{COUSIN}}$ that is licensed to appear with two separate functional heads, n_{MASC} and n_{FEM} , giving *cugin+o* and *cugin+a* respectively.

Returning to fake mass nouns and *pluralia tantum* nouns, we therefore assume that the class of fake mass nouns are all licensed to occur with $n_{+\text{DIV}}$ which carries [*i*F:plural]. *Pluralia tantum* nouns are licensed to occur with $n_{+\text{DIV}}$ which carries [*u*F:plural], as shown in (63), but not with any other type of *n*, as in (64) and (65).

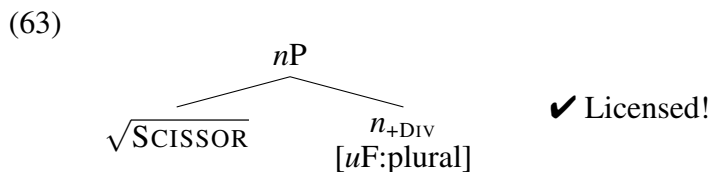

(64)

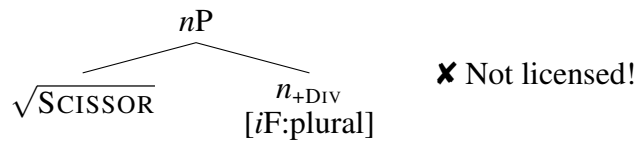

(65)

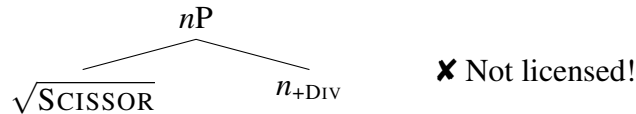

Crucially, given the discussion of (61) and (62) the licensing relation must be such that it holds only when the roots combine directly with n , not wherever the roots are merged into the structure. Thus, when a root like $\sqrt{\text{SCISSOR}}$ combines with n , it can only combine as in (63), but is able to combine with other things in a more free manner, to produce the root+root compounds above. Since in the root+root compounds, $\sqrt{\text{SCISSOR}}$ is not combining with (some type of) n , the licensing relations are not at play, and so there is no requirement that it combines with the right one. Note that when $\sqrt{\text{SCISSOR}}$ is the head of the compound, then plural morphology is obligatory (*kitchen scissors*, **kitchen scissor*). I assume that it is the head of the compound that determines the selectional properties of the compound as a whole.

(66)

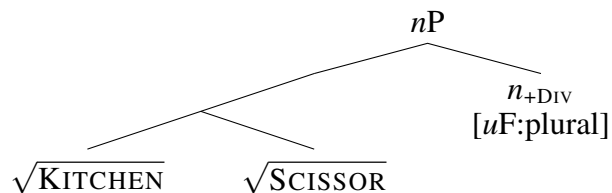

(67)

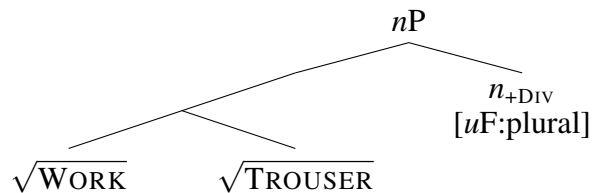

Finally, before moving away from this section it is worth considering the form *nail clippers* in depth. This compound is a *pluralia tantum* form, since it must combine with

plural morphology, control plural agreement on the verb, and does not combine with numerals without a measure phrase:

- (68) The nail clipper*(s) are on the table.
 (69) *The nail clippers is on the table.
 (70) There are three *(pairs of) nail clippers on the table.

This form seems to cause a problem for us at this point. I have assumed that plural morphology on *pluralia tantum* nouns comes from the $uF:plural$ feature that lies on n . Yet, in the example of *nail clippers*, there seems to be another morpheme that is realizing n , namely the *-er* suffix. Thus, n seems to be spelled out by two morphemes, *-er* and *-s*. Note that in other *pluralia tantum* nouns that we have seen, there is the same phonological ending /əz/. However, whilst there is no suggestion that this is segmentable into two identifiable heads (the ə is part of the root), with *nail clippers*, the /ə/ does seem to correspond to the agentive suffix *-er* of English, as in *teacher*, *driver*, etc. and the /-z/ comes from the plural suffix. The contribution of /ə/ is transparently the agentive suffix in the meaning of *nail clippers* – something that clips nails – whereas it is not in *scissors* – *something that scisses.

There are two ways out of this problem. One way out of this apparent problem is to assume that *-er* is not the spell-out of n , but rather is a root itself. This is compatible with the proposals in Lowenstamm (2010), de Belder (2011) and Creemers et al. (2015), who argue, each differing in details slightly, that derivational suffixes are not category defining nodes. Rather, they are roots themselves. Thus, the structure would be:

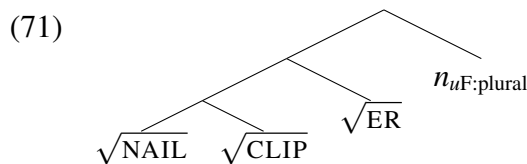

The second option is to assume that for a form like *nail clippers*, we have two distinct n heads, where the lower one is the agentive n and the second head is the *pluralia tantum* creating n . This structure would be:

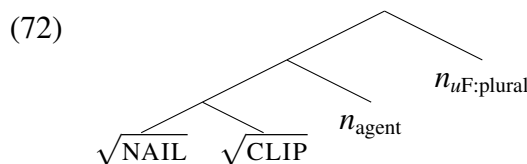

Either of these approaches works for our purposes here, and I do not make any commitment on which to adopt. It is notable however that whichever approach is taken, a

form like *nail clippers* offers further support for the approach taken here (where I follow Acquaviva 2008a) that the plural nature of *pluralia tantum* nouns lies not on the root, but that certain structures are licensed to appear with certain functional heads. There is no item in *nail clippers* which is inherently plural. However, the combination of $\sqrt{\text{CLIP}} + \text{-er}$ becomes a *pluralia tantum* noun. Thus, the combination of $\sqrt{\text{CLIP}} + \text{-er}$ is only possible under $n_{uF:\text{plural}}$ (cf. Marantz 1995).

2.2.4.2 The effect of inherent number

Returning to fake mass nouns, they are known to resist combination with plural morphology, far more so than regular mass nouns in English. Their resistance to plural morphology is to such an extent that they do not undergo mass to count shifts, which we would otherwise expect if they were regular mass nouns. This fact can be explained in the approach of Bale & Barner, since the fact that fake mass roots are inherently divided prevents them from combining with COUNT, which can only combine with unindividuated roots (per stipulation). In the present analysis, the inability of fake mass nouns to undergo mass to count shifts receives a somewhat deceptive explanation: they are never mass nouns to begin with. However, an apparently larger problem results in that they have the inner structure of count nouns since they combine with n_{+DIV} . Since they have the inner structure of count nouns, what is it that prevents them from acting like count nouns?

I propose that a root that combines with an inherent number specification cannot further combine with NumP in English.

- (73) Num⁰ cannot be realized on a lexical item that has an inherent number specification.

Suppose that a root combines with n carrying $uF:\text{plural}$. It cannot then combine with NumP in the same morphological word. There are then two strategies open at this point. Either, (i) NumP does not merge into the structure, and the derivation proceeds without it. Or, (ii) NumP does merge into the structure; in this case, it cannot combine with [root + n].

Option (ii) will be discussed below, but for now I focus attention on option (i). Option (i) has the consequence that no further number features are able to be added to fake mass nouns or *pluralia tantum* nouns. Thus, the only number information that is there is inherent number information, and non-inherent number information will not be present, given that NumP is where non-inherent number information is located. For fake mass nouns, this is a fairly striking consequence: it results in fake mass nouns not being able to co-occur with plural morphology. The inherent number information on fake mass nouns is only semantic, that is, the number feature is iF . For these nouns to receive morphological

number information, it would need to be introduced in NumP. Since inherent number and non-inherent number information cannot lie on the same lexical item (at least in English) then we predict that fake mass nouns cannot inflect for plural morphology. In the absence of any morphological number specification, I assume that they are spelled out with the unmarked value of the missing features, which for morphological number is singular (Bale et al. 2011). This means that they are morphologically singular by default. However, they also apparently control singular agreement:

(74) The furniture is starting to look shabby.

The singular agreement I treat here as default agreement also. In short, because there is no $uF:\#$ feature on the fake mass noun, T cannot agree with the fake mass noun for number. Thus, the number value on T remains unvalued, and is realized by default 3.SG (see Preminger 2011, 2015 on agreement being spelled out as default when an Agree relation cannot be established). One might question why the iF on the fake mass noun cannot donate the value, and fake mass nouns control plural agreement. This will be discussed in a lot more detail in chapters 3 and 4, however, to give the reader a preview, I propose that for iF s to control agreement in a language (giving rise to Semantic Agreement) they must be *active*. As a lexical class, fake mass nouns in English do not make their iF s active, and as such the $iF:\text{plural}$ is not able to enter into agreement. The result is therefore default 3.SG on the verb.¹⁰

The structure of a fake mass noun like *the furniture* is thus as follows:

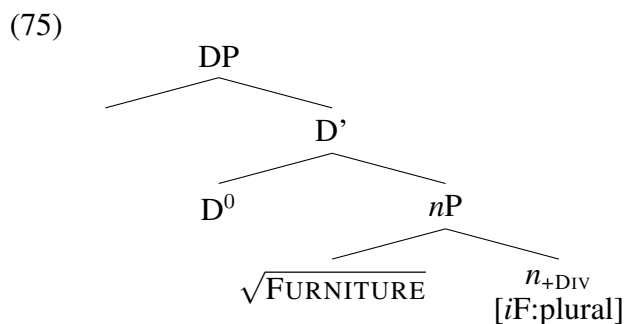

With *pluralia tantum* nouns, the picture is a little bit more complicated but largely the same. Since no non-inherent number will be able to be realized on the same lexical item, this means that *pluralia tantum* nouns will only carry their (inherent) morphology. The question is, what happens with their interpretation? The nouns will be divided, since they combine with n_{+DIV} , however, they are predicted to not be able to receive any number

¹⁰It is important to note that I am not assuming that a failure of agreement leads to a crash of the derivation, for instance Chomsky (2000, 2001). This issue will be returned to below in section 3.7.

*i*Fs. As with fake mass nouns, I propose that the missing information is filled in with the unmarked value, and since it is semantic information that is missing in this instance, not morphological information, it is the semantically unmarked value, which is plural. Thus, *pluralia tantum* nouns are interpreted in the same way as plural nouns. Note that this does not entail that *pluralia tantum* nouns will not be able to refer to singular entities, which is transparently not the case, as seen in (76) below. However, plural semantics does not exclude reference to singularities, as shown in (77) (Bale et al. 2011, Sauerland 2008).

(76) These scissors are the ones that cut me. (pointing to a single pair)

(77) If you have children, please raise your hand.

2.2.4.3 When NumP is present

Now I turn to option (ii) given above, when the structure necessitates that NumP is projected into the structure. We again predict that fake mass nouns and *pluralia tantum* nouns should pattern together very closely. Though fake-mass nouns do not combine with NumP on the same lexical item, there are configurations when they do combine with NumP. One of those instances is when they combine with a numeral, following Watanabe (2010) who proposes that numerals are introduced in the specifier of NumP. Count nouns, when they combine with a numeral, provide a host for the number features that are located on Num⁰. Fake-mass nouns however, are not able to do so due to their inherent number, and in order to provide the number features of Num⁰ with a host, I propose that a dummy lexical element is inserted. This is akin to dummy-do insertion in English, where *do* is inserted to host the tense features of the auxiliary when it is unable to combine with the verb.

Therefore, in the fake-mass structure that undergoes vocabulary insertion below, *piece* is inserted to provide a placeholder for the features on Num⁰, that otherwise could not be hosted:

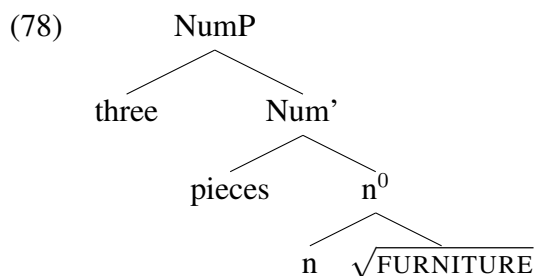

The dummy lexical element I assume to be the measure phrases of fake-mass nouns like *bit*, *piece* etc. Since they are dummy elements, this explains why they do not contribute much in the way of semantics, being only placeholders to support features, not inserted to

give extra information. Therefore, they are made to look like true mass nouns since they must combine with an apparent measure phrase in order to be counted, however unlike true measure phrases the ones that go with fake-mass nouns are not there to provide division, but are only there to host number features.

2.2.4.4 Cross-linguistic justification

(73) is given above as a condition that is present in English, and it is reasonable to wonder whether it holds universally. If so, and nouns that have inherent number can never be counted, then the claim made here is extremely strong. As it happens, this does not seem to be the case, since one can find various instances of languages that happily count *pluralia tantum* nouns. However, there are also various languages which do not allow direct counting of *pluralia tantum* nouns, and employ other strategies to get around this, suggesting that the inability to count nouns which have an inherent number specification is not limited to just English.

Firstly, Pesetsky (2012) shows that *pluralia tantum* nouns in Russian can only combine with collective numerals, such as in the following sentence, where *sutok* is *pluralia tantum*.

- (79) èt-i posledn-ie dvo-e strašn-yx sutok
 these-NOM.PL last-NOM.PL two.QUANT-NOM terrible-GEN.PL 24h-GEN.PL
 'These last two terrible days.'

Another case comes from Bosnian.¹¹ We see in this language that the same pattern holds as in Russian; *pluralia tantum* nouns cannot be directly modified by the paucal numerals (two, three and four), but a collective numeral must instead be used. However, there is an alternative way of counting for speakers of Bosnian where an adjectival numeral may be used (see Leko 1998):

- (80) četvere hlače
 four.ADJ pants
 'Four pairs of pants.'

This shows that there is nothing wrong with counting *pluralia tantum* nouns in general, however in certain languages, just as I propose in English, *pluralia tantum* nouns are not able to combine with the regular numerals of a language, but they are countable by other means. Crucially, with regard to the Bosnian data, it does not have to be a collective numeral, but rather just not the regular numeral.

¹¹Thanks to Aida Talić for the data on this.

2.2.5 What about quantifiers?

Finally, I turn to the issue of quantifiers. Recall that fake mass nouns undeniably combine with apparent mass quantifiers like *much* and *little* and not with count quantifiers like *many* and *few*. If count-mass nouns are to be analyzed as only looking like mass nouns, and not really mass nouns at all, as is the claim here, then the fact that these nouns go with mass quantifiers remains to be explained.

In the flexible roots approach, it is the syntactic structure that determines whether a noun is interpreted as being divided or not divided. For Borer (2005), division, and lack thereof was modeled in terms of dividing structure either being present or not in the structure. For Bale & Barner (2009), the difference was not the presence or absence of a certain bit of structure, but rather different functional heads. However, one aspect that unifies these approaches is that the difference in syntactic structure (however it is manifested) is what is responsible for determining whether a noun will appear with a mass or a count quantifier. In short, the view is that count quantifiers would merge with count structure, and mass quantifiers would merge with mass structure.

Linking quantifiers to structure in this manner makes intuitive sense, however, it necessarily means that all nouns that combine with mass quantifiers also combine with mass heads, with the same going for count nouns.¹² In the version of the flexible roots approach that I am proposing, this explanation is not possible. Since I am proposing that fake mass nouns combine with n_{+DIV} , the functional head that creates division, if we link quantifier choice to division, we would expect fake mass nouns to pattern with count, but not mass nouns, contrary to fact.

Here I propose that apparent mass versus count quantifier selection is in fact allomorphy that is sensitive to the morphological number status of a noun: both mass and count quantifiers are allomorphs of the same underlying quantifiers, with the count variant conditioned by morphological plurality and the mass variant being the elsewhere case. Specifically, I propose the following. In English, there are two (relevant) underlying quantifiers MUCH and LITTLE which merge with the noun. They undergo agreement with the noun that they quantify over and agree with the noun's number feature. That quantifiers can undergo agreement with the noun is known from *e.g.* Italian, where the quantifier that translates as *many* differs in form depending on the gender and number of the noun it combines with (*molti* versus *molte*).

Thus, I assume that the quantifiers carry a μF number feature that is unvalued, and undergoes agreement with the head noun in order to receive one. If this agreement ends

¹²Another prediction, made by both Borer and Bale & Barner is that there ought to be no instance of a non-individuated noun combining with a count quantifier. This prediction turns out to be wrong, as will be shown in section 2.3, and will be discussed there.

up with the quantifier having a plural number feature, MUCH is spelt out as *many* and LITTLE is spelt out as *few*. However, if the noun that is agreed with is not morphologically plural, then the elsewhere rules contained within (125) below are used, and MUCH is spelt out as *much*, and LITTLE as *little*.

- (81)
- | | | |
|--|-------------------|--------|
| $[\sqrt{\text{MUCH}}, uF:\text{plural}]$ | \Leftrightarrow | many |
| $[\sqrt{\text{LITTLE}}, uF:\text{plural}]$ | \Leftrightarrow | few |
| $\sqrt{\text{MUCH}}$ | \Leftrightarrow | much |
| $\sqrt{\text{LITTLE}}$ | \Leftrightarrow | little |

In this manner, count nouns will always combine with *many*, since MUCH will get a plural value for its *uF* number feature from the noun. However, both fake mass nouns and mass nouns, by virtue of lacking a number specification, will not donate any value to the quantifier. Thus, the quantifier will be spelled out as *much*.¹³ Derivations are given below. In (82), the quantifier receives a *uF* value from the plural features on Num⁰, resulting in count nouns valuing their quantifier *uF:plural*. We get the same result with *pluralia tantum* nouns in (85), although the value comes from the inherent number of *n*_{+DIV}. Both of these result in *many* spelling out MUCH, according to (81). In both (83) and (84), there is no *uF* number feature in the derivation for the quantifier to agree with. Thus, the *uF* on the quantifier remains unvalued, and is spelled out as *much*, per the VI rules in (81). Arrows in the following trees indicate agreement.

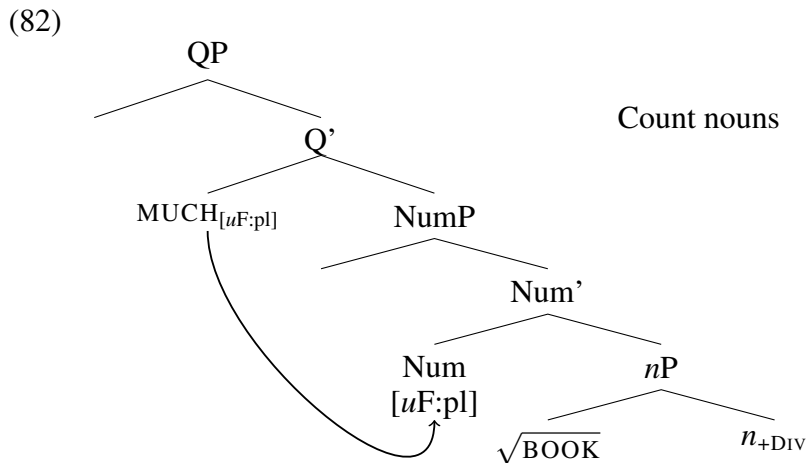

¹³The agreement must only target the *uF* number value of the head noun, otherwise it could result in fake mass nouns being able to combine with *many*, contrary to fact, as the quantifier could see the value of the *iF*. Looking ahead to the next two chapters, fake mass nouns do not make their *iFs* available to agreement (*active* in the sense of chapter 3 and chapter 4).

(83)

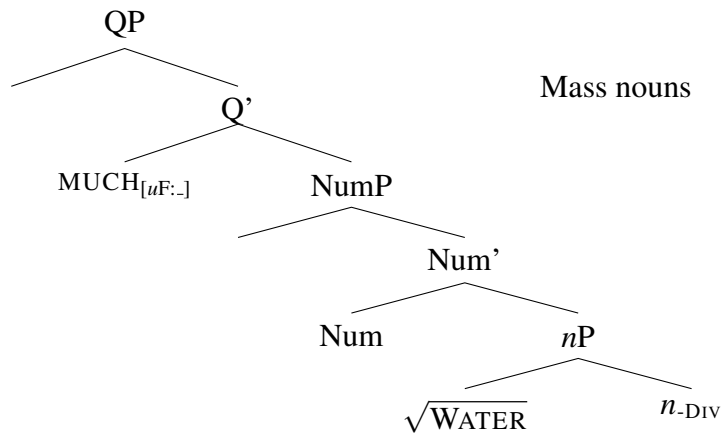

(84)

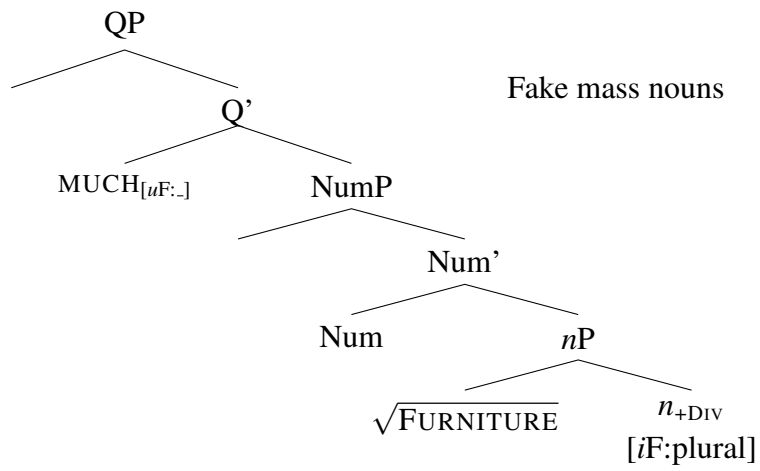

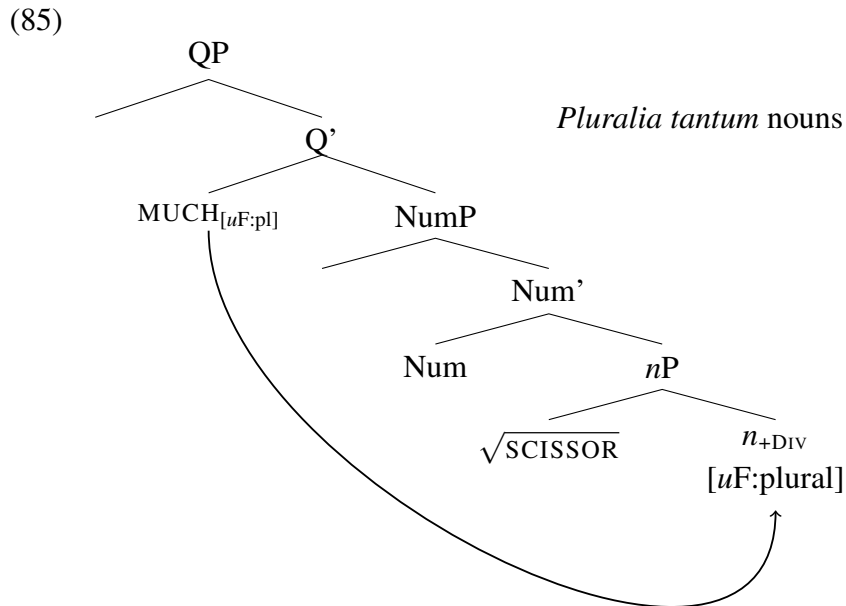

2.2.6 Fake mass nouns, woodchippers, and the Universal Grinder

Before moving on from fake mass nouns, there is one last issue to discuss: that of the Universal Grinder and how it interacts with fake mass nouns. The claim made throughout here is that fake mass nouns are inherently divided, as well as plural. Thus, the root $\sqrt{\text{FURNITURE}}$ must combine with $n_{+DIV} + iF:\text{plural}$, as per the licensing conditions discussed above in section 2.2.4.1 (see in particular (75)).

For some speakers of English, however, fake mass nouns can appear in a true mass usage. As mentioned earlier, English is quite free in that it allows (most) count nouns to be used in a mass use, and vice versa. Fake mass nouns don't appear to have such freedom. For instance, whilst it is possible with a true mass like *water* to shift its usage such that it appears with true count properties like *many*, *furniture* doesn't have the same level of freedom.

- (86) a. I brought many waters.
 b. *I bought many furnitures.

From the discussion here, it should be clear why fake mass nouns lack this freedom. We can model mass/count coercion as roots that normally appear with n_{+DIV} appearing

instead n_{-DIV} , and vice versa. Since fake mass nouns already combine with n_{+DIV} , then they cannot undergo a true n_{-DIV} to n_{+DIV} shift like *water* does in (86a). Since they necessarily occur with n_{+DIV} carrying iF :plural, which in turn prevents them from combining with NumP, they can’t obtain the necessary plural morphology needed to license *many*. However, some speakers allow for a shift to a true mass usage. Consider the following sentence, which is characteristic of the Universal Grinder effect that is a count to mass shift:

- (87) John put the furniture through the woodchipper, and now there’s furniture all over the back garden.

After the furniture has gone through the woodchipper, the result is not *furniture* in any sense of what one can sit on or such, but rather is likely to be chips of ground wood and so on. However, this seems to suggest that a fake mass noun can be separated from [n_{+DIV} + iF :plural], and should really be a violation of the licensing requirements in (75).

Rather than this cause a problem for the analysis assumed here, we can slightly weaken the licensing conditions of fake mass nouns. Recall from the discussion of *pluralia tantum* nouns within compounds that it is not an absolute requirement that a *pluralia tantum* root like $\sqrt{SCISSOR}$ appear with [n_{+DIV} + uF :plural]. In a compound like *scissor kick*, we see that the n carrying the inherent plurality is missing, and *scissor* appears in the singular form. Therefore, it does not cause ungrammaticality for a root that has licensing requirements to appear without a head. *Scissor* can also be used as a verb, so the root can combine with a different head also:

- (88) Pages scissored out of a magazine.¹⁴

Indeed, fake mass nouns can also be used as verbs, thus the requirement that fake mass roots combine with [n_{+DIV} + iF :plural] is not an absolute requirement:

- (89) a. We can’t wait to furnish our new apartment.
b. He mailed a letter.

The explanation is that the licensing requirement identified in (75) above holds only when a root like $\sqrt{FURNITURE}$ combines with n_{+DIV} . So, the only n_{+DIV} head that $\sqrt{FURNITURE}$ can combine with is [n_{+DIV} + iF :plural]. Combination with n_{+DIV} without iF :plural violates this, and is not licensed. The more specific needs of $\sqrt{FURNITURE}$ are not met by simple n_{+DIV} . However, the licensing requirement holds only over varieties of n_{+DIV} , and so only when $\sqrt{FURNITURE}$ tries to combine with n_{+DIV} . It is however free to combine with other heads, like v and n_{-DIV} . This explains why fake mass nouns can be used as true mass nouns

¹⁴This example taken from the Oxford English Dictionary.

once they are coerced to do so. Once they combine with n_{-DIV} , they will get an undivided interpretation consistent with other mass nouns, but of course they will still combine with the mass quantifier allomorphs *much* and *little*, since they don't get plural morphology, like other mass nouns.

Importantly however, the licensing conditions for when the root combines with varieties of n_{+DIV} are such that it cannot avoid having the inherent $iF:plural$ specification upon combination with this head. Therefore, we cannot subvert the inherent number in such a way to allow fake mass nouns to be able to combine with numerals and plural morphology. This would require them combining with a simple n_{+DIV} head without an inherent number specification. However, the more specific head [$+n_{+DIV} + iF:plural$] must always be chosen.

2.2.7 Interim Summary

In this section I have shown that fake mass nouns are not mass nouns in any traditional sense, but rather are made to look as though they are mass nouns in the way that English resolves inherent number. Thus, I drew a close comparison to *pluralia tantum* nouns, and showed that various properties that are shared between fake mass and *pluralia tantum* nouns result from both of these classes having inherent number. Importantly, a lot of the explanation was based on the result of a mismatch in number features. Fake mass nouns had a specification for semantic plurality, but could not get one for morphological number; *pluralia tantum* nouns had a specification for morphological plurality but did not receive any semantic number specification. In the next section I show that this general idea helps us understand another class of atypical mass nouns in Telugu. There I show that the current account of the flexible roots approach is to be preferred, since it helps account for something not predicted in the other accounts, namely the existence of (semantically) mass nouns that have count (morphosyntactic) properties.

2.3 Non-countable count nouns in Telugu

2.3.1 The mass/count distinction in Telugu

In this section I outline the fact that Telugu does have a mass/count distinction in the language, and that there are a clear set of diagnostics for distinguishing between count nouns and mass nouns. Telugu is therefore a language which makes a mass/count distinction.¹⁵ The Telugu data in this section come from my own fieldwork.

¹⁵Thus, it is not a language like Yudja that does not make such a distinction (Lima 2014). See also Wiltshko (2012) on Halkomelem Salish and Blackfoot which also do not make a mass/count distinction.

2.3.1.1 The morphosyntax of the mass/count distinction in Telugu

The first fact of note is that Telugu has a regular singular/plural distinction, that is shown in obligatory nominal and verbal morphology, as well as being reflected in the pronominal system. To show the nominal and verbal morphology, consider the following pair of sentences. In (90), we see that *kukka* ‘dog’ is present in the sentence without any number marking, and is used in a singular sense, shown by the presence of 3.NM.SG morphology on the verb. In contrast, in (91), we see that *kukka* now appears with the plural suffix *-lu*, in addition to triggering 3.NM.PL agreement on the verb.¹⁶

(90) *kukka tinn-a-di*
 dog eat-PAST-3.NM.SG
 ‘A dog ate.’

(91) *kukka-lu tinn-aa-ji*
 dog-PL eat-PAST-3.NM.PL
 ‘Dogs ate.’

Number morphology is obligatory for all nouns (aside from mass nouns as we will see), and does not become optional through inanimacy, as shown in (92) and (93) below:

(92) *oka niiLLa susaa table paina un-di/*unn-aa-ji*
 a water bottle table on be-3.NM.SG/be-PRES-3.NM.PL
 ‘A water bottle is on the table.’

(93) *renDu niiLLa siisaa-lu table paina unn-aa-ji/*un-di*
 two water bottle-PL table on be-PRES-3.NM.PL/be-3.NM.SG
 ‘Two bottles of water are on the table.’

As shown in (94), with the noun *isuka* ‘sand’, Telugu does not allow mass nouns to combine with the plural morpheme.

(94) * *aa abbaaji isuka-lu tavvu-tunn-aa-Du*
 the boy sand-PL dig-PROG-PRES-3.NONMASC.SG
 INTENDED: ‘The boy is digging sands.’

Count nouns in Telugu freely combine with numerals, in a manner much akin to English. Again, plural morphology on the noun is obligatory (for numbers two and above), and count nouns in Telugu do not require some measure/classifier phrase to combine with the noun in order for them to combine with numerals. This is shown in (95) below:

¹⁶In (90) and (91), and what follows, NM indicates non-masculine gender agreement.

- (95) Raaju muuDu aratipanD-lu tinn-aa-Du
 Raaju three banana-PL eat-PAST-3.MASC.SG
 ‘Raaju ate three bananas.’

Mass nouns on the other hand are not able to combine directly with numerals, (96) and require a measure phrase in order to do so.

- (96) * Raaju renDu isuka-lu konn-aa-Du
 Raaju two sand-PL dig-PAST-3.MASC.SG
 INTENDED: ‘Raaju dug two (piles of) sand(s).’

A final morphosyntactic diagnostic that we can use to identify the mass/count distinction in Telugu is with the quantifiers that translate in English to *few* and *little*. Telugu also has a difference like this, although with only a single quantifier. Unlike English, there is no difference between *many* and *much* in Telugu: both are expressed using the word *caala* as shown below in (97). However, there is an equivalent to the difference between *few* and *little* in Telugu, with the former expressed by *konni*, (98) and the latter by *koncam(u)*, (99):

- (97) a. raaju caala aratipanD-lu tinn-aa-Du
 Raaju a.lot.of banana-PL ate-PAST-3.M.SG
 ‘Raju ate many bananas.’
 b. raaju caala annam tinn-aa-Du
 raaju a.lot.of rice eat-PAST-3.M.SG
 ‘Raju ate a lot of rice.’
- (98) Raaju konni aratipanD-lu tinn-aa-Du
 Raaju few banana-PL eat-PAST-3.MASC.SG
 ‘Raaju ate few bananas.’
- (99) neenu koncamu uppu tinn-aa-nu
 I little salt eat-PAST-1.SG
 ‘I ate little salt.’

2.3.1.2 The semantic distinctions between mass nouns and count nouns in Telugu

Changing track to the semantic side, Telugu again patterns with English in a couple of diagnostics. The diagnostics that will be discussed are the ability to combine with *stubbornly distributive predicates*, see Schwarzschild (2011), and standard of comparison, as discussed by Bale & Barner (2009).

The first diagnostic is *stubbornly distributive predicates*. Recall that Schwarzschild (2011) shows that count nouns differ from mass nouns in their ability to combine with

predicates such as *large*, *round* and *long* in that count nouns can happily combine with these predicates, but mass nouns cannot.

Telugu also has a class of predicates that show this property. In the sentences below, I show this with the adjective *pedḍagaa*, which combines with count nouns such as *aratipanDlu* ‘bananas’, but not mass nouns like *vendi* ‘silver’, (100). By way of contrast, an adjective that does not obligatorily distribute, like *baruvugaa* happily combines with both count and mass nouns, (101), as in English.

- (100) a. aratipanD-lu pedḍa-gaa unn-aa-ji
 banana-PL big-GA be-PRES-3.NM.PL
 ‘The bananas are large.’
 b. # vendi pedḍa-gaa un-di
 silver large-GA be-3.NM.SG
 INTENDED: ‘The silver is large.’
- (101) a. aratipanD-lu baruvu-gaa unn-aa-ji
 banana-PL heavy-GA be-PRES-3.NM.PL
 ‘The bananas are heavy.’
 b. vendi baruvu-gaa un-di
 silver heavy-GA be-3.NM.SG
 ‘The silver is heavy.’

Telugu thus shows an identical distribution of stubbornly distributive predicates to English; there exists in Telugu (as in many languages - see Maldonado 2012) a set of predicates which must obligatorily distribute down to atomic entities, and these predicates happily combine with count nouns in Telugu, but not mass nouns.

Moving on to the second semantic diagnostic, Telugu also distinguishes count nouns from mass nouns with respect to comparison contexts. Count nouns are compared by number of individual entities and not any volume measurement, whereas mass nouns are compared with respect to the total volume of the mass noun, and the number of distinct individual quantities is irrelevant. Telugu also shows this pattern. Count nouns in Telugu are compared by number whereas mass nouns are compared by volume. The relevant sentences are given below. (102) is true when the number of bananas that Raju ate is larger than the number of bananas that Raani ate, whereas (103) is true when the overall quantity of oil is relevant, and not individual quantities, for instance bottles.

- (102) raaju raani kanna ekkuva aratipanD-lu tinn-aa-Du
 raaju raani COMP more banana-PL eat-PAST-3.M.SG
 ‘Raju ate more bananas than Raani.’

- (103) raajũ raani kanna ekkuva nuune konn-aa-Du
 raaju raani COMP more oil buy-PAST-3.M.SG
 ‘Raju bought more oil than Raani.’

The preceding discussion has established that there is a mass/count distinction in Telugu, and that it shares many properties with English. There are other properties relevant to the mass/count distinction in English that have not been discussed here. I leave investigation of these properties for future study, but the above discussion has established the existence of the mass/count distinction in Telugu, and now I move the discussion on to a small class of mass nouns that have plural morphology on them.

2.3.2 Milk and water: Plural mass nouns in Telugu

In section 2.3.1 the absence of plural morphology on a noun was used as a diagnostic of that noun being a mass noun. However, as has been noted in various places this does not hold without exception; cross-linguistically there are a small number of languages where plural morphology can appear on mass nouns. These will be discussed in section 2.3.2.2, but first I introduce the facts from Telugu, before discussing them in a wider context.

2.3.2.1 Milk and Water

As mentioned in section 2.3.1, an incompatibility with plural morphology is one of the hallmarks of the mass/count distinction in Telugu. However, as noted in Krishnamurti & Gwynn (1985), there are a small class of mass nouns in Telugu that occur with plural morphology. I focus my attention throughout this paper on two nouns, *niiLLu* ‘water’ and *paalu* ‘milk’, though it should be pointed out that the class of these nouns is larger than just two, and they are not limited to liquid mass nouns, see Krishnamurti & Gwynn (1985) for more details.¹⁷ Consider the following sentences. Note that the forms do not just look as though they are plural by virtue of ending in *-lu*, but they also trigger plural morphology on the verb that they agree with, and not singular morphology.

- (104) nii-LLu unn-aa-ji
 water-PL be-PRES-3PL
 ‘There is water.’
- (105) *nii-LLu undi
 water-PL be-3.NONMASC.SG
 INTENDED: ‘There is water.’

¹⁷I focus my attention to these nouns since they were the nouns that were easiest to elicit from my consultant. The other nouns listed in the grammar are *wadLu* ‘paddy’, *pesalu* ‘green gram’ and *kandulu* ‘red gram’.

- (106) paa-lu table miida padd-aa-ji
 milk-PL table on spill-PAST-3.PL
 ‘Milk spilled on the table.’

Interestingly, even though these nouns are prototypically mass in English, in Telugu they appear to show (at least a subset of) count properties. For instance, we see that they combine with the count quantifier *konni*, and not *končam*:

- (107) aa abbaaji konni nii-LLu taag-ees-tun-aa-Du
 the boy few water-PL drink-EMPH-PROG-PRES-3.MASC.PL
 ‘The boy is drinking some water.’
- (108) * končam nii-LLu
 little water-PL
 INTENDED: ‘Little water.’

One might suppose that it is expected that these nouns would appear with the count quantifier, since they exhibit plural morphology. For theories of the mass/count distinction like that espoused in Borer (2005), plural morphology is only possible if the noun root combines with the count syntax. Thus one may suppose that these nouns are simply count nouns in Telugu. However, it is not so clear that these nouns are count nouns since they do not exhibit the full range of count-properties, for instance, they are not countable without the aid of some measure phrase:

- (109) Raaju renDu *(kap-lu) nii-LLu taag-ææ-Du
 Raaju two cup-PL water-PL drink-PAST-3.MASC.PL
 ‘Raaju drank two (cups of) water.’

In addition to not being countable, these nouns also show the hallmark properties of having non-divided extensions and so being regular mass nouns. For instance, they do not combine felicitously with stubbornly distributive predicates, as shown in the following:

- (110) # nii-LLu peddagaa unn-aa-ji
 water-PL big-GA be-PRES-3PL
 ‘The water is large.’

Furthermore, they do not combine with quantifiers that require division, such as *prati* ‘every’:

- (111) * aa abbaaji prati niiLLu taag-ees-tun-aa-Du
 the boy every water-PL drink-EMPH-PROG-PRES-3.MASC.SG
 INTENDED ‘The boy is drinking every water.’

Finally, as is the case with mass nouns, comparison is done by volume, crucially not by number. In the following situation, (112) is true is a situation where Raaju used one 5 liter bottle of milk and Raani used three 1 liter bottles. Thus, the overall volume of milk used by Raaju was larger than that used by Raani, even though Raani used more individual portions of milk. It is *not* true if Raaju used three 1 liter bottles of milk and Raani used one 5 liter bottle, where the number of individual portions of milk used by Raaju is greater than the number used by Raani.

- (112) Raaju Raani kannā ekkuva paa-lu vaaD-ææ-Du
 Raaju Raani COMPR more milk-PL use-PAST-3.MASC.SG
 ‘Raaju used more milk than Raani.’

2.3.2.2 Plural mass nouns: A cross-linguistic picture

As was mentioned earlier it is not unheard of for mass nouns to occur with plural morphology. English for instance has a productive process of coercing a mass noun into count usage, which then allows a noun that usually occurs as a mass noun to be a count noun. However, this is not strictly a case where a mass noun is used with plural morphology, since the mass noun is in essence count.

A second way that mass nouns occur with plural morphology is when they have some kind of abundance reading. This is shown in the following example from Halkomelem Salish (Wiltschko 2008).

- (113) tsel kw’êts-lexw te/ye shweláthetel
 1SG.S see-TRANS-3O DET/DET.PL fog.PL
 ‘I’ve seen a lot of fog.’

The same pattern is seen in Greek (Tsoulas 2007), where the use of the plural suffix on the mass noun gives rise to the reading that a lot of the noun was involved:

- (114) Trexoun nera apo to tavani
 drip-3RD-PL water-PL-NEUT-NOM from the ceiling-NEUT-SG
 Water is dripping from the ceiling.

Tsoulas notes that these nouns come with an abundance reading, in that the quantity of water denoting by *tavani* in (114) is more than one would otherwise expect. Tsoulas gives the following dialogue to illustrate this point:

- (115) SPEAKER A: Afise o gianis anihto to lastiho ke gemise i avli nera
 (Giannis left the hose on and the yard was full of waters)
 SPEAKER B: Min ipervalis fofo mu, de gemisame nera, na ligo nero#nera etrekse.

(Dont exagereate Fofu, it wasn't full of waters, just a little water/#waters dripped out of the hose)

There is another type of example whereby plural morphology appears on what otherwise looks like a mass noun. Consider the following data from Ojibwe, from Mathieu (2012):

- (116)
- | | | | | |
|----|------------|-----------|----------------|--------------|
| a. | maandaamin | 'corn' | maandaamin-ag | 'corn-PL' |
| b. | semma | 'tobacco' | semaa-g | 'tobacco-PL' |
| c. | mikwam | 'ice' | mikwam-iig | 'ice-PL' |
| d. | azhashki | 'mud' | azhashki-in | 'mud-PL' |
| e. | aasaakamig | 'moss' | aasaakamig-oon | 'moss-PL' |

All of the nouns in (116) are prototypically mass nouns, but they appear to freely combine with plural morphology. Number in Ojibwe is not derivational, as Wiltschko (2008) claims to be the case for Halkomelem Salish. Mathieu also shows that the plural forms do not come with an abundance reading that is present in similar nouns from Halkomelem Salish. What they come with is in fact an individuated reading. Thus, they are akin to mass to count shifts, like *three waters* in English. However, the process is slightly different, since in Ojibwe it results from a singulative operation. Their individuation is shown by the fact that they can combine with numerals, as well as distributive quantifiers like *gakina* 'every':

- (117)
- | | | |
|----|------------------|-----------------------|
| a. | bezhig azhashki | |
| | one mud | 'One chunk of mud.' |
| b. | niizh azhashki-n | |
| | two mud.PL.IN | 'Two chunks of mud.' |
| c. | gakina azhashki | |
| | every mud | 'every piece of mud.' |

It might be tempting to wonder whether *niiLLu* and *paalu* fall into either of these classes of plural mass noun. However, these nouns are certainly not of the former type, since my consultant states that *niiLLu* and *paalu* are able to be used when only a little amount of milk and water is intended. Also, in the following situations, an abundance use of the mass noun would render the sentence infelicitous, however the sentences are fine:

- (118) Raaju tana coffee-lo paa-lu poos-ææ-Du
 Raaju his coffee-in milk-PL pour-PAST-3.MASC.SG
 ‘Raaju put milk in his coffee.’
- (119) Raaju čet-la-ki nii-LLu poos-ææ-Du
 Raaju plant-PL-DAT water-PL pour-PAST-3.MASC.SG
 ‘Raaju gave the plants water.’

Neither are these two nouns the result of a singulative shift, since, they do not come with an individuated interpretation (see the above discussion).

To summarize, here is the situation with Telugu count nouns, mass nouns and *niiLLu* and *paalu*:

(120)

	Count nouns	Mass Nouns	<i>niiLLu</i> and <i>paalu</i>
Plural morphology	✓	✗	✓
Combine with <i>konni</i>	✓	✗	✓
Combine with <i>končam</i>	✗	✓	✗
Directly countable	✓	✗	✗
Combine with <i>praṭi</i>	✓	✗	✗
Distributive predicates	✓	✗	✗
Comparison by	Number	Volume	Volume

The table nicely shows the split that *niiLLu* and *paalu* have. The top three rows show that they share their morphosyntactic characteristics with count nouns, but the bottom four rows show they are interpreted in the same way as true mass nouns.

2.3.2.3 Issues that Telugu raises for theories of the mass/count distinction

Since *niiLLu* and *paalu* in Telugu are clearly plural nouns, in Borer’s (2005) system it *must* be the case that they occur in a count structure like (35), since plural inflection comes about through CIP. Since CIP is in the structure, we would expect that the denotation of *niiLLu* and *paalu* is like any other count noun, with division. However, as shown by the discussion above, *niiLLu* and *paalu* do not show any sign of being divided; recall that these nouns are not countable, do not combine with *praṭi*, do not combine felicitously with stubbornly distributive predicates, nor do they allow for comparison by number, only by volume. They are practically the definition of an undivided noun if we take all of these properties to be indicative of division.

Now, one could argue that CIP is not present with *niiLLu* and *paalu*, and that the plural morphology is a decoy. Supposing that the plurality on the noun is inherent to the root, and not regular plural inflection that comes about through the syntactic structure, then it is possible in principle to maintain the view that *niiLLu* and *paalu* occur without CIP. However,

there is an additional problem in that the presence of the count structure with *niiLLu* and *paalu* is also shown by the quantifier selection. Recall that some quantifiers are sensitive to whether the nouns they quantify over is mass or count; *many* for instance will only go with count nouns. Borer treats this in terms of phrasal selection: because the mass/count distinction is created syntactically, and not through lexical properties, then quantifier sensitivity to the mass/count distinction must also be a sensitivity to syntactic environment. Borer says that *much* is a mass quantifier because it selects a phrasal complement that is mass; i.e. it does not have CIP. *Many* on the other hand is a count quantifier because *many* selects for a phrasal complement that contains CIP. Applied to *niiLLu* and *paalu* the problem that arises is the fact that *konni* surfaces with *niiLLu* and *paalu*, but *končam* does not, showing that CIP *must* be in the structure; in Borer's system it is not possible for *konni* to come about through any inherent factors.

Bale & Barner (2009) offer a different view of the syntactic creation of mass versus count. Their approach avoids some of the problems of Borer's, since plural morphology is allowed to coexist with mass nouns. Unlike Borer's approach, plural morphology is not strictly tied to count nouns.

Since B&B have two functional heads, one for creating countness and one for creating massness, it is in principle possible for both to co-occur on the same noun. However, there are two problems with this. Firstly, supposing that the two heads could co-occur, it seems reasonable to assume that COUNT would be the uppermost head, since this would be the one most local to the quantifier for means of selection. *NiiLLu* and *paalu* both appear with the count quantifier, therefore, when the count quantifier merges into the structure, it can only do so with a noun that is count. In order to prevent mass quantifiers from occurring with *niiLLu* and *paalu*, it is necessary to rule out optionality if two heads coexist, therefore it seems reasonable to assume that the highest head wins, as is standard with phenomena like agreement.¹⁸ Thus, the surface behavior of the nouns leads us to expect the following:

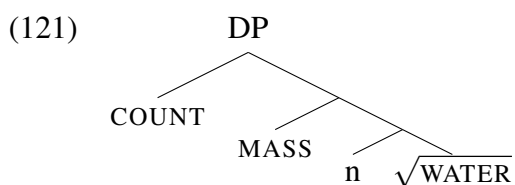

However, supposing that this were possible, when this structure is interpreted by the semantics, we still expect division, since COUNT will always yield an individuated interpretation to what it applies to. In fact, the problem is more general; since MASS is an

¹⁸This problem is circumvented if quantifier selection is done with reference to whichever head is closest to the root. However, this seems *ad hoc* and unmotivated. In addition, the problem with COUNT and MASS co-occurring in a meaningful way will remain.

identity function, then whenever COUNT is in the structure we will still get division. Even if the order of COUNT and MASS were reversed, as in (122) then MASS will map an individuated semi-lattice to itself. No matter what we do, with MASS being an identity function, anything with COUNT will yield division.

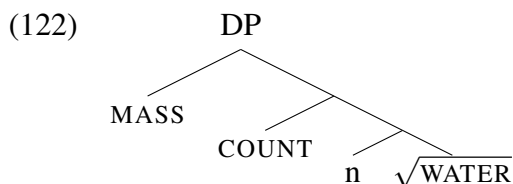

Two options present themselves at this point. The first option would be to define MASS in such a way such that MASS destroys division, and is a function that maps any type of lattice to an unindividuated semilattice. However, this then would give an apparent paradox in that the semantics would suggest that (122) is the correct structure whilst the morphology suggests (121). Furthermore, moving outside of Telugu, this approach would then fail to account for fake-mass nouns in English, which would then be expected to be unindividuated, contrary to fact, see Doetjes (1997), Bale & Barner (2009) and section 2.2 for discussion.

2.3.2.4 Summary

The approaches listed above face two major problems. Firstly, a problem that is limited to Borer (2005) and does not affect B&B too much is that plural inflection in Borer's system entails that CIP, the head that creates division, is there. This means that *any* noun that is marked as plural must be divided. We have already seen that there are cases where there are plural mass nouns in other languages, and here it seems that plural inflection does play a role. In singulative systems, plural inflection is regular plural inflection (though division is done elsewhere). In the languages where a plurality of mass nouns gives rise to an abundance reading, it is fairly intuitive that plural marking has created some division, even though it may be vague, since it has apparently served to introduce some standard amount that can be compared to. However, this is not the case in Telugu: there is no evidence that any kind of division at all has been created. Therefore, there is serious doubt that CIP is in the structure at all.

A second issue that affects both of these approaches comes from linking quantifier selection to the presence of a head in the structure. For both Borer and B&B, the fact that *niiLLu* and *paalu* both combine with *konni* entails that the head that creates division must be in the syntax. Thus, when it gets interpreted we expect a divided interpretation, which is not the case. The problem seems to be that both approaches are too coarse in tying count quantifiers strictly to divisibility. An approach that is to prove satisfactory needs to

at least include the following two components. Firstly, MASS and COUNT need to be able to combine in a meaningful way; and secondly, COUNT needs to be in the structure but only relevant for the morphosyntax, not semantics. In the next section I move towards an account which can handle this.

2.3.3 Quantifier allomorphy again

We have seen that one of the main problems for Borer and B&B's approaches is that, for both, the dividing head must be in combination with *niiLLu* and *paalu*, which means that the noun must be interpreted as having minimal parts. What I will begin to outline in this section is a way of allowing whatever it is that creates division to be present on the noun, but only play a role in the morphosyntax and not having any import into the semantics.

The split feature approach advocated for here however provides a new way of looking at things. Representing features in this manner allows for differences between how the morphology sees some item and how the semantics sees it. Its relevance for the matter at hand, where we need a noun to be morphologically count but semantically mass, is clear, and I now return to *niiLLu* and *paalu* in Telugu to move towards an analysis of these plural mass nouns.

2.3.3.1 A feature split approach to *niiLLu* and *paalu*

As in the above analysis of fake-mass nouns in English, the presence of *konni* also does not imply that the division head is in the structure. Quantifier selection is again agreement, and I will show that *konni* is possible if it can agree with [*uF*:-singular] on a noun.

The first thing of note is that Telugu fills a hole in the typology predicted in section 2.2. There it is argued that fake mass nouns are not really mass nouns at all, but rather are made to *look* mass by virtue of being semantically plural, but they lack a morphological specification for number. This meant that they were essentially count nouns in terms of their semantic behavior, but mass nouns in terms of their morphological behavior. We then predict that the converse mismatch is possible: that there exists a set of nouns that are semantically mass yet morphologically count. This is apparently unattested in English¹⁹ but stands as a prediction made by the approach where the surface and semantic behavior of mass and count can diverge. Telugu seems to fill in this typological prediction with *niiLLu* and *paalu*, as shown in the following table, with the grey shading indicating mismatches.

¹⁹To the best of my knowledge, though *suds*, as pointed out by Acquaviva (2008a) stands as a possible candidate.

(123)

	Semantics		
	+Count	Regular count noun	+Mass
Morphology	+Count	Regular count noun	<i>niiLLu</i> and <i>paalu</i>
	+Mass	Count-mass nouns	Regular mass noun

I propose that we understand Telugu in the following way. The plural specification on *niiLLu* and *paalu* is not regular plural inflection like it is with a count noun, but rather arises because these nouns are inherently *morphologically* plural. Recall that I assume that inherent features are located on category defining nodes, therefore $\sqrt{\text{WATER}}$ must combine with an *n* that carries [*uF*:plural]. Importantly, since these nouns are *not* individuated, they must combine with *n*_{-DIV}. Note that there is no semantic contribution of the plural feature: *niiLLu* and *paalu* are not semantically plural but only morphologically. Since they combine with [*uF*:-singular], they appear with the plural suffix.

(124)

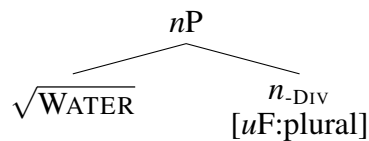

We still must explain the facts about quantifiers. Recall that the biggest problem for the approaches of B&B and Borer (2005) was that the presence of an apparently count quantifier necessarily entailed the presence of a syntax that produces semantic division. A central argument of section 2.2 is the fact that English count-mass nouns appear with apparent mass quantifiers does not entail the fact that they appear with the functional head that prevents division (i.e. MASS). Apparent selection of quantifiers for masshood and countness was treated as allomorphy of the quantifier MUCH, which has the allomorphs *much* and *many*. I again assume that the quantifier agrees with its noun in terms of number, and takes the *uF* value of the noun. Quantifiers are therefore valued as either singular, plural or without number. The allomorph of the quantifier is determined by the following VI rules operative in English. In short, *many* only appears when the noun that it appears with is morphologically plural (the same as with *few*):

- (125)
- | | | |
|---|---|--------|
| $\sqrt{\text{MUCH}}$, [<i>uF</i> :plural] | ⇔ | many |
| $\sqrt{\text{LITTLE}}$, [<i>uF</i> :plural] | ⇔ | few |
| $\sqrt{\text{MUCH}}$ | ⇔ | much |
| $\sqrt{\text{LITTLE}}$ | ⇔ | little |

We can also apply this same idea to Telugu to understand the quantifier facts, and see that the same pattern emerges: *končam* and *konni* are not separate quantifiers in Telugu that

are sensitive to the mass or count status of the nouns that they combine with, but rather they are allomorphs of a single quantifier FEW that are sensitive to the morphological number value of the noun that they combine with. I assume again that an agreement relation is established between the quantifier and the noun, and the quantifier contains a number feature that gets valued by the noun. Since *niiLLu* and *paalu* are valued as [*uF*:-singular], then we expect that they pattern with count nouns in terms of which quantifier they appear with due to the following VI rules for Telugu:

$$(126) \quad \begin{array}{l} \sqrt{\text{KON}\check{\text{C}}\text{AM}}, [\textit{uF}:\textit{plural}] \Leftrightarrow \textit{konna} \\ \sqrt{\text{KON}\check{\text{C}}\text{AM}} \Leftrightarrow \textit{kona}\check{\text{c}}\text{am} \end{array}$$

With these VI rules, we can see why *niiLLu* and *paalu* behave the way that they do in Telugu. What makes them appear to be count nouns - the plural morphology and the fact that they combine with an apparently count quantifier - is really a result of them being inherently morphologically plural.

2.3.4 Conclusions

This section outlined the mass/count distinction in Telugu, and shown that it does have an mass/count distinction in the same manner that a language like English does. I have further shown that there are mass nouns that are clearly semantically mass yet are morphologically plural. These nouns pose a problem for the theories of Borer (2005) and Bale & Barner (2009) since those approaches would predict that the nouns were divided, since plural morphology and the apparent selection for *konna* means that they should be in combination with a head that creates division. That these nouns are interpreted as if they are not divided evidenced the need for a more fine grained analysis of the mass/count distinction, where a noun is able to show the surface properties of being count, but the semantic properties of being mass.

2.4 Mass/count quantifiers as allomorphy

In both Telugu and English, I argue that mass versus count quantifiers is essentially reducible to allomorphy. The English quantifiers *many* and *much* are allomorphs of the same quantifier MUCH, whilst *few* and *little* are allomorphs of the quantifier LITTLE. ‘Count’ quantifiers (*many* and *few*) are the allomorphs that appear when the quantifier has undergone agreement and received a plural value, whereas ‘mass’ quantifiers (*much* and *little*) are the elsewhere variants. As explained above, treating mass versus count quantifiers in this way allows for a more nuanced understanding of how fake mass nouns in English

fit into the picture. We no longer need to analyze fake mass nouns in English as being true mass nouns, which in turn allows us to capture their variation from mass nouns in an intuitive way: they do not act like other mass nouns because they are not. This view however, has been considered before in unpublished work by Chierchia, and has not proven uncontroversial. Solt (2009) in particular provides criticisms against this position, arguing in favor of there being a genuine division between mass and count quantifiers. In this section, I consider the criticisms against the allomorphy approach, not only from the point of view of English, but also giving data from Purépecha, a language which seems to provide even more evidence against the allomorphy approach, but I will show that this language is in accord with the view that mass/count quantifiers are created by allomorphy.

2.4.1 Plural mass nouns in English

Solt criticizes Chierchia's approach on the following three observations:

1. The choice of a quantifier determines the interpretation of the noun.
2. In certain instances *many* and *much* can appear in the same syntactic environment.
3. Plural mass nouns (in English) seem to go with *much* instead of *many*.

Regarding point 1, Solt argues that if quantifier choice were determined by agreement, then we do not expect there to be any restrictions on the interpretation on the quantifier. Se gives the following examples:

- (127) a. SPEAKER A: How many potatoes did you buy?
b. SPEAKER B: Five.
c. SPEAKER B: # Two pounds.

From this, Solt argues that *many* fixes the interpretation of *potatoes* to an interpretation of number. However, this argument is undermined by the fact that *potatoes* is clearly a count noun in these example, and given that it can be used in a mass usage, the natural interpretation is to interpret it as a count noun. Once we switch to a clear plural mass noun, then we see that the *many* does not necessarily entail a number interpretation, but other measurements are available:

- (128) a. SPEAKER A: How many clothes did you bring?
b. SPEAKER B: # Three.
c. SPEAKER B: Three suitcases worth.

The second argument that Solt uses is that *many* and *much*, can appear in the same syntactic environments, which one would not expect if they were allomorphs of each other (in which case we would predict complementary distribution):

- (129) a. We invited many more than 100 people.
 b. ??We invited much more than 100 people.
- (130) a. ?We waited for many more than twenty minutes.
 b. We waited for much more than twenty minutes.

The third point is described by Solt as the strongest evidence that agreement does not play as big a role in determining quantifier selection as I am proposing here. It is a claim which has appeared in numerous places (e.g. Ojeda 2005), and is worth considering in more detail. Solt uses food examples like *mashed potatoes* and *scrambled eggs* to illustrate her point:

- (131) a. Everyone likes these/*this mashed potatoes.
 b. The mashed potatoes are/*is cold.
- (132) a. How much mashed potatoes should I make?
 b. *How many mashed potatoes should I make?

To the extent that these data are correct, then according to Solt they constitute strong evidence that there is something other than agreement at play in determining the distribution of *much* and *many*. The argument is as follows. The agreement on the demonstrative in (131a) and the verbal agreement in (131b) are both clearly plural, identifying the entire noun *mashed potatoes* as plural. Thus, if it were the case that plural morphological agreement always led to *many*, then we expect that nouns like *mashed potatoes* would always combine with *many*, irrespective of its interpretation. However, as shown by the grammaticality of (132a) and ungrammaticality of (132b), *mashed potatoes* combines with *much*, and not *many*. Since *mashed potatoes* has a mass reading, whilst being morphologically plural, Solt concludes that it is the mass status of *mashed potatoes* that is responsible for combination with *much*, and from this, it is MASS and COUNT that determine quantifier selection, and not morphological agreement, as is claimed here. This class of nouns then seem to be problematic. However, the picture is further complicated for two reasons.

Firstly, Solt's arguments regarding *mashed potatoes* are undermined somewhat in that agreement is not always uniform. *Mashed potatoes* can also be used with singular agreement:

- (133) Mashed potatoes is on the menu.

The singular agreement presumably comes from shifting *mashed potatoes* into a naming usage, which causes the internal morphology of the name to be ignored:

(134) Human resources is a great department to work in.

It seems like speakers are able to shift *mashed potatoes* into this usage:

(135) As a meat and potatoes kind of guy, mashed potatoes is my favorite side dish.

I propose that this shifting results in the internal morphology of *mashed potatoes* being ignored for the allomorphy of the quantifier, and the result is that *mashed potatoes* can appear with *much*. Note that the phrase can also appear with *many*, where it apparently is not treated as a named item:

(136) I don't know how many mashed potatoes you put in, but you were wrong.

That we are dealing with different usages of *mashed potatoes* is shown by the impossibility of combining them. In the following, we see that plural agreement is not possible when *much* quantifies over *mashed potatoes*, and singular agreement is not possible with *many*:

- (137) a. How much mashed potatoes is eaten on Christmas Day?
 b. * How much mashed potatoes are eaten on Christmas Day?
 c. How many mashed potatoes are ready?
 d. * How many mashed potatoes are ready?

Secondly, in English, it is clear that fake mass nouns like *furniture* as detailed above, do not fit the pattern that Solt predicts. Thus, both the morphological approach and Solt's semantic approach face issues in that there is one class of nouns that cannot be accounted for. In the morphological approach, plural mass nouns in English cause problems, whereas fake mass nouns cause problems for the semantic approach.

I contend here that the morphological approach is correct, and that (some) English plural mass nouns like *mashed potatoes* and *scrambled eggs* are idiosyncratic exceptions to the general rule. There are two pieces of evidence that support this view. Firstly, as shown in section 2.3, other languages clearly have morphological number, rather than semantic interpretation determining quantifier selection. The primary case in point is Telugu, where nouns with mass semantics combine with count quantifiers, because of their morphological number:

- (138) aa abbaaji konni nii-LLu taag-ees-tun-aa-Du
 the boy few water-PL drink-EMPH-PROG-PRES-3.MASC.PL
 'The boy is drinking some water.'

- (139) $\sqrt{\text{KONČAM, [uF:plural]}} \Leftrightarrow \text{konni}$
 $\sqrt{\text{KONČAM}} \Leftrightarrow \text{končam}$

Furthermore, the data from English are not as clear cut as it seems from (132). The judgements cannot be taken as too reliable, since they are often fuzzy, with relatively few nouns that people have clear intuitions about. A corpus search highlights this even further. These results come from searching for the plural mass noun, with either *many* or *much* within 2 surrounding words to the left of the noun serving as a direct quantifier, and not part of a partitive phrase like *how much of your knowledge...* The nouns picked were selected from looking at frequently cited plural mass nouns in the literature, as well as a subset of the plural mass nouns given by Ojeda (2005). Since *much* has other uses, all instances where *much* was clearly *not* being used as a quantifier were discounted from the totals.²⁰

(140)

Noun	Number of hits	MANY	MUCH
clothes	30450	62	0
belongings	1933	4	0
preparations	2719	2	0
valuables	445	3	0
fumes	1689	2	0
goods	17009	27	4
brains	5360	1	0
dregs	285	0	0
suds	264	0	0
guts	2984	0	0
contents	6145	0	0
remains	5137	5	0
winnings	670	0	0
ashes	3088	1	0
wages	7500	0	0
intestines	689	0	0

Given the scarcity of any of these nouns combining with *many* or *much* in the corpus, it is hard to draw any firm conclusions about whether plural mass nouns in English combine with mass or count quantifiers. What we can take away from this however, are two significant observations. Firstly, with the majority of these nouns, if they go with a quantifier, there is a preference to combine with *many* rather than *much*. Secondly, even if one

²⁰The corpus search was done on November 3rd, 2014.

were to disagree that there is a preference for *many* over *much*, given the scarcity of the results, it is hard to sustain an argument that *much* should be treated as ‘the quantifier’ for combining with plural mass nouns in English. Ultimately, the data are messy and the few clear cases that have a preference for *much* (*mashed potatoes*) are matched by those where there is a preference for *many* (*clothes*). The point to be taken away from all of this is that plural mass nouns in English do not suffice as an argument against the morphological approach to quantifier selection.

There is potentially a true argument against morphological quantifier selection that comes from ellipsis.²¹ Consider the following data:

- (141) a. Bagels, I have many, doughnuts, I don’t.
 b. *Bagels, I have many, cream cheese, I don’t.

The contrast in (141) looks problematic since the sentence appears to be ungrammatical when the quantifiers don’t match. What looks to be happening is that there is a clash of two different quantifiers, which violates the parallelism requirement of ellipsis. If we are dealing with the same quantifier, then this is surprising, since allomorph selection shouldn’t matter for ellipsis.

However, the force of this problem is slightly weakened by the fact that quantifier mismatches are allowed under ellipsis when it is *much* that is the first quantifier, and *many* that is the elided one. In the following (142b) seems more acceptable than (141b):

- (142) a. As for bagels, I don’t have many, but doughnuts, I do.
 b. ?As for cream cheese I don’t have much, but bagels, I do.

This contrast is reminiscent of another contrast seen in ellipsis shown by Bobaljik & Zocca (2011), but to do with gender marking. Consider the following:

- (143) a. John is an actor and Mary is too.
 b. # Mary is an actress and John is too.

In (143), we see something a similar with the relation between *actor* and *actress*. Whereas *actor* can have both male and female referents, *actress* can have only female referents. *Actress* is thus a more specific term than *actor*. However, by being more specific, it does not allow for ellipsis in (143b). It is similar with the quantifiers. One can say that *many* is a more specific form than *much*, since it only occurs with plural nouns, whereas *much* appears elsewhere. It is tempting to find a similar explanation for the quantifier ellipsis facts as the gender ones.

²¹Thanks to Jon Gajewski for pointing out this data to me.

The analysis given in Bobaljik & Zocca (2011) appeals to presuppositions triggered by phi-features. In short, the reason why (143a) is fine is because *actor* introduces no presupposition about gender. Parallelism can be satisfied in the elided section because even though *actress* violates parallelism, *actor* can be chosen as the elided noun, since it introduces no presupposition about Mary, whilst being consistent with her feminine gender. In (143b) on the other hand, because *actress* introduces a presupposition of feminine gender, the sentence must be bad; if *actor* is chosen as the elided noun, then it violates parallelism, but if *actress* is chosen, then it clashes with the gender of John.

Now, using presuppositions in the same way will not work for the problem of quantifiers here, because in the *many* versus *much* paradigm, we are dealing with *uF* features, which are not semantic in nature. However, a unified proposal does seem possible if we understand the gender distinctions in a different way. Let's assume that *actor* and *actress* differ in that *actor* comes from (144), without a gender specification, whereas *actress* comes from (145), where feminine gender is carried on *n*:

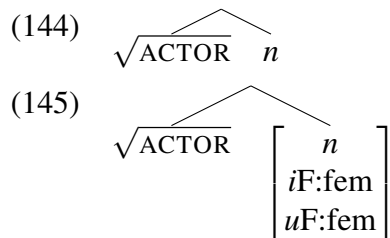

Let's further suppose that ellipsis can be licensed under the following condition:²²

- (146) A more specified representation cannot serve as the antecedent for ellipsis for a less specified representation.
- (147) Representation A is more specified than B if A properly includes B.

Under this condition, *actress* is allowed to be elided in (143a), because (144) is more specified than (145). However, since (145) is crucially more specified, it is not allowed to license ellipsis of *actor*, since (144) is less specified than (145). Using this, we can account for the difference between two classes of gender mismatches in Bobaljik & Zocca (2011). The first type are the *actor/actress* type, whereby there is an opposition between genderless nouns and feminine nouns. However, Bobaljik & Zocca note another class, that of nouns of nobility and kinship, where the same pattern is not observed. In these instances, neither can license ellipsis of the other:

²²This is by no means the only licensing condition on ellipsis, but a full discussion of ellipsis lies well beyond the scope of this dissertation.

- (148) a. # John is a prince and Mary is too.
 b. # Mary is a princess and John is too.
- (149) a. # John is an uncle and Mary is too.
 b. # Mary is an aunt and John is too.

Bobaljik & Zocca argue that it is part of the lexical semantics that makes this class of nouns different to the *actor/actress* type. There is a true opposition of genders in that *prince* is not underspecified for gender, but rather refers to only males, not females. *Princess* is specified for only females. Thus, for Bobaljik & Zocca, *prince* cannot serve as the antecedent for ellipsis in the same way as *actor* does, since if *princess* is chosen in the elided clause, then there is a parallelism failure, but if *prince* is chosen, it is inconsistent with Mary's gender. Recall, that *actor*, being unspecified for gender is consistent with the feminine gender of Mary. A slightly different, though very similar explanation holds here. We can represent *prince* as in (150) and *princess* (151):

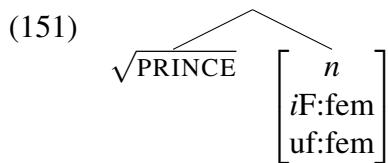
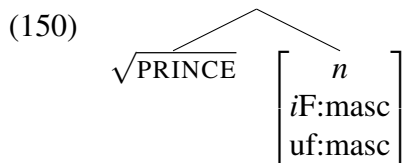

Neither of these structures stands in a containment relation to the other, proper or otherwise, and as such, neither can license ellipsis of the other.

Now we are in a position to return to the quantifier ellipsis discussed above. This reanalysis of the facts in Bobaljik & Zocca (2011) has the benefit that it extends to the quantifier facts from above, in a way that Bobaljik & Zocca's cannot, since that relies on a semantic/pragmatic mechanism that does not apply here. In section 2.2.5, I have claimed that the quantifier *MUCH* carries a number feature that undergoes agreement with the noun that it quantifies over, but remained agnostic as to where that feature is introduced onto the quantifier. Here I propose that it lies on the category defining node that goes with the quantifier. The category defining node of the quantifier I for now I term x . So, the quantifier *much* is actually the following:

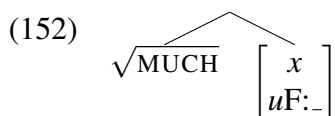

Now, if the quantifier agrees with a plurally marked noun (i.e. the noun carries $uF:plural$), then the uF on the quantifier will also be marked as such, and the quantifier will be spelled out as *many*, as in the following:

(153)

$$\begin{array}{c} \sqrt{\text{MUCH}} \quad \left[\begin{array}{c} x \\ uF:plural \end{array} \right] \end{array}$$

However, fake mass nouns do not carry $uF:\#$, and by assumption, neither do true mass nouns.²³ Thus, the $uF:_$ that lies on x will remain unvalued throughout the derivation. This has the effect that *much* is less specified than *many*, but not vice versa, since *much* is effectively x without a number value, whereas *many* is x with a plural specification. Thus, per (146), *much* can be the antecedent of an elided *many*, but *many* cannot be the antecedent of an elided *much*, accounting for the contrast between (141b) and (142b) above.

2.4.2 Quantifier selection in Purépecha

Whilst it is true that plural mass nouns in English do not suffice as an argument against the morphological approach to quantifier selection, nor are they an argument in favor of it. I now consider evidence from Purépecha, which, whilst supporting the approach taken here that fake-mass nouns are not really mass nouns, also appears to show evidence that quantifier selection is done semantically. The question that will form our main concern is the allomorphy between mass and count quantifiers in Purépecha. All the data are taken from Maldonado (2012) unless otherwise noted.

2.4.2.1 The mass/count distinction in Purépecha

Purépecha is an isolate language spoken in Central Mexico. As Maldonado (2012) outlines, it has a mass/count distinction as English and Telugu does. Plural marking is obligatory for count nouns (154), whilst it is not possible for mass nouns (155):

(154) Taní-mu acháati*(-icha)
 three-MU man-PL
 ‘Three men.’

(155) * yurhri-icha wichu-iri-i-s-ti²⁴
 blood-PL dog-GEN-COP-PFVE-3IND
 INTENDED: ‘This blood (these stains of blood) is the dog’s.’

²³See the discussion below as to why combining a true mass noun - a root that combines with n_{DIV} - is semantically meaningless, and presumably ruled out on grounds of economy.

Similarly, just as in English, count nouns are able to combine with numerals, but mass nouns cannot:

- (156) Taní-mu urhíkwa*(-icha)
 three-MU oak.tree-PL
 ‘Three oak trees.’
- (157) * eshe-s-ka=ni taní-mu yurhirhi.²⁵
 see-PFVE-1/2IND=1SG.SUBJ three-SUM blood
 INTENDED: ‘I saw three (stains of) blood.’

Finally, there is quantifier allomorphy which seems to divide mass versus count nouns: *wánikwa* goes with count nouns whilst *kánikwa* combines with mass nouns, apparently mirroring the distribution of *many* and *much* in English.

- (158) Eróka-sha-p-ka wánikwa/*kánikwa kwirípu-icha-ni.
 wait-IMPV-PST-1/2IND many/much person-PL-OBJ
 ‘I was expecting a lot of people.’
- (159) Churhipu kánikwa/*wánikwa juka-h-i itúkwa-(*icha).
 soup much/many have-PFVE-3IND salt-PL
 ‘The soup has a lot of salt.’

Similarly, mirroring *few* versus *little* in English, there is a similar allomorphy with *namúni-tu* ‘few’, which goes with count nouns, and *sáni-titu*, ‘little’, which goes with mass nouns:

- (160) Jam-sin-di=ksi namúni-tu/*sáni-titu tíndi-cha cosina-rhu.
 be.around-IMPV-3IND=3P.SUBJ few-DIM/little-DIM fly-PL kitchen-LOC
 ‘There are a few flies in the kitchen.’
- (161) Jatsi-ku-Ø sáni-titu/*namúni-tu itúkwa (churípu).
 have-APPL-IMP little-DIM/few-DIM salt soup-obj
 ‘Put a little salt in the soup.’

Thus, in terms of morphosyntax, the mass/count distinction in Purépecha is the same as seen in English and Telugu. As shown in the above examples, there are differences between the two classes in nouns with respect to plural morphology, combination with numerals, and quantifier allomorphy. However, as Maldonado outlines in detail, the mass/count distinction in Purépecha is more than a binary system of mass versus count, but rather it is a tripartite system with a class of nouns that do not fit into either mass or count classes.

²⁴V. Vazquez Rojas Maldonado p.c.

²⁵V. Vazquez Rojas Maldonado p.c.

Significantly for the purposes of this chapter, Maldonado proposes that they are count-mass nouns, or fake mass nouns to use the terminology adopted here.

2.4.3 Nouns that lie in the middle

The nouns that comprise the class of nouns that lie in between mass and count in Purépecha are noted by Maldonado (2012:60) to be a mixture of inanimate entities (man-made objects, edible things) and some animate entities like some birds, fish and lice. These nouns are number neutral, in the sense that without plural marking, they can still refer to pluralities, as in the following sentence, which can mean that the child has either one louse, or multiple lice on his head:

- (162) Indé tatáka sapí juka-htsi-h-ti ambusi(-cha-ni).
 dem man little have-head.LOC-PFVE-3IND louse/lice-PL-OBJ
 ‘The child has a louse/lice on his head.’

Since the plural marking is optional for these nouns, they do not fit neatly into the class of count nouns, where plural marking is obligatory in order to make reference to pluralities. Neither however, do these nouns pattern with mass nouns, since mass nouns are not able to combine with plural morphology. The fact that they are number neutral in a language which does not otherwise tolerate number neutrality appears to position them alongside fake mass nouns in English. Maldonado makes this connection, and analyzes them as being of the same ilk. It should be noted however, that fake mass nouns in Purépecha differ from fake mass nouns in English, since plural marking is never allowed to occur on fake mass nouns in English. For reasons of clarity, I will not refer to them as fake mass nouns, rather, I will refer to them as being ‘middle-class nouns’.

Middle-class nouns in Purépecha are able to combine with numerals, however, unlike count nouns, the plural marker remains obligatory here:

- (163) Taní-mu kurhúcha(-icha).
 three-SUM fish-(PL)
 ‘Three fish.’

Finally, middle-class nouns in Purépecha combine with the count quantifiers *wánikwa* and *namúni-tu*, and not the mass quantifiers *kánikwa* or *sáni-titu*.

- (164) Wíchu wánikwa/*kanikwa jukarha-h-ti tsiri(-icha)
 dog many/much have-PFVE-3IND flea(-PL)
 ‘The dog has a lot of fleas.’

- (165) Í wéshurin=ksĭ namúni-tu/*saní-titu piku-s-ka shaníni(-icha-ni)
 DEM year few-DIM/little-DIM harvest-PFVE-1/2IND corncob(-PL-OBJ)

‘This year I harvested few corncobs.’

Taking stock, we can see the morphosyntax of middle-class nouns in Purépecha paints them very closely to count nouns of the language. This in itself is interesting, since the morphosyntax of fake mass nouns in English, which Maldonado compares them to, makes them seem as though they are mass nouns, not count. However, what is important is that within English, there is a class of nouns that fits neither the class of mass nouns, nor count nouns. This is true in Purépecha since the optionality of plural marking sets fake mass nouns apart from count nouns. However, recall from section 2.2, that I claim that fake mass nouns in English are inherently semantically plural and hence divided. Middle-class nouns in Purépecha fit this criteria in a couple of respects. Firstly, Maldonado shows that even without plural marking, middle-class nouns can license the verbal plural clitic *ksĭ*, which can only be used when the subject is plural. When *ksĭ* appears on the verb and the subject is a middle-class noun as in (166), the subject does not have to be plural marked, but with count nouns, plural morphology must also appear on the subject in order to license the clitic:

- (166) Marisĭ(-icha) wekóri-sha-ti=ksĭ.
 sapodilla(-PL) fall-PROGR-3IND=3PL
 ‘Sapodilla fruit is falling from the tree.’
- (167) Sapí-*(icha) wekóri-sha-ti=ksĭ
 child-PL fall-PROGR-3IND=3PL
 ‘Children are falling to the ground.’

That they are plural is further shown by the fact that they combine with verbs like *estsákurhi*, which require a plural subject, but also one that is divided (mass nouns cannot combine with this verb).

- (168) Shaníni(-icha) estsákurhi-sha-ti.
 corncob(-PL) scatter-PROGR-3IND
 ‘The corncobs are scattering.’

Whether or not this class of nouns really factor into the discussion as being fake mass nouns or not, what is relevant for our purposes here is how they fit in with the quantifier allomorphy in Purépecha. Already noted in (164) and (165) above, these nouns appear with the *count* quantifiers in Purépecha, not the mass quantifiers. Now, there are two

options for how to explain this. Under a flexible roots account, one could posit that these nouns are a special type of count noun in Purépecha, one that does not necessarily need to inflect for plural morphology. This would then, adopting Bale & Barner (2009), mean that the inner structure of these nouns would be as follows:

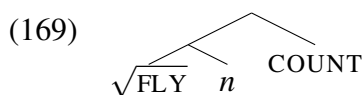

They would then combine with the count quantifiers *wánikwa* and *namúni-tu* by virtue of these quantifiers selecting for, or agreeing with, COUNT.

It is notable that these nouns are seemingly incompatible with what was proposed above for English and Telugu. For those languages, I argued that it was the morphological number that determined the choice of quantifier. In English, *many* and *much* are allomorphs of the same quantifier MUCH, with *many* appearing when the quantifier receives plurality through agreement with the noun it quantifies over. The problem that we face is that in Purépecha, the plurality of the noun is optional, but the quantifier still remains the same.

One way to bring the Purépecha data in line with the approach advocated for above is to assume that the middle-class nouns in Purépecha do carry morphological plurality for the quantifier to agree with, but undergo an optional process of neutralization which deletes the plurality of the noun before pronunciation. Crucially, during the derivation, the fake mass nouns are specified for both morphological and semantic plurality. The quantifiers agree with them, and then the plurality on the noun is optionally neutralized, potentially causing the noun to be realized without the plural suffix.

2.5 The Typology of Inherent Features

As a final part of this chapter, it is worth considering what typology we are left with once we consider all the different combinations of the combinations of heads and features. Note that in what follows, I will assume that heads can only have inherent *i*Fs or inherent *u*Fs, but not both.²⁶ Once we couple this with n_{+DIV} and n_{-DIV} , we are left with eight

²⁶It is not possible to say that literally only a single feature, of whatever type, can be inherent. As shown in Harbour (2007, 2011, 2014), SINGULAR, DUAL and PLURAL are formed by the computation of two number features, [\pm singular] and [\pm augmented]. For the languages under discussion here it makes no difference at least to the morphology, whether we only use one of these features, since only a singular/plural contrast is made in the languages discussed. SINGULAR can correspond to [+singular] and plural to [-singular]. Thus, only one feature is needed to encode the contrast. However, in languages that also distinguish the dual, then [\pm augmented] is important. I do not wish to claim that only singular versus plural can be stored inherently;

combinations. I discuss these eight in turn, and show that four are found, one is impossible, one dubious, one impossible to detect and one is genuinely unaccounted for.

(170)

n_{+DIV}	iF :plural	iF :singular	uF :plural	uF :singular
n_{-DIV}	iF :plural	iF :singular	uF :plural	uF :singular

2.5.1 Divided noun combinations

Firstly, I discuss combinations of features with n_{+DIV} .

(171)

n_{+DIV}	iF :plural	iF :singular	uF :plural	uF :singular
------------	--------------	----------------	--------------	----------------

We have seen two of these combinations already, and since they have been extensively discussed in this chapter, I refrain from further discussion. Firstly, the combination of n_{+DIV} + uF :plural gives *pluralia tantum* nouns. The combination of n_{+DIV} + iF :plural gives fake mass nouns. The combination of n_{+DIV} + uF :singular would give rise to *singulare tantum* nouns - nouns that are inherently morphologically singular but can refer to both singulars and pluralities. *Singulare tantum* nouns are found in Archi (Corbett 2000, Hippisley et al. 2004, Moskal 2015a,b). The forms for ‘mother (of a third person)’ and ‘father’ in the language have only the singular form, but no corresponding plural:

- (172) éjt:ur mother of a third person (ABSOLUTE)
 ábt:u father (ABSOLUTE)

As pointed out by Susi Wurmbrand (p.c), *singulare tantum* would be indistinguishable from fake mass nouns in English, suggesting that it may be possible to conflate the two. If so, then we could restrict the typology further to four combinations, by saying that only uF s could be inherent. I am not aware of any conceptual reason why iF s should not be able to be inherent features, however. Furthermore, as noted above, there are languages (Dutch, and some speakers of English) where fake mass nouns are not countable but *pluralia tantum* nouns are countable. If we treat fake mass nouns as being inherently specified for uF :singular, then we lose a way to account for this discrepancy. Under the approach here, we can make a slight weakening of (73), repeated below in (173) below, in order to account for the difference (174):

- (173) Num⁰ cannot be realized on a lexical item that has an inherent number specification.

this is transparently wrong in Kiowa and Jemez as discussed by Harbour (2007). However, by restricting inherency to iF s or uF s but not both, allows us to capture this. Since I do not discuss languages with dual number, I continue to use the labels singular and plural just as labels, but the reader should bear in mind that I assume the decomposition of number argued for by Harbour.

(174) Num⁰ cannot be realized on the same lexical item as an inherent *iF:#* specification.

(173) characterizes languages where neither fake mass nouns nor *pluralia tantum* nouns can be counted. (174) captures languages where the latter can be counted, but not the former.²⁷

The final combination in (171) that we predict is a combination of $n_{+DIV} + iF:singular$. This would be a noun with divided interpretation, that could exclusively refer to singulars. I do not know of such a noun, and leave it here as an open contention.

In summary, three of the four combinations are seen: *pluralia tantum*, *singulare tantum* and furniture nouns all exhibit types of nouns that are divided, yet have inherent number. It remains to be seen whether the final type - nouns that refer semantically exclusively to singulars - is found.

2.5.2 Non-divided noun combinations

In this section I discuss combinations with n_{-DIV} .

(175)

n_{+DIV}	$iF:plural$	$iF:singular$	$uF:plural$	$uF:singular$
------------	-------------	---------------	-------------	---------------

We have already seen the combination of $n_{-DIV} + uF:plural$ this chapter, with Telugu *niiLLu* and *paalu*, thus I refrain from further discussion of this combination.

With regard to the other combinations, I believe that they divide into two types. The first type is impossible, since the combination of n_{-DIV} with $iF:singular$ is semantically uninterpretable. The remaining two combinations are semantically possible, but are extremely difficult to detect in a language, casting doubt upon their learnability.

We can discount cell 2 in (175), where n_{-DIV} combines with $iF:singular$, since there is an incompatibility in interpretation between n_{-DIV} and $iF:singular$. Recall that n_{-DIV} yields an undivided lattice; a lattice that no matter what part of it you pick out, there will always be a subpart of that lattice which also satisfies the predicate. However, adopting the semantics of number given in Harbour (2007, 2011), ‘singular’ is defined in the following way:

(176) $[+singular] = \lambda x[atom(x)]$

Atoms are by definition only possible with a divided interpretation. There are the parts of a predicate that can be divided no further. Thus, trying to combine with n_{-DIV} and $iF:singular$ yields an incompatibility, and I will assume that it is uninterpretable.

This leaves us with cells 1 and 4. I believe that both of these types, whilst possible, are not found as inherent specifications. With regard to cell 1, the combination of n_{-DIV}

²⁷As mentioned earlier, we might expect languages that can count fake mass nouns but not *pluralia tantum* nouns. I am not aware of such a language.

+ *iF*:plural, this yields a combination indistinguishable from regular mass nouns. ‘Plural’, under the assumptions of number made here, refers to the feature combination of [-singular], [+augmented]. Combining the predicate first with [-singular] simply means that the output is not an atom, which is desirable here given that undivided lattices cannot be atoms. [+augmented] is defined in the following way (Harbour 2011):

$$(177) \quad [+augmented] = \lambda P . \lambda x : P(x) . \exists y [P(y) \wedge y \sqsubset x]$$

This essentially ensures that x satisfies the predicate, and always contains a smaller subpart y that also satisfies the predicate. However, this is necessary for an undivided extension as well, which is defined as being able to take any part of the lattice and there always being a subpart of it which satisfies the predicate. There is however, nothing in [+augmented] which forces the predicate to be interpreted as if it divided however. In fact, plurals and mass nouns are well known to be interpreted in similar ways, see Chierchia (1998). So, whilst [+augmented] is not incompatible in the same way that [+singular] is, it does not impose any further restrictions on a undivided noun. This is important, considering the final cell in (175). This combination, a noun that is interpreted as undivided with plural ([-singular,+augmented]) interpretation, is in fact indistinguishable as far as I can tell from regular mass nouns.²⁸

The final combination is $n_{-DIV} + uF$ singular. Again, I believe that this is a potential combination, but it is hard to find. Mass nouns overwhelmingly appear with singular morphology, and very rarely (unless coerced into count usage) combine with plural morphology. Thus, a noun with undivided interpretation but obligatory singular morphology will again be indistinguishable from other mass nouns in a language. There are languages such as Greek (Tsoulas 2007) and Halkomelem Salish (Wiltschko 2008) where mass nouns combine with plural morphology, so we could potentially find a mass noun that refuses to combine with plural morphology. However, in Greek, Tsoulas notes that only a subclass of mass nouns (substance mass nouns) combine with plural morphology. A language needs to found where all mass nouns can become plural, in order to explain the outliers that do not as being inherently singular. I suspect that this type of language, though possible, would be extremely rare, making detection of the class difficult.

To sum up, we have seen that n_{-DIV} combines less freely with inherent features than n_{+DIV} . Whilst we can, and have, found the combination $n_{-DIV} + uF$:plural in Telugu, the singular counterpart to this noun is extremely unlikely to be found on account of the rarity of languages that allow for free combination of plural morphology with mass nouns. With

²⁸ There are plural mass nouns, that give rise to an abundance reading (Tsoulas 2007, Wiltschko 2008), however, I assume that this is more of a pragmatic effect, and would never give rise to an inherent specification.

regard to *iF*s combining with n_{-DIV} , *iF:singular* is not possible due to semantic incompatibility, and combination of n_{-DIV} with *iF:plural* yields a configuration indistinguishable from other mass nouns.

(178)

n_{+DIV}	<i>iF:plural</i>	<i>iF:singular</i>	<i>uF:plural</i>	<i>uF:singular</i>
	Fake mass	Predicted	<i>Pluralia tantum</i>	<i>Singulare tantum</i>
n_{-DIV}	<i>iF:plural</i>	<i>iF:singular</i>	<i>uF:plural</i>	<i>uF:singular</i>
	?? ²⁹	Impossible	Telugu	??

2.6 Conclusions

In this chapter, I have shown that the proposal that features are decomposed into two distinct halves gives us a new window into the nature of the mass/count distinction, specifically a new way of looking at the nature of nouns which seem to lie some way in between mass nouns and count nouns. In both English and Telugu, I showed that there are nouns that have the morphosyntax of being either mass or count, but the semantics of the opposite value. For Telugu, we saw nouns that have the semantics of being mass nouns, but the morphosyntax that count nouns in the language have. The opposite case was seen in English, whereby nouns which have count semantics have the morphosyntax of mass nouns. The overarching conclusion that was drawn was that these janus like nouns result from having different specifications for their number feature. The relevant nouns in Telugu were inherently specified as being [*uF:plural*], but lacked a value for the *iF* part of the number feature. In English, fake mass nouns were analyzed as nouns which were inherently specified for [*iF:plural*], but did not receive a *uF* value for number.

I also discussed a number of secondary issues in this chapter that resulted from this, such as how inherent number plays a spoiling role in English, as well as the distinction between mass and count quantifiers that is often seen in the mass/count distinction.

²⁹?? indicates that this combination would be extremely difficult to detect in a language.

Chapter 3

The Structure of Semantic Agreement

Having outlined the proposal that grammatical features are split into two distinct halves in chapter 1, and shown how it offers a new perspective on the mass/count distinction in chapter 2, I now move on to discuss how the grammar manipulates these distinct types of features. Specifically, in this chapter I focus on the nature of agreement, and show that agreement most often targets *u*Fs, however certain languages allow for agreement to target the *i*F value of a feature. The key conclusion that will be drawn is that agreement that targets an *i*F is a different process than one that targets a *u*F, thereby supporting the fact that *i*Fs and *u*Fs are distinct entities. The data in this section will come primarily from two case studies in semantic agreement: (i) agreement with collective nouns in British English; and (ii) agreement with Quantified Noun Phrases (QNPs) in Russian.

3.1 Semantic Agreement

Semantic Agreement is the phenomenon whereby, in instances where we can distinguish between the two, agreement tracks the semantic specification of the noun rather than the morphology. Below, I will concentrate on two phenomena where we can see that agreement is sensitive to the semantics of the noun, but not the morphology. The first will be collective nouns (CNPs) like *committee*, *government* in certain dialects of English, which although morphologically singular, can control plural agreement, reflecting the fact that CNPs denote pluralities of members.

(179) The committee are drawing up a proposal right now.

Corbett (1979) discusses CNPs, in order to motivate the Agreement Hierarchy that will be the central topic of chapter 4. The second part of the investigation will be QNPs in

Russian, although seeing that these reflect semantic agreement is more complicated and I postpone discussion of this until section 3.6 below.

In order to ensure that we are dealing with agreement targeting the *iF* as opposed to the *uF*, we must be dealing with a situation where the morphology and semantics can be distinguished from each other. If not, we would not be able to tell what was controlling the agreement on the target; it could be either the morphology or the semantics. There are instances where this is possible. CNPs are one area where we see semantically motivated agreement, not just from English, but Corbett (2000) notes that similar facts are seen in Spanish, Old Church Slavonic, Paumari, Kabardian and Samoan.

A second place where semantically motivated agreement is seen is with polite pronouns. In various languages, in order to express politeness or respect, a different pronoun is used where we might otherwise expect 2nd person singular. In the following, from French (Wechsler & Hahm 2011), the referent of the pronoun is a single addressee (indicated by the agreement on the adjective), but the form of the pronoun is plural, which is indicated by the agreement on the verb:

- (180) Vous êtes loyal
 you.PL be.2.PL loyal.M.SG
 ‘You (one formal male addressee) are loyal.’

Semantic agreement has attracted a rather scant amount of attention in the minimalist literature, but is more widely discussed in other frameworks, such as HPSG (Pollard & Sag 1994, Wechsler & Zlatić 2000, 2003), and LFG (Hahm 2010, Wechsler & Hahm 2011).

Wechsler & Zlatić (2003) formulate an approach to agreement that specifically takes into account semantic agreement. Their approach is formulated in HPSG terms. For them, agreement features come in various types which reflect a flow of information between the morphological shape of the noun and its semantics. At the left edge is the declension information of the noun, reflecting its morphology, and at the right edge lie the semantic information of the noun. Between these two lie CONCORD and INDEX features, which are the features used in determining agreement values. In the usual case, these all have the same value.

- (181) DECLENSION — CONCORD — INDEX — SEMANTICS

However, it is possible for there to be a disruption in this system. Supposing that the declension class of a noun does not match its semantics, then there will be competing values along the system. For instance, the flow could be broken between index and concord:

- (182) DECLENSION — CONCORD -/- INDEX — SEMANTICS

In their system, what I have been calling semantic agreement corresponds to one of a few options. In the following, we can say that the auxiliary and participle verb undergo semantic agreement, since they reflect the plural nature of the head noun *deca* ‘children’, yet the morphology of the noun is reflected in the NP-internal agreement, which is feminine singular. This situation arises from the mismatch between CONCORD and INDEX in (182). *Deca* has a mismatch where the values of SEMANTICS and INDEX are plural, whilst DECLENSION and CONCORD are singular. Verbs agree with the INDEX value of the noun, whilst NP-internal elements agree with the CONCORD feature, which produces the effect whereby a noun of one gender and number can control both morphologically and semantically motivated agreements.

- (183) Ta dobra deca su doš-l-a
 that.F.SG good.F.SG children AUX.3PL come-PPRT-N.PL
 ‘Those good children came.’

For Wechsler & Zlatić, it is also possible for INDEX to mismatch from SEMANTICS, which happens with nouns like *sentinelle* ‘sentry’ in French, which can refer to either a female or male, but exclusively takes feminine agreement, across all targets. For Wechsler & Zlatić, this represents a disruption between DECLENSION, CONCORD and INDEX, which are all feminine, and SEMANTICS, which in the relevant case would be masculine (relevant being such that we can discover a mismatch between morphology and semantics).

- (184) La sentinelle a été prise en otage.
 the.F sentry has been taken.F hostage
 ‘The (male or female) sentry was taken hostage.’

There is also mismatches between DECLENSION and CONCORD, however since they are not directly relevant to the topic at hand, so I do not discuss them further.

3.2 Semantic agreement in British English

Certain English dialects allow for variability in what agreement value for number is chosen when the controller of agreement is a CNP like *government*, *committee* or *team*. These nouns standardly show singular agreement in all dialects of English, but certain dialects additionally allow plural agreement with these nouns. There is substantial variation across the dialects of English as to how open each dialect is to showing plural agreement with CNPs, an issue to which I will return in chapter 4. In a corpus study, Levin (2001) shows British English to be the most open to plural agreement, with American English the least open, and Australian English somewhere in between.

3.2.1 Singular versus plural agreement with CNPs

The variation in agreement can be seen in the following two sentences. All dialects of English allow (185a), but only certain dialects freely allow (185b).¹

- (185) a. The government **is** trying to counter the domestic threat from ISIS.
 b. %The government **are** trying to counter the domestic threat from ISIS.

Restricting our attention only to dialects which allow (185b), we can see that the ability to license plural agreement is not limited to just one or two CNPs, nor only to auxiliary agreement, but this is a general property of CNPs in these dialects. In (186) we can see that both anaphors and pronouns can alternate between singular and plural agreement:

- (186) a. The faculty nominated **each other** for Nobel Prizes.
 b. The team gave **itself** a goal of February for getting to the top of league.
 c. This parliament is corrupt. **They** are nothing but crooks.
 d. The committee is not making decisions right now. **It** will meet again next quarter.

Interestingly however, plural agreement is not in absolute free variation with singular agreement. As noted in various places (Corbett 1979, Elbourne 1999), for dialects which allow plural agreement, plural agreement is only allowed in a subset of the environments where singular agreement is allowed. Corbett (1979) notes that plural agreement is not allowed on demonstratives, with Elbourne (1999) further noting that this is the case even when plural agreement is shown on the auxiliary (*cf.* (187b)):²

- (187) a. ***These** committee sat late.
 b. **This**/***these** set are all odd.

Plural agreement is also restricted in other environments, notably environments where one might expect it to be allowed. As shown above in (185b) and (187b), plural agreement

¹Anticipating the discussion in chapter 4, it should be pointed out that not all mismatches between two elements are allowed. For instance, (i) is ungrammatical:

- (i) *The government always try to do its best.

Which mismatches are allowed and which are disallowed will be the focus of chapter 4, and I postpone discussion until then.

²As to why demonstratives do not allow for plural agreement, it seems like it is an idiosyncratic property of English that demonstratives do not allow for semantic agreement. In the context of this dissertation, they are not licit *iF* targets. I discuss this further in section 4.5.2.

is perfectly acceptable on auxiliary verbs. However, if the CNP is controlling agreement in an existential *there*-construction, plural agreement is not allowed, as noted by Elbourne (1999):

- (188) a. There is a committee deciding the budget for next year.
 b. *There are a committee deciding the budget for next year.

Plural agreement is otherwise fine in existential constructions of English, so the fact that plural agreement is not available in (188b) is of genuine interest:

- (189) There are three dogs in the garden.

Elbourne (1999) notes another discrepancy between singular and plural agreement with CNPs. As can be seen in the following raising constructions, when a CNP controls singular agreement in the higher clause, it is able to reconstruct into the lower clause. However, when the CNP controls plural agreement in the higher clause, reconstruction is not allowed:

- (190) a. A northern team is likely to be in the final. $\exists \gg$ likely / likely $\gg \exists$
 b. A northern team are likely to be in the final. $\exists \gg$ likely / *likely $\gg \exists$

Again, as shown in (190a), CNPs are in principle able to reconstruct for scope, therefore the inability of the CNP to reconstruct in (190b) is related to the fact that it controls plural agreement.

A final difference between plural and singular agreement is noted by den Dikken (2001), who shows that a potential ambiguity in predicate constructions is missing when the CNP controls plural agreement. When the CNP fills the subject position of a predicate construction, and controls singular agreement, (191a), the sentence is ambiguous between what den Dikken calls the subject reading and the predicate reading. The two readings are paraphrased in (192) below, but the difference between the two readings is that in the predicate reading, the referents of *they* are necessarily part of the committee, whilst in the subject reading, *they* are the owners/heads of the committee, without necessarily being a part of it. As can be seen in (191a), both readings are available when the agreement is singular, but when it is plural as in (191b), the predicate reading is not available:

- (191) a. The best committee is theirs. committee = ✓ subject / ✓ predicate.
 b. The best committee are theirs. committee = ✓ subject / ✗ predicate

- (192) a. The best committee belongs to them. (subject reading)
 b. The committee that they belong to is the best committee. (predicate reading)

In sum then, CNPs in certain dialects of English are able to control either singular or plural agreement, but in those dialects, plural agreement is only allowed in a subset of environments where singular agreement is allowed.

3.2.2 Part 1: Where plural agreement is (dis)allowed

One could go in two ways to explain why plural agreement is more restricted than singular agreement, and both ways have been appealed to in the existing literature on the phenomenon. I provide a full comparison between my approach, and various existing approaches in section 3.4.2 below. The first approach, which I will call the *difference-approach* posits that singular-agreeing CNPs and plural-agreeing CNPs are different in some manner, and the difference between the two prevents plural-agreeing CNPs from appearing in certain environments. Essentially, the argument is that a CNP that controls plural agreement is barred from certain configurations, and so plural agreement is more restricted. The second approach, which I will term the *structural approach*, argues that there is nothing special about plural-agreeing CNPs, but that plural agreement is disallowed it is because the CNP has found itself in a position where the feature that carries plural cannot be targeted for agreement. This approach crucially does not prevent a plural-agreeing CNP from appearing in a certain position (in fact there is no singular- versus plural-agreeing CNPs), but rather certain configurations do not allow the plural value of the CNP to be accessed.

Essentially the difference between the two approaches is whether CNPs have more than one lexical item. My analysis will follow the structural approach, and will argue that the descriptive generalization in (193) determines the distribution of plural agreement with CNPs.

(193) LF-visibility (descriptive generalization)

With CNPs, plural agreement requires the controller to c-command the target at LF, but singular agreement does not.³

Before explaining why it is that LF-visibility should hold, it serves to really show that it does. Firstly, in a simple sentence where the CNP is the subject of the sentence like in (194), the CNP will lie in Spec,TP, under standard assumptions.⁴

(194) The team is/are winning the game.

³I differ from Corbett here in using agreement in a more restricted sense, assuming that pronominal agreement is not the same process that gives rise to verbal agreement.

⁴In all the trees, I use BE in capital letters to signal the position of the auxiliary verb, which undergoes agreement.

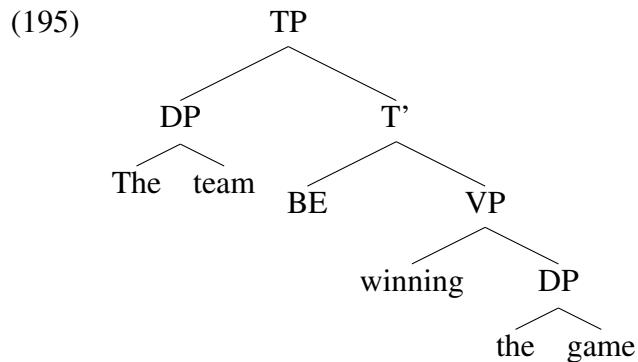

In (195), we can see that the CNP lies above the auxiliary, and in accordance with (193), both singular and plural agreement are allowed.

Shifting attention to where plural agreement is not licensed, I now turn to existential constructions, which, recall from (239) above, when CNPs are in the associate position, these constructions allow for singular agreement but not plural. Existential constructions in English have attracted a wide variety of approaches in the literature (see Chomsky 1995, Lasnik 1995, Bošković 1997, Bobaljik 2002, Hazout 2004, Witkós 2004 amongst many others), and there exists no clear consensus on what approach is correct. I do not attempt to offer an analysis of the construction here, since it would take us too far from the topic at hand, however one point which is pertinent to the discussion is the position which the associate DP holds in the structure. Some approaches take it that the associate at some point in the derivation moves into Spec,TP to be Case licensed. Chomsky (1995) proposes that this movement takes place at LF, where it adjoins to *there*. This movement is motivated by the need to check its Case features, since its original position does not allow it to do so (see Lasnik 1995 however for discussion).

For different reasons, both Lasnik (1995) and Bobaljik (2002) propose that the associate of an existential construction moves into the higher position at some point in the derivation. Contrasted against these are approaches where the associate stays low throughout the derivation. Approaches of this type are Bošković (1997) and Witkós (2004), where it is assumed that *there* and the associate are somehow related, and *there* either moves down covertly (Bošković) to adjoin to the associate, or they begin life together and *there* moves away (Witkós). The crucial test for distinguishing the two types of approaches is whether we can find any evidence that the associate does move into Spec,TP at some stage in the derivation. As den Dikken (1995) points out, the evidence suggests that it does not:

- (196)
- a. Some applicants_{*i*} seem to each other_{*i*} to be eligible for the job.
 - b. *There seem to each other_{*i*} to be some applicants_{*i*} eligible for the job.
 - c. Someone_{*i*} seems to his_{*i*} mother to be eligible for the job.

- d. *There seems to his_i mother to be someone_i eligible for the job.

These facts suggest that the associates in existential constructions remain low in the structure at all levels of representation, and never in fact raise to Spec,TP. Thus, I will assume that in existential constructions, the associate remains low in the structure and never raises as high as Spec,TP.

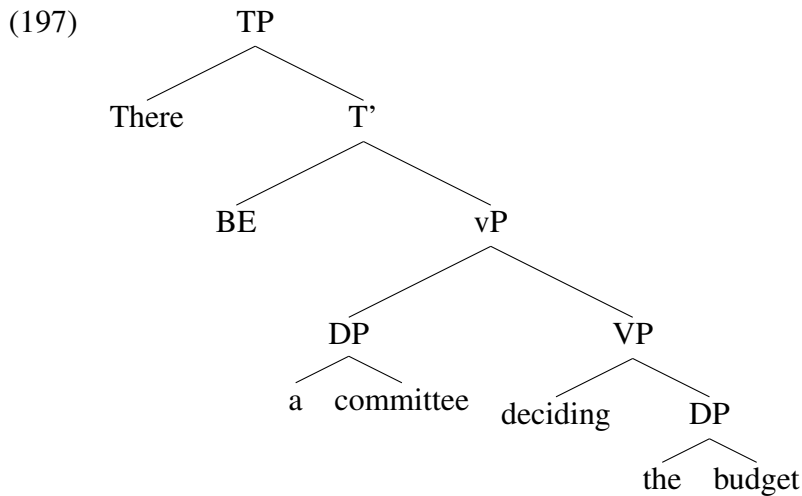

In (197), *a committee* remains in situ in Spec,vP, remaining low in the structure beneath T.

Similarly, as in (190) above, repeated in (198), plural agreement is not possible when the CNP reconstructs for scope, whereas when the CNP is interpreted in the higher clause, both singular and plural agreement is possible:

- (198) a. A northern team is likely to be in the final. ∃ >> likely / likely >> ∃
 b. A northern team are likely to be in the final. ∃ >> likely / *likely >> ∃

For raising sentences, I follow Fox (1999) who proposes that a reconstructed reading arises when there is a mismatch between the place where a DP is positioned in the surface form of a sentence, and the position where it is interpreted. Therefore, when the CNP reconstructs into the lower clause, the position of interpretation is in the lower clause, whereas the position of pronunciation is in the higher clause.

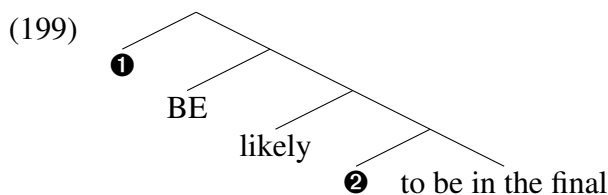

The difference between the reconstructed readings of (198a) and (198b) is where the semantically interpreted copy is. When it reconstructs, it lies beneath T, but above it when it does not reconstruct. Thus in the reconstructed reading, the CNP lies in position ② at LF, whereas in the non-reconstructed reading, the CNP lies in position ①. Thus, in accordance with *LF-visibility*, plural agreement is licensed when the CNP does not reconstruct, but not licensed when it does.

The final difference between singular and plural agreement comes from predicate constructions, as identified by den Dikken (2001). The relevant examples and readings are repeated below:

- (200) a. The best committee is theirs. committee = ✓ subject / ✓ predicate.
 b. The best committee are theirs. committee = ✓ subject / ✗ predicate
- (201) a. The best committee belongs to them. (subject reading)
 b. The committee that they belong to is the best committee. (predicate reading)

In order to understand why plural agreement disallows the predicate reading, we must understand the difference in structure between the subject and the predicate reading. For the subject reading, I assume that the structure is as follows:

(202)

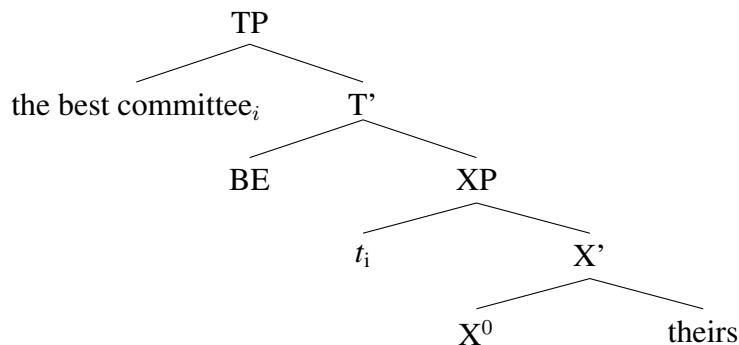

In (202), the subject *the best committee* has raised from its base generated position into Spec,TP. The position where the CNP is base generated is the subject position of the predicate XP (see den Dikken 2007). By way of contrast, the structure that gives the predicate reading has the CNP raise from the predicate position in the predicate XP as follows:

(203)

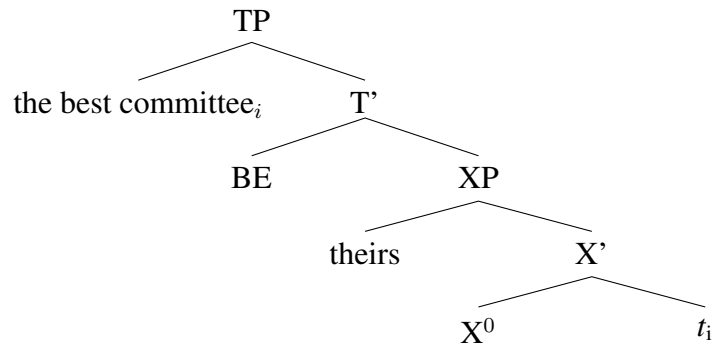

The differences between the subject and the predicate reading of the sentences is where the CNP starts out. In both structures, *the best committee* is pronounced in Spec,TP, but the difference is that this noun phrase plays the role of the predicate for the predicate reading, but not in the subject reading. This distinction is important in light of the findings by Heycock (1995), who argues that predicates must always reconstruct into their base position at LF, based in part on the following (Heycock 1995, p546):

(204) * [How proud of John_i]_k do you think he_i is t_k?

Taking this to be the case, then we can see that *at LF*, the two structures are the following:

(205) *Subject reading at LF*

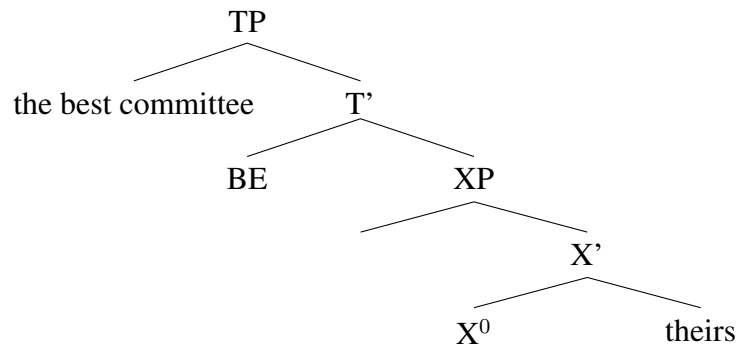

(206) *Predicate reading at LF*

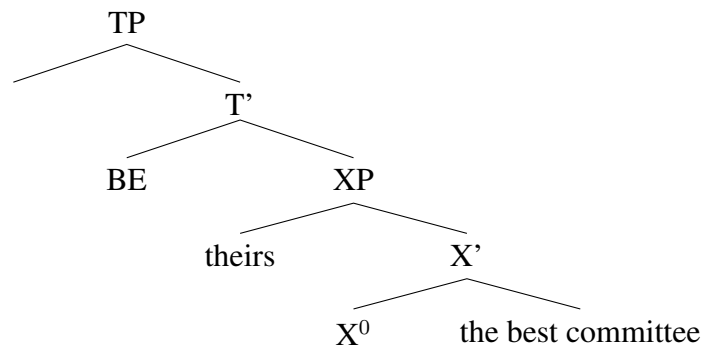

In both of these instances *the best committee* is the controller of agreement; den Dikken (2007) shows that with predicate constructions in English, it is always the element that lies in Spec,TP that is the controller of agreement, irrespective of whether it is a regular structure, or an inversion structure where the predicate raises there. Now we can see why plural agreement is not allowed in the predicate readings. In accordance with *LF-visibility*, plural agreement is not possible in the predicate reading because the controller of agreement, *the best committee*, which is the reconstructed predicate, lies underneath the target, T^0 , at LF.

3.2.3 Part 2: *i*Fs are targeted differently than *u*Fs

My proposal to explain why plural agreement is more restricted than singular agreement lies in recognizing that singular agreement is different than plural agreement. In this dissertation I make a distinction between features that are interpreted by the semantic component, *i*Fs, and features that are interpreted by the morphological component, *u*Fs. However, I will show that each of these cannot be targeted in agreement in the same manner. Semantic Agreement (where agreement targets the *i*F) obeys a different set of structural rules than Morphological Agreement (targeting the *u*F). CNPs involve a divergence of number information on the CNP, its *i*F is plural but its *u*F is singular. Singular agreement from a CNP is agreement targeting the *u*F value of the CNP, whereas plural agreement is agreement targeting the *i*F value of the CNP. The reason why plural agreement is more restricted is that *i*Fs can only be targeted under a more specific set of circumstances than *u*Fs. In essence, the reason why plural agreement is more restricted than singular agreement is because the environments where *i*Fs can be targeted (and so plural agreement shown) form a subset of the environments where *u*Fs (singular agreement) can be targeted.

The first part of the analysis is how number is represented in CNPs. Since number is the only relevant value here, I will stick to this. As mentioned above, I assume that there is a divergence in the number value between *i*F and *u*F in the number information carried by

CNPs: they have uF :singular, but iF :plural. The morphological uF is specified as singular, explaining why even when plural agreement is controlled by these nouns, the form of the CNP remains singular.⁵

(207) $\phi_{number} = [uF:singular, iF:plural]$

That the uF value of a CNP is singular is obvious, since they are transparently morphologically singular. However, that they are semantically plural is less obvious, since the intuition is that they denote a single instance of the CNP. In fact, CNPs are somewhat of a hybrid between being singular and plural. Whilst true that the DP *a committee* denotes a single committee, committees are (generally) not made up of a single individual. We can however see that CNPs are semantically plural given that they are able to combine with predicates that require a referent that is semantically plural, like *gather*.

- (208) a. The owls gathered on a branch.
 b. #The owl gathered on a branch.
 c. #I had a nightmare that some scissors came alive and gathered to attack me last night.⁶

As shown in the contrast between (208a) and (208b) *gather* is licensed when the subject is plural. However, the infelicity of (208c), with a *pluralia tantum* noun shows that morphological plurality is irrelevant in determining whether *gather* is licensed, but it must be the semantic value.⁷ As can be seen below, CNPs happily combine with *gather*, even when the agreement is singular (209b), showing their semantic plurality:

- (209) a. The government gathered to debate the measure.
 b. The government is gathering to debate the measure.

There remains a question of if CNPs are semantically plural, how they come to be interpreted as a singular. One option is that the semantic value of a CNP is allowed to vary

⁵Note that I assume the representation in (207) is only for *singular* CNPs, not plural. Plural CNPs uniformly trigger plural agreement, with their referents uniformly multiple CNPs. Thus, their feature specification for number is clearly $\phi_{number} = [uF:plural, iF:plural]$. Since the numbers match, it is impossible to tell where any agreement value has come from, and so these nouns do not hold any interest for the current purpose.

⁶This is infelicitous when referring to a single pair of scissors.

⁷Mass nouns in fact license *gather* whilst being morphologically singular. However, one might not want to call mass nouns 'plural' in reference. The licensing of *gather* is then likely restricted to non-atomic predicates, which encompasses both mass nouns and plurals. However, all that is crucially relevant for our purposes is motivating the assumption that CNPs are not semantically singular to match up with their morphological value, so I abstract away from this issue, and flippantly use the singular-versus-plural criterion for licensing *gather*.

between being plural and singular in case the μF value is singular. That is, there would in effect be two lexical variants for CNPs, one semantically singular, one semantically plural.⁸ This is supported by consideration of predicates that must apply to singulars. Schwarzschild (1996) shows that a bunch meaning is not entirely equivalent to a plurality meaning. Thus, although *a deck* refers to a group of cards, we get the following contrast:

- (210) a. The deck has two aces in it.
 b. ?The cards have two aces in them/it.
- (211) a. # The deck has two aces among it/them.
 b. The cards have two aces among them.

Deck is not a CNP in English - it never licenses plural agreement so I leave it aside here.⁹ However, one can analyse the above contrast as being the result of needing a plural or singular subject, which alternates according to whether *in* or *among* is used. The former requires the subject to be singular, whilst the latter requires a plural subject. Now, if CNPs have two entries, one singular and one plural, then we expect them to happily combine in both, which is borne out:¹⁰

- (212) a. The team has two strikers in it.

⁸One option is that there is a semantic operation that converts a plurality to a singular along the lines of that proposed by Chierchia (1998).

⁹Its semantics puts it close to being a CNP, since it is a whole unit consisting of individual members. Yet, as mentioned, it does not pattern like true CNPs. The question becomes where the cut-off point is. One option, as Schwarzschild (1996) points out, is that for agreement to alternate between plural and singular, animacy of members is necessary. So, relevant for current purposes, only the class of animate collectives are allowed to vary between iF :plural and iF :singular. Whether animacy is the right restriction or not remains to be seen. Work by Corbett points out that cross-linguistically, it does not seem to be the case that insects are treated as animate entities (J. Bobaljik, p.c.). However, CNPs that refer to insects such as *colony* seem to license plural agreement well enough:

- (i) The colony are dying.

I leave this matter open for now, and hope that future research bears on the question.

¹⁰As will be discussed below, other authors (den Dikken 2001, Sauerland 2004a,b) have argued that there are two different variants of CNPs - one that licenses singular agreement and one that licenses plural agreement, and that the restrictions on plural agreement can be derived from which variant is allowed in which configuration. It is important to stress that I am not making this proposal. I assume that aside from the feature specifications, CNPs with iF :plural and those with iF :singular are equivalent, and are allowed to appear in the same syntactic environments, but that an agreement that targets iF :plural is not always possible under certain circumstances. As pointed out below, the type of approach taken by both den Dikken and Sauerland makes empirically wrong predictions, for instance in the case of existential constructions, where plural agreeing CNPs must be licensed. It bears repeating then that in my approach, singular agreement does not necessarily imply that the CNP root has combined with iF :singular. Rather it could have combined with iF :plural, but the μF :singular is used for agreement.

- b. The team have two strikers amongst them.

With CNPs analyzed in this manner, as involving a split between the morphological and semantic values of the number feature, what underlies *LF-visibility* becomes clearer. *LF-visibility* is a descriptive generalization that states when plural agreement is and is not licensed.

(213) LF-visibility (descriptive generalization)

With CNPs, plural agreement requires the controller to c-command the target at LF, but singular agreement does not.

We can rephrase *LF-visibility* as follows:

(214) LF-visibility (revised)

With CNPs, agreement with the *iF* requires the controller to c-command the target at LF, but agreement with the *uF* does not.

In section 3.3.2, I will return to show why this pattern holds, namely why *iF* agreement requires c-command at LF, however, I must lay some groundwork into the nature of Agree.

3.3 Excursus: The mechanism of Agree

The crucial difference is that *iFs* can only be targeted if the target is looking upwards in the structure, whilst *uFs* do not face this restriction. The question is how to capture this difference between semantically motivated and morphologically motivated agreement. Splitting features into *iFs* and *uFs* allows us a way to capture why these agreement types should differ: all that is needed is to understand why *iFs* require upwards c-command.

I propose that we can understand these facts in terms of where agreement happens. Features are split into two halves, which at spell-out are split and sent to the LF and PF interfaces. Assuming an inverted T-model of the grammar (see Bobaljik 1995) and late insertion of elements (Distributed Morphology, Halle & Marantz 1993), both *uFs* and *iFs* enter the derivation and are present in the syntactic component. At the point of transfer to the interfaces, *iFs* are sent to LF, where they are interpreted by the semantic component. *uFs* on the other hand, are sent to PF, where they are manipulated by the morphological component, and eventually replaced by phonological exponents. This means that during the derivation, both *iFs* and *uFs* are present during the syntax. In the morphological component, only *uFs* are present, whereas in the semantic component, only *iFs* are present.

(215)

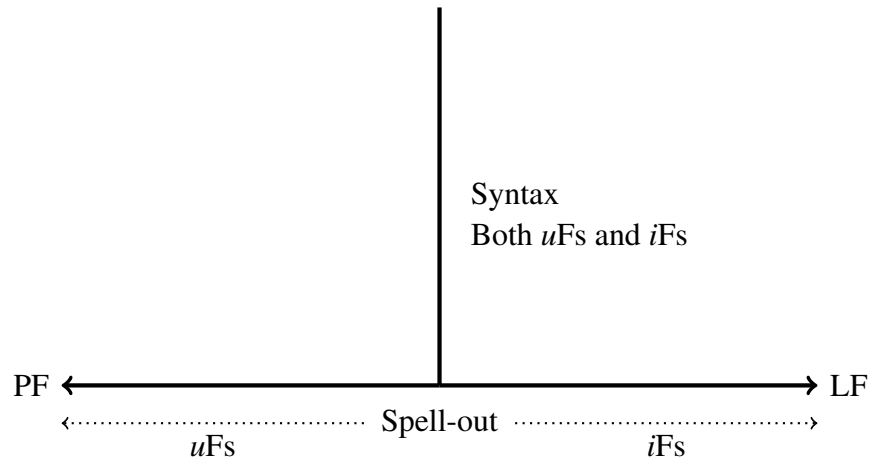

This is relevant, because it cross cuts with two prominent debates within a GB/Minimalist approach relating to the nature of agreement. The first debate concerns where agreement should take place. On the one hand are those that argue that agreement should be seen as a purely syntactic phenomena that takes place exclusively in the narrow syntax (see for instance Chomsky 2000, 2001, van Koppen 2005, Bošković 2009b, Preminger 2011 among many others), whilst on the other hand are proposals that agreement takes place exclusively post-syntactically (Bobaljik 2008). A third view holds that agreement is distributed across the narrow syntax and the PF branch (Arregi & Nevins 2012, Bhatt & Walkow 2013).

3.3.1 Directionality of Agree: A brief overview

Connected to this debate, is what can agreement see and what can it not see. That is, supposing that agreement is the result of some operation AGREE (Chomsky 2000), which is essentially an operation of transferring a value of one feature to another, then how does AGREE work? Here there are various competing proposals taking into account direction, feature types, activation and various other considerations. What I will focus on here is the directionality of AGREE. Chomsky (2000, 2001) proposes that AGREE works in the following configuration:¹¹

(216) *Downwards Agree*

¹¹I avoid using the shortened form *u*F here, which is commonly used in the minimalist literature, to avoid confusion with the terminology adopted here.

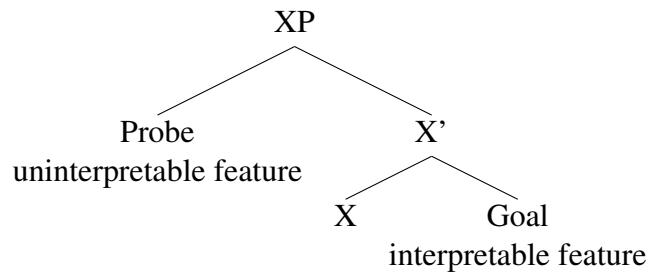

Agreement works in (216) in the following way. The Probe contains an *uninterpretable* feature which must be checked in order to avoid crashing the derivation.¹² In order to be checked, it must find a matching *interpretable* feature with which it can enter a relation with, i.e. the goal. The goal must be local to the probe, and there cannot be any other potential goals intervening in the structure. What is crucial in this model is that the probe looks downwards in the structure: the probe must c-command the goal. There are various reasons why the c-command requirement should hold in this way. Firstly, AGREE, in Chomsky's original formulation was inextricably linked with the EPP, and served the function of allowing an element to move from one position to another. Agreement facilitated movement of an element to the specifier of the probe, and since movement goes upwards in the tree, the probe must look downwards in the structure.

Aside from linking the operation of AGREE to movement, there appear to be cases where agreement unquestionably looks downwards. One such instance is where T shows agreement not with the subject of a sentence as expected, but with the object. This is famously shown in Icelandic by Zaenen et al. (1985), where, in the following, T agrees with the Nominative object instead of the Dative subject:

- (217) Um veturinn voru konunginum gefnar ambáttir. [Icelandic]
 In the.winter were.PL the.king.DAT given slaves.NOM
 In the winter, the king was given (female) slaves.

Another instance where agreement can be seen to be looking downwards comes from long-distance agreement, where a verb agrees with an element in a lower clause. Polinsky & Potsdam (2001) give the data in (218), where the matrix verb shows class III agreement with the object of the embedded clause:

- (218) enir užē magalu bāc'rufi b-iyxo [Tsez]
 mother boy bread.III.ABS ate III-know
 'The mother knows the boy ate the bread.'

¹²Recall from chapter 1 that the terms *uninterpretable* and *interpretable* mean (subtly) different things from how I am using them.

Polinsky & Potsdam propose that the embedded object remains in the embedded clause, albeit it in the left periphery¹³. Crucially, they show that a specifier-head configuration is not a possible analysis to explain the agreement in (218), therefore, the agreement is downwards looking (but see Chandra 2007 for an different view).

Contrasted against these approaches are approaches where agreement does not look downwards in the tree, but rather looks upwards, for instance Zeijlstra (2012) and Wurmbrand (2012b). In these instances, the relevant configuration is as follows:

(219) *Reverse Agree*

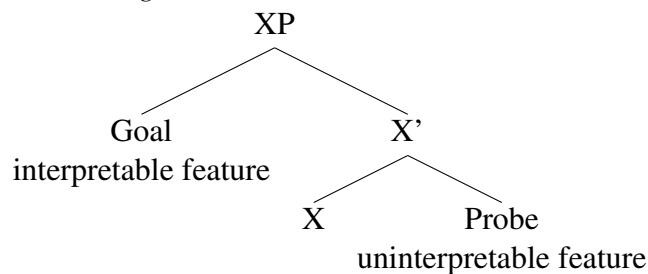

The arguments for treating agreement as Reverse Agree are the following. Firstly, Zeijlstra (2012) notes that there are various phenomena that appear to necessitate an upward agreement relation, such as negative concord. Zeijlstra proposes that negative concord is licensed under the operation of Agree, and given that negative words need to be c-commanded by the element carrying negation (either an unpronounced NEG operator or an overt NEG head, depending on the language type, see Zeijlstra 2004, 2012 for details), then AGREE must be able to look upwards (though see Bošković 2009a among others for a downward Agree approach). Zeijlstra gives further arguments from Sequence of Tense and Multiple Agree to support a Reverse Agree operation.

Similarly, Wurmbrand (2011, 2012a,b) utilizes (a valuation driven approach to) Reverse Agree in order to account for various other phenomena such as Parasitic morphology, verb clusters in Germanic, VP-ellipsis, control, anaphor binding, among others. To take one phenomena as an illustration, anaphor binding can be seen as involving an AGREE relationship: there is a deficient element (the anaphor) which requires some relationship with the higher element. Since anaphors often show agreement with their antecedent it is reasonable to suppose that they get these features through an AGREE relationship with the antecedent.¹⁴ If binding involves an AGREE relationship, then it must be a Reverse Agree relationship, since it is always the case that the antecedent c-commands the anaphor (see,

¹³Note that this is its interpreted position, it may be pronounced lower, but it is shown by Polinsky & Potsdam that its position of interpretation is high in the left periphery

¹⁴Within the binding literature, there is an opposing view, for instance Reuland (2001, 2011), argues that

among many many others Chomsky 1981, Lasnik 1989, Reinhart & Reuland 1993, Hicks 2009, Rooryck & Wyngaerd 2011, Reuland 2011 for thorough overviews).

In between these two opposing views are those that agreement can go either way in the structure (for instance Adger 2003, Baker 2008). Baker (2008) advocates for this approach, arguing that the necessity to recognize that agreement can go either way can be seen in the same language. Consider (220) from Icelandic (repeated from above). (220) has already been used to show that agreement must be able to look downwards, since T agrees with an object that is lower down in the tree. However, Baker (2008) also gives (221), where the adjective agrees with a subject (though recall that other analyses have been offered for this pattern). Baker argues that on the well-founded assumption (see den Dikken 2007 for comprehensive arguments in favor) that the subject of the predicate always c-commands the predicate adjective in (221), then the only conclusion to be drawn is that agreement must be able to in principle look upwards and downwards in the structure.¹⁵

(220) Um veturinn voru konunginum gefnar ambáttir
 In the.winter were.PL the.king.DAT given slaves.NOM
 In the winter, the king was given (female) slaves.

(221) Mara er góð
 Maria.NOM is good.F.SG.NOM
 Maria is good.

However, what is missing from these analyses, and addressed here, is that when the μ F value of an item differs from the i F value of that item on the same feature, and both can be agreed with, agreement with the i F requires a different configuration from the agreement with the μ F. The question becomes why i F agreement is restricted to operating only under a Reverse Agree configuration, but μ F agreement is not. The difference I will propose is that AGREE is a complex operation, which can be distributed across the domains of syntax and PF. Crucially, a Reverse Agree configuration must hold in syntax, but not at PF.

As mentioned above, regardless of whether one sees the operation of AGREE happening upwards or downwards it is generally taken to be the case that AGREE is a single operation: there is some feature that needs a value, which it gets from somewhere else. However, there is an increasing body of work (Benmamoun et al. 2009, Arregi & Nevins 2012, Bhatt & Walkow 2013) that suggests that the primitive operation of AGREE is split into two sub-operations, AGREE-LINK and AGREE-COPY, which do not necessarily have to take place in one go. The work cited above has taken it to be the case that AGREE

the relationship between binder and bindee is mediated through functional heads. Furthermore, Chomsky (1995) offers a view where binding is LF-movement of the anaphor.

¹⁵For Baker, this is a parametric option that languages differ on.

happens in the syntax alone. There are clear reasons for thinking that AGREE must be in part based in the syntax. However, it is also known that other effects come into play, which suggest that AGREE is in part post-syntactic. The clearest indication of this is the effect that linearity has on resolving agreement. Benmamoun et al. (2009) show that conjunct agreement is sensitive to linearity restrictions in both Tsez (222) and Hindi (223).¹⁶ In both languages, when the ConjP that controls agreement appears postverbally, agreement is with the left noun in the ConjP, whereas when ConjP is preverbal, agreement is with the rightmost noun:

- (222) a. kid-no uži-n Ø-ik'i-s [Tsez]
 girl.ABS.II-and boy.ABS.I-and I-went
 'A girl and a boy went.'
- b. y-ik'i-s kid-no uži-n
 II-went girl.ABS.II-and boy.ABS.I-and
 'A girl and a boy went.'
- (223) a. Ram-ne ek thailii aur ek baksaa (aaj) uṭhaa{-yaa /*-yii / ???-ye}
 Ram-ERG a bag.F and a box.M (today) lift{-PFV.M.SG /*-PFV.F / ???-PFV.M.PL}
 'Ram lifted a small bag and a box.'
- b. Mona-ne bazaar-me dekh-aa th-aa ek ghoṛaa aur kai
 Mona-ERG bazaar-in see.PERF-M.SG be.PST-M.SG a horse.M.SG and many
 kutte
 dogs.M.PL
 'Mona had seen a horse and many dogs in the market.'

Since linearity relations are assumed to hold only in the post-syntax than the syntactic derivation (see Chomsky 1995, Fox & Pesetsky 2005, but also Kayne 1994 for a proposal that linear order is syntactic), any agreement that is sensitive to linear relations should be (partly at least) based post-syntactically. Thus, it has been proposed that AGREE is split into two suboperations, AGREE-LINK and AGREE-COPY.¹⁷

3.3.2 Accounting for Semantic versus Morphological Agreement

I follow this decomposition of AGREE into two operations here. Arregi & Nevins (2012) give a two-step model as follows:

¹⁶Conjunct agreement is not always sensitive to linear restrictions, see for instance Bošković (2009b) on Serbo-Croatian.

¹⁷Bhatt & Walkow (2013) term AGREE-LINK *matching* and AGREE-COPY *valuation*. The terminology does not matter here, and I use AGREE-LINK and AGREE-COPY.

- (224) AGREE in Arregi & Nevins (2012)
 Agreement by Probe Γ with Goal γ proceeds in two steps:
- a. AGREE-LINK: in the syntax, Γ has unvalued ϕ -features that trigger Agree with γ (possibly more than one). The result is a link between Γ and γ .
 - b. AGREE-COPY: In the Exponence Conversion module, the values of the ϕ -features of γ are copied onto γ linked to it by Agree.

I follow this model with some important clarifications. Firstly, I assume that AGREE-LINK happens as soon as possible in the derivation, at the first derivational step when the controller and target of agreement are in the derivation. Furthermore, I do not assume that AGREE-COPY must happen post-syntactically. Rather, I assume that AGREE-COPY can happen within the syntax, at the point of transfer, in addition to being able to happen in the post-syntax. Secondly, I assume a crucial directionality distinction with respect to AGREE-COPY according to whether it happens syntactically or post-syntactically. If AGREE-COPY happens at the point of transfer, then it is only possible in a Reverse Agree configuration. That is, when AGREE-COPY happens at the point of transfer, it requires the controller to c-command the target. This directionality is relaxed at PF, where a relationship between controller and target is possible regardless of direction.

- (225) Agreement by Probe Γ with Goal γ proceeds in two steps:
- a. AGREE-LINK: a Γ has unvalued ϕ -features that trigger Agree with γ (possibly more than one). The result is a link between Γ and γ .¹⁸
 - b. AGREE-COPY: the values of the ϕ -features of γ are copied onto Γ linked to it by AGREE-LINK.
 - i. if AGREE-COPY happens at transfer, this requires that γ c-command the Γ .

It is worth elaborating on this model of Agreement somewhat. Firstly, it assumes that AGREE-LINK operations are established between a probe and a goal without this leading to immediate copying of the features from the goal onto the probe. As we will see below in chapter 4, I assume that AGREE-LINK happens as soon as both the probe and goal are in a configuration to do so, normally, the first point that both are in the derivation, with the rider that they are local enough, which I take fairly uncontroversially to be the same phase.

Furthermore, I assume in essence that there are multiple points, at least two, points at which AGREE-COPY can take place. The first point is at the point of transfer, the

¹⁸I do not assume that AGREE-LINK is only possible under Reverse Agree. The analysis can be restated this way, and is similar to an analysis of Agree which always happens under Reverse Agree (Wurmbrand 2011, 2012a,b, Zeijlstra 2012). See section 3.8 for discussion.

second point is after transfer somewhere along the PF-branch. Whilst it is not so controversial that agreement decomposes into two steps, AGREE-LINK and AGREE-COPY (it is assumed in some form in Benmamoun et al. 2009, Arregi & Nevins 2012, Bhatt & Walkow 2013, Marušič et al. 2015), that AGREE-COPY can happen at the point of transfer - that is, within the syntax, albeit right at the end - has not been discussed as far as I can see in the literature. The cited authors all take it to be the case that the valuation of features happens post-syntactically, with the search for the features guided by the AGREE-LINK relationship. However, it should be noted that such a view whereby AGREE-COPY happens exclusively post-syntactically is inconsistent with the phenomenon of semantic agreement, on the assumption taken here that the features relevant for semantics are not in the PF-component. Thus, it must be the case that AGREE-COPY happens within the syntax.

The mechanism of AGREE that I argue for is given below in (226), superimposed onto the Inverted T model of Bobaljik (1995, 2002). The numeration enters narrow syntax, and combines into the structure via Merge. Throughout the narrow syntax, AGREE-LINK creates a link between elements. Once all the operations of Merge and AGREE-LINK have taken place, the structure is transferred to the interfaces. At the point of transfer, I assume that this involves privileging where the *i*Fs are going to be interpreted by LF, and where the *u*Fs are going to undergo VI at during PF. Furthermore, the first operation of AGREE-COPY happens at the point of transfer. Since *i*Fs are still available, this is where any *i*F used in agreement must donate a value through AGREE-COPY. After transfer, the *i*Fs are sent to LF and play no further role in agreement. The *u*Fs remain visible to PF operations along the PF branch, and crucially any instances of AGREE-COPY happen throughout the PF branch. The key points to be taken away about the nature of AGREE is that AGREE-LINK happens throughout the syntactic derivation, whilst AGREE-COPY can happen during PF, where it can only see *u*Fs. However, there is a small window, at the point of transfer, whereby *i*Fs can take part in AGREE-COPY. Note that the only restriction on the precise moment when AGREE-COPY happens is that it must happen before the end of the derivation. Thus, it does not have to happen at the point of transfer.

(226)

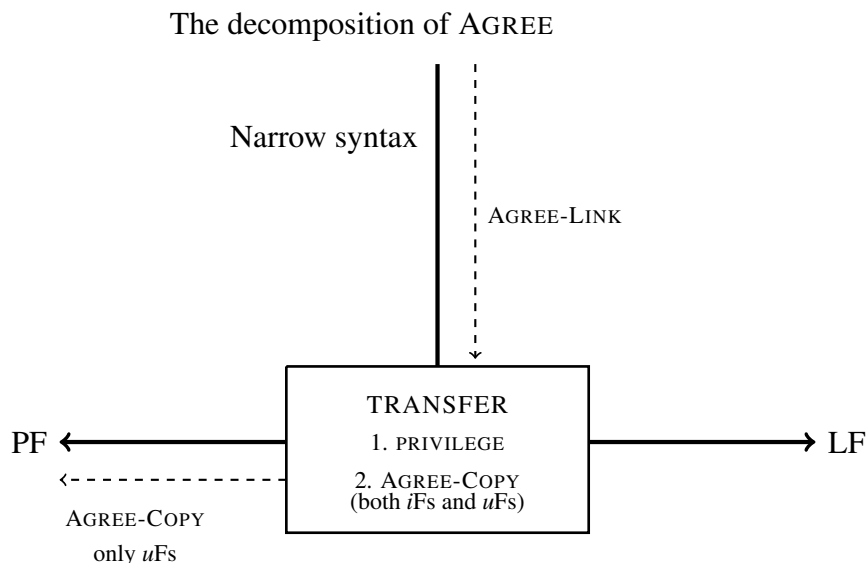

There are a couple of points worthy of fuller attention. As to why AGREE-COPY that targets *i*Fs happens only at the point of transfer, and why only in a Reverse Agree configuration, the simple answer is that that is where the data push us to. That it must happen in a Reverse Agree configuration is not so surprising in and of itself. Wurmbrand (2012a) shows that Reverse Agree underpins many relations that are clearly syntactic in nature involving *i*Fs, such as binding and control, where it is uniformly the case that the antecedent (=goal) must c-command the probe. As to why it happens *only* at the point of transfer is that if it were to happen freely during the derivation, then we might expect a derivation where AGREE-COPY happens, takes the values of the *i*Fs of the noun, which proceeds to reconstruct and leave the *i*Fs beneath the target of agreement. This would mean that semantic agreement is possible when the controller does not c-command the target at LF. Such derivations do not occur, nor do they with binding or with control. The simplest way that I can see to capture this is that there is only agreement at transfer, requiring a Reverse Agree configuration at LF.¹⁹

A further point of qualification is that the only restriction on AGREE-COPY that is made reference to in (225) is when it happens at the point of transfer it must do so in a

¹⁹ Note that a different way of looking at things would be to say that agreement happens in one step, but that depending on where it happens has a consequence on which features can be seen. We can then stick more closely to the existing proposals of Reverse Agree. However, this needs two things. Firstly, agree within the syntax has to happen at LF (Bobaljik & Wurmbrand 2005), for the reasons cited in text. Furthermore, agreement that happens post-syntactically can look either upwards or downwards in the structure. Both of these things are assumed more or less in the same way in the current approach, the difference being that instead of a one-step Agree operation I assume two. I discuss this further in the conclusions below.

Reverse Agree operation. This is important here, since it captures the fact that *i*Fs must c-command the goal at LF in order to control agreement. However, I make no qualification regarding what happens if AGREE-COPY happens post-syntactically. This releases *u*Fs from needing a Reverse Agree configuration, and hence they can control agreement even when they are in a position that doesn't c-command the goal. I take no stand on whether post-syntactic AGREE-COPY requires c-command or not, opening up the possibility, but not necessity, of agreement operating according to linear relations.²⁰

Now we must add one final component. I assume that for genuine operations of AGREE, *u*F agreement is the general case across languages, and that *i*F agreement is the special case. Generally then, AGREE-LINK will create a link between the *u*Fs on the controller and the target. In order for *i*F agreement to be possible, I assume that the *i*Fs of the controller must be *active*, and only then can the *i*Fs of the controller be linked to the target via AGREE-LINK. If the *i*Fs are active on a controller, they take precedence over *u*F agreement.

(227) If the *i*Fs are active on a controller, then AGREE-LINK links them to the target, as opposed to the *u*Fs.

Once we put all of these things together, we end up with the effect that *i*Fs can only be targeted for agreement when they c-command the target at LF, and when they are active. Consider how all of this works for scope reconstruction, which has been argued to involve differences in copy interpretation (Fox 2000), whereby the copy that is semantically interpreted is different from the copy which is phonetically realized. In the current terms, we can see this as the *i*Fs being privileged in a different position to the *u*Fs.

Consider the scopally ambiguous sentence (228), with the derivation in (229), I assume that the DP *a boy* merges in first in the lower clause, and then remerges in the higher clause. As the structure is being built, AGREE-LINK happens, and T probes the DP, creating a link between the two that is the input to AGREE-COPY later on.²¹

(228) A boy is likely to win the game. ∃ ≫ likely / likely ≫ ∃

²⁰Note that simply assuming that AGREE-COPY can happen post-syntactically does not entail that all agreement that takes place after syntax makes use of linear order. If the linearization algorithm happens also within the post-syntactic component, but after the point of AGREE-COPY, then it will remain subject to hierarchical relations. Arregi & Nevins (2012) take this view. However, it should also be borne in mind that AGREE-COPY can also in principle happen after linearization, and then we should expect linear relations to matter. I leave this matter here, but the reader should bear in mind that a post-syntactic AGREE-COPY operation does not inevitably lead to linearity-based agreement. For more discussion on this matter, see section 3.7 below.

²¹Irrelevant structure omitted in (229).

(229)

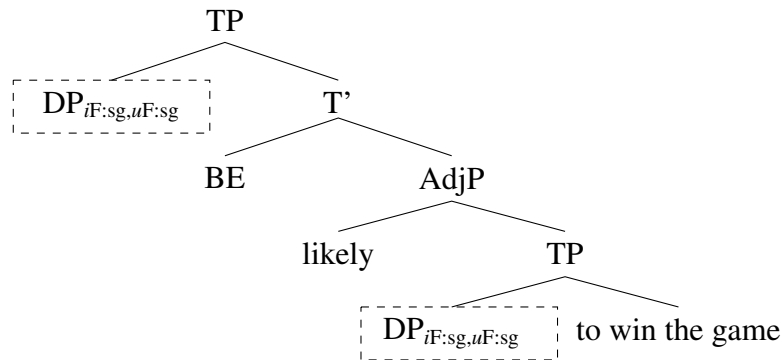

At the point of transfer, PRIVILEGE determines where the *i*Fs and the *u*Fs are to be realized in the tree. In the case of no reconstruction, both are realized as high in the tree, and pronounced and interpreted in the same position. If AGREE-COPY happens at transfer, then both the *i*Fs and the *u*Fs of the DP can determine the value of T. If the *i*Fs are active, then AGREE-LINK will have chosen them, and AGREE-COPY must copy the values of the *i*Fs to the target. If the *i*Fs were inactive, then AGREE-LINK chooses the *u*Fs. On the other hand, if AGREE-COPY happens post-syntactically in PF, then only the *u*Fs will be able to value the features on T, as they are the only features left in the derivation. Because *a boy* is a noun where the *i*F:# and *u*F:# do not mismatch, we obtain the same output whatever happens here in this example.

(230)

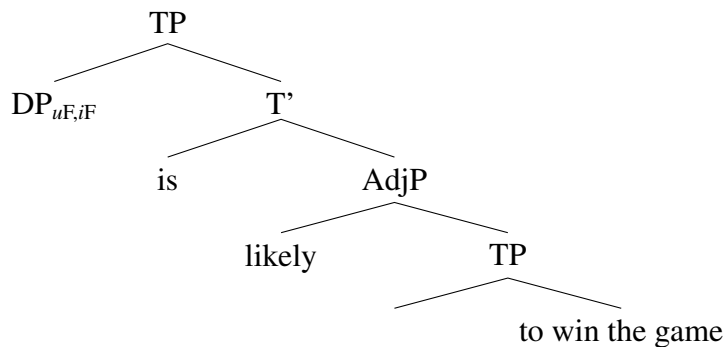

More interesting are cases where PRIVILEGE chooses different positions for the *i*Fs and the *u*Fs of a DP, as shown below in (231).

(231)

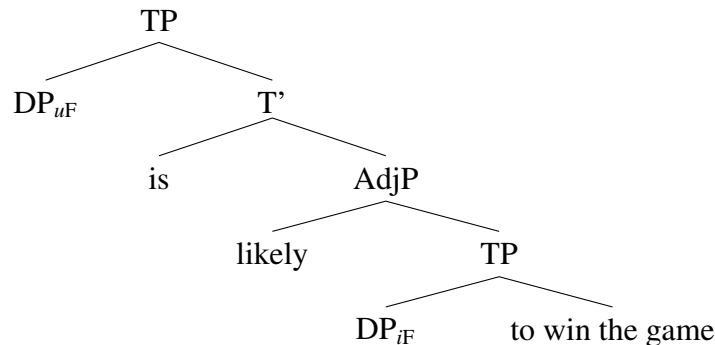

At the point of transfer, PRIVILEGE happens, and chooses the high position for the u Fs of DP (so *a boy* is pronounced before *likely*), but the i Fs are located in the low position (so *a boy* is interpreted within the scope of *likely*). As will be discussed in greater detail in the following section, the i Fs will not be able to enter into agreement in this configuration. We wind up deriving the effect that for i F agreement to be possible, the i Fs must c-command the target of agreement at LF.

3.4 Back to semantic agreement with CNPs

3.4.1 Why LF-visibility holds

Since the u Fs and i Fs of a garden-variety noun like *a boy* are the same, we cannot reliably identify when the i Fs control agreement, as it would be indistinguishable from morphological agreement. However, if we return to CNPs, this model captures the fact that when there is plural agreement, the CNP will not be able to reconstruct for scope. Recall the relevant pattern:

- (232) a. A northern team is likely to be in the final. $\exists \gg$ likely / likely $\gg \exists$
 b. A northern team are likely to be in the final. $\exists \gg$ likely / *likely $\gg \exists$

For semantic agreement to be possible in this instance, and yield the plural value of the auxiliary, our assumptions require that the (plural) i F on *a northern team* be both active and in Spec,TP. If the semantics interprets them in the lower clause, then they are unable to control agreement on T^0 . Thus, in (233), semantic agreement is possible on T^0 , since the i Fs of *a northern team* lie in the correct Reverse Agree configuration. Throughout the derivation, if the i Fs are active on the CNP, then AGREE-LINK links T to the i Fs on the CNP. As the values on the i Fs can only be copied at the point of transfer – remember

only the u Fs are present along the PF-branch – then AGREE-COPY must happen at the point of transfer. Since the CNP is interpreted with wide scope, it is in Spec,TP of the higher clause, and the necessary Reverse Agree configuration holds; the values of the i Fs are successfully copied to T.

(233)

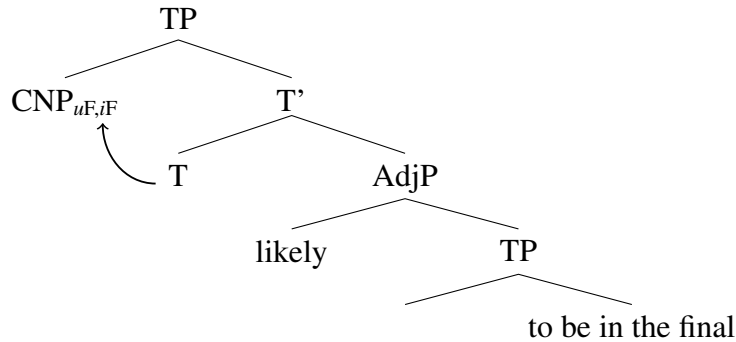

In (234) however, the i Fs are inaccessible for agreement. Therefore, the only possible agreement is with the u Fs of the CNP. Suppose that the i Fs enter the derivation as active. As i Fs are agreed with wherever possible, AGREE-LINK will link T to the i Fs of the CNP. If PRIVILEGE then applies, and the low position is chosen for the i Fs, then the necessary Reverse Agree configuration does not hold, and i F agreement fails. Thus, the derivation can only work if the i Fs are not active. Then, the u Fs of the CNP will be chosen for T by AGREE-LINK, and the values can be successfully copied via AGREE-COPY. It does not make a difference whether this happens at transfer or post-syntactically.

(234)

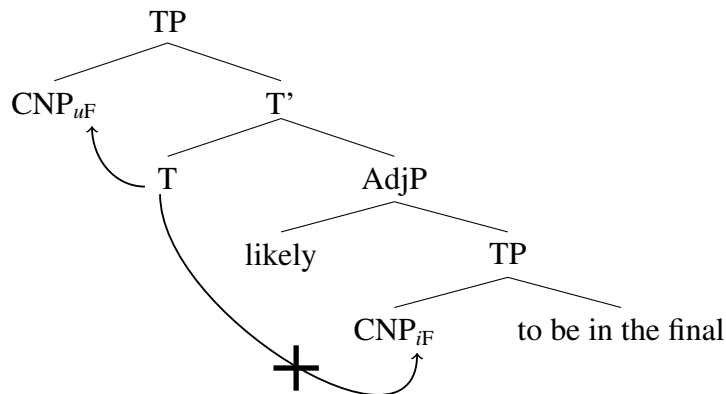

In addition to capturing the facts of why semantic agreement is not possible if the CNP reconstructs, we also gain an explanation for the predicate/subject alternations given

by den Dikken (2001). The same principle is at play here. In section 3.2.2 I motivated the proposal that in the subject reading of the sentences, the CNP lies in Spec,TP at LF, whereas in the predicate readings, it lies beneath the CNP. The difference between them is that in the predicate reading, the CNP is the predicate in an inverted structure, whilst in the subject reading, the CNP is simply the subject of the predicate construction. Coupling this with the proposal of Heycock (1995), that predicates obligatorily reconstruct at LF, we end up with the controller of agreement (the predicate) being beneath T^0 in the predicate reading, but in the subject reading the controller (the subject) is above T^0 . Thus, semantic agreement is possible in the subject reading but not the predicate reading.

- (235) a. The best committee is theirs. committee = ✓ subject / ✓ predicate.
 b. The best committee are theirs. committee = ✓ subject / ✗ predicate

- (236) a. The best committee belongs to them. (subject reading)
 b. The committee that they belong to is the best committee. (predicate reading)

- (237) Subject Reading: *the best committee* = subject

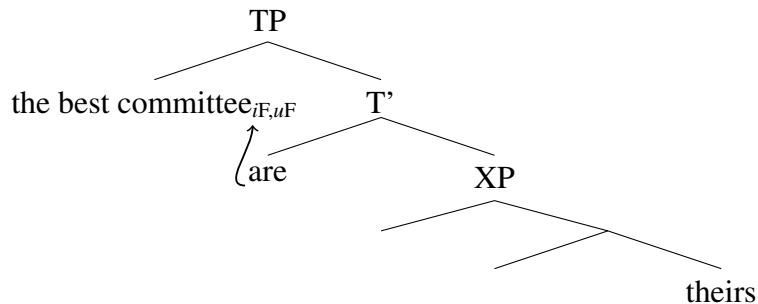

- (238) Predicate Reading: *the best committee* = predicate

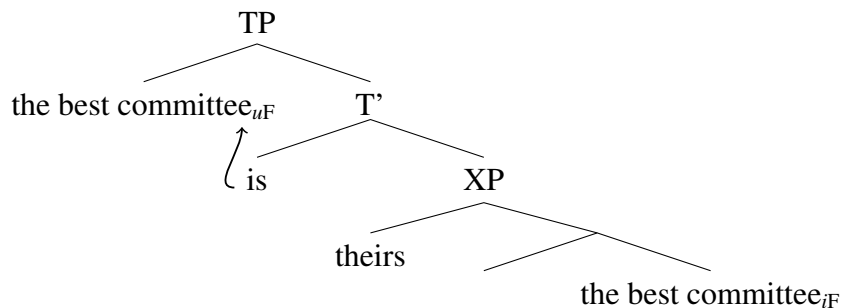

Finally, we can understand why semantic agreement is not possible in existential constructions.

- (239) a. There is a committee deciding the budget for next year.
 b. *There are a committee deciding the budget for next year.

Recall from the discussion above that the associate DP in existential constructions never raises into Spec,TP in existential constructions (see in particular (196) above for motivation). Thus, in existential constructions, there never is the required configuration in the derivation for the *i*Fs on the CNP to be accessed for agreement. Even if the *i*Fs on the CNP entered the derivation as active, and AGREE-LINK links them to T, their values would not be able to be copied. Rather, for the derivation to converge, the *i*Fs must be inactive, allowing AGREE-LINK to link the *μ*Fs on the CNP to T, and AGREE-COPY happens along the PF-branch, where it can look down in the structure.

(240)

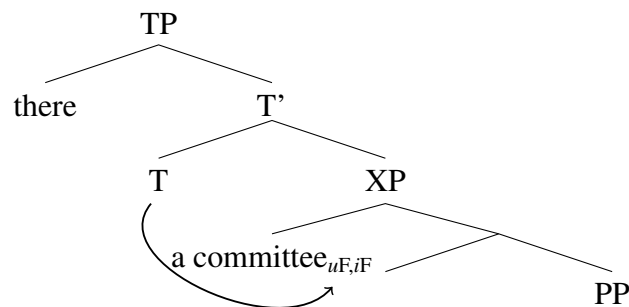

3.4.2 Part 3: Comparison with other theories

Above I have presented an account whereby semantic agreement in British English is restricted in certain cases because the *i*Fs on the CNPs are unable to be accessed for agreement. The fact that *i*Fs are in certain situations unable to be accessed accounts for the distribution seen in British English according to where semantic agreement is allowed or disallowed. There have been other approaches in the literature to try to explain the facts of British English, and here I offer a comparison between the present analysis and other attempts.

We can group these other analyses into two main strands of thinking. One of these strands posits that CNPs that control plural agreement are qualitatively different from their counterparts that control singular agreement. That is, CNPs that control plural agreement have something added to them, which allows them to (obligatorily) control plural agreement, however that added aspect to the CNP renders them unable to appear in certain syntactic contexts. The other strand of research is more similar to the approach posed here, whereby it is the plural feature that is somehow different from the others.

3.4.2.1 Plural agreeing CNPs are different

Den Dikken (2001) and Sauerland (2004a,b) have argued for similar approaches, claiming that plural agreeing CNPs are different from their singular agreeing counterparts since they involve some extra element, which turns the regular singular CNP into a plural one. For den Dikken, this element is plurally specified *pro* which combines in apposition with the CNP.²² For Sauerland, the plurality is obtained by the addition of a plural operator Γ^{-1} .

Den Dikken claims that *pro* causes the change to plurality in CNPs because it heads the resulting DP, and so the plurality of *pro* is obtained by the CNP as a whole. The pronominal nature of *pro* in turn causes the entire DP to take on the nature of being pronominal, and this causes the restrictions on plural agreement. Den Dikken proposes that the fact that you cannot get plural agreement in existential constructions derives from the fact that pronominals are not allowed in general to be the associate of existential sentences, a fact that is presumably related to the definiteness requirement on existential sentences in English and various other languages. Furthermore, den Dikken claims that the fact that the sentence in (191b) lacks the predicate reading that is given in (192b) falls out from the fact that plural pronouns are barred from predicate positions in general. If it is true that plural pronouns are prohibited from being in predicate position, then plural agreeing CNPs are barred from that position too, since *pro* forces them to become plural pronouns. Singular agreeing CNPs, lacking *pro*, are however allowed to be predicates, since singular pronouns such as *it* are grammatical according to den Dikken, for instance *you are it*, and *Coke is it*.

It is not clear that den Dikken's generalization about plural pronouns not being able to be predicates is correct however, since there do exist contexts in which they seem to be acceptable, though they are not widespread (see also Bošković 2002, footnote 35):²³

- (241) a. We have met the enemy and he is us.
b. There are gods and we are them.

Regardless of the status of plural pronouns being in predicate position, a far more serious problem for den Dikken's approach is that a single CNP can trigger both singular and plural agreement in the same sentence:

- (242) a. This committee are deciding the future of the project.
b. The government has offered ?themselves / each other up for criticism.

²²A conceptual problem, in addition to the empirical ones discussed below for den Dikken is that this *pro* would constitute the only instance of *pro* in English, since English does not have null pronominals more generally.

²³Thanks to Jonathan Bobaljik p.c. for pointing these out to me.

For the approach that den Dikken takes, namely positing some element that makes a singular CNP a plural one, this is unexpected. Once *pro* has combined with the CNP then only plural agreement should be possible. However, the presence of singular agreement on the demonstrative indicates that the CNP is singular. The presence of two types of agreement seems like a paradox for this approach. Den Dikken does acknowledge sentences like (242a), and proposes that plural agreement is not possible with demonstratives because *pro* prevents the demonstrative from combining with the CNP. However, this fails to account for the grammaticality of (242b). Both anaphors and auxiliaries can independently show plural agreement, so it is not possible to claim that the singular agreement on the auxiliary results from a general inability of the CNP to trigger plural agreement on some element. For den Dikken's approach, (242b) is a real problem, as are the following, which illustrate the same issue:

- (243) a. The faculty has decided to recuse themselves since there is a clear conflict of interest.
 b. The committee has decided to give themselves increased powers.

On the approach taken here, there is no problem of there being mismatches between the agreements. All that needs to be said is that the anaphor agrees with the *iF:plural* feature of the CNP, whilst the verb agrees with the *uF:singular* of the CNP.

Sauerland (2004a,b) takes a similar approach to den Dikken, but instead of positing a plural *pro* combining with the CNP to turn it plural, he instead proposes that the culprit is a plurality operator. This in turn, he argues, makes the CNP a definite noun phrase, since the plurality operator Γ^{-1} is of the semantic type $\langle e, e \rangle$. Sauerland claims that this is the case even when CNPs combine with the indefinite article *a*; they may look like they are indefinite DPs but are in fact hidden definites, as Sauerland terms them. It is this that prevents plural agreeing CNPs from appearing in the environments in which plural agreement is disallowed. As mentioned above, there is a well known definiteness restriction on existential sentences. Due to the fact that it is the plural operator on CNPs that allows them to control plural agreement, plural agreement triggered by CNPs is disallowed in existential sentences, since the plurality causes them to become definite, making them disallowed in existential constructions. Secondly, as shown above, CNPs are not allowed to reconstruct for scope when there is plural agreement but they are when there is singular agreement.

Sauerland claims that the definite nature of plural CNPs captures this fact, since definite expressions in general do not reconstruct. Indefinite expressions are able to do so, so there is no problem with singular CNPs reconstructing into the embedded clause. Sauerland's approach however offers no explanation as to why plural agreeing CNPs are barred from acting as predicates, since there is no general definiteness restriction on predicates:

- (244) a. John is *the man you need to talk to*.

b. Mount Everest is *the highest peak on earth*.

Sauerland's approach, in addition to providing only a partial explanation of the facts further suffers from the same problems that den Dikken's does with respect to there being both singular and plural agreement triggered by the same CNP. In fairness to Sauerland, his account is able to capture why demonstratives do not take plural agreement, since he can draw a distinction between DP-internal and DP-external agreement. Since the operator that turns CNPs into plural is located above the position of demonstratives, and agreement looks downwards, then the demonstrative can see a singular value on the noun, but DP-external agreement will see plural agreement:

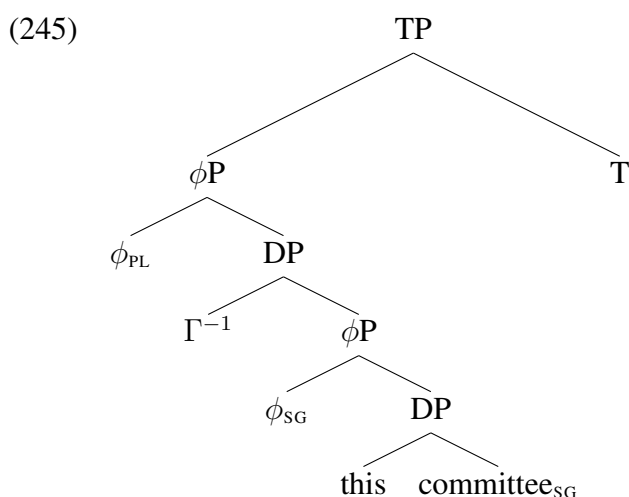

However, there is no way that two DP-external agreements should mismatch, as is the case in (242b) and (243). A further problem for the style of approach that den Dikken and Sauerland take is that once we look more closely at existential constructions, we find that CNPs are able to control plural agreement from the associate position of existential sentences. They are unable to trigger plural agreement on the auxiliary, but other elements are free to show plural agreement. This can be seen in the following, where the CNP licenses a plural anaphor in the lower clause:

(246) There is a team starting to psych themselves up in that dressing room.

Given the existence of sentences like (246) (noted by Elbourne 1999), an analysis where plural agreeing CNPs are unable to appear in the associate position of existential sentences seems extremely hard to maintain. Den Dikken speculates that the reason that these sentences are grammatical is that they all contain adjuncts with a PRO subject and that the “featural connection between PRO and its controller can be relatively loose” (den

Dikken 2001:34). However, he further notes that an analysis of partial control (Landau 2000) is unlikely due to the fact that plural anaphors are licensed. Without some kind of mechanism that captures this aspect of CNPs, we must remain skeptical that treating plural agreeing CNPs and singular agreeing CNPs as two different creatures is the correct approach. Once we couple this with the fact that a single CNP can license both singular and plural agreement, then we are pushed to question the assumption that the choice of agreement really reflects separate CNPs, and move towards a theory whereby CNPs are simultaneously singular and plural.

3.4.2.2 All CNPs are the same

Elbourne (1999) claims that all CNPs in British English have regular singular number, but they are also specified with a *mereology* feature, a special type of number feature that expresses collective plurality. In essence then, CNPs are simultaneously singular and plural, since they contain both singular and plural number features. This immediately allows us to account for the fact that both singular and plural agreement can be triggered by the same CNP, for instance in (242a). Furthermore, there is no longer any problem with a CNP being able to antecede plural anaphors in existential constructions because CNPs are allowed to appear in existential constructions; it just appears to be the case that plural agreement is not possible on T^0 .

In order to account for the contexts where plural agreement is not licensed, Elbourne resorts to a difference in the behavior of the two number features: a regular number feature is able to raise to a position covertly, but *mereology* is not. That is, the only way to move *mereology* is to move it in the narrow syntax, before transfer to the interfaces. This works for Elbourne in the following way. In existential sentences, Elbourne adopts the analysis of Chomsky (1995), where the associate in existential sentences remains low in the structure, before the features raise to Spec,TP covertly to check the agreement features on T. For Elbourne, this rules out plural agreement in existential sentences because the plural feature is unable to join the other features in raising covertly. Singular agreement is fine because the regular number feature, singular on CNPs, faces no problems in raising covertly.

For the scope reconstruction cases, Elbourne appeals to the approach of PF-movement in Sauerland (1998) whereby scope reconstruction effects are actually movement of an element on the PF branch without a corresponding movement in the narrow syntax or on the LF branch of the grammar. This gives the effect of raising an element in the surface form of the sentence, but leaving it in the original place for the purposes of the semantics. The phi-features of the element must still be checked however, and this is done by covert feature movement. Consider the wide scope and narrow scope readings of the following sentence:

(247) A person is likely to win the lottery. person \gg likely/ likely \gg person

In the narrow scope reading, where it is likely that some person will win the lottery, a person remains in the embedded clause, but in the PF branch, it moves into the matrix clause to occupy its surface position. This produces the mismatch where it is pronounced in the higher clause but interpreted in the lower clause. In the low position, its uninterpretable phi-features must still be checked by spec-head agreement with T, following Chomsky (1995), and so they raise covertly to Spec,TP. In the wide scope reading however, *a person* moves regularly in the narrow syntax into the higher clause. This takes with it all its features, and so it is interpreted in the high position.

Returning to CNPs, we see that the reason why plural agreement is disallowed is the assumption that *mereology* cannot raise covertly. Plural agreement is not possible when there is a narrow scope reading of the CNP, since this requires movement of the CNP in the PF branch, followed by covert movement of the features to Spec,TP. With *mereology* unable to raise covertly, the plural feature on T⁰ is unable to be checked and so the derivation fails. The wide scope reading is fine since the CNP moves in narrow syntax taking all its features, including *mereology*, with it to the matrix clause. By contrast, singular agreement is fine when the CNP remains low in the syntax but moves into the high position in the PF branch; covert feature movement is not a problem for the singular number feature, and the derivation is able to successfully converge.

Whilst Elbourne's approach does capture the facts from existential constructions and scope reconstruction, it does suffer a number of shortcomings. Firstly, it only offers a partial explanation of the facts; it is not clear how the asymmetry between subject readings and predicate readings can be resolved in this system. Further problematic is that covert feature movement, or the lack of it with respect to *mereology*, in fact seems to be largely irrelevant in existential constructions. den Dikken (1995) gives the following paradigm, showing that if features did move covertly to Spec,TP, then we would expect the anaphors in the following sentences to be licensed, contrary to fact:

- (248) a. Some applicants_{*i*} seem to each other_{*i*} to be eligible for the job.
 b. *There seem to each other_{*i*} to be some applicants_{*i*} eligible for the job.²⁴
 c. Someone_{*i*} seems to his_{*i*} mother to be eligible for the job.
 d. *There seems to his_{*i*} mother to be someone_{*i*} eligible for the job.

²⁴(248b) is explainable by the covert raising analysis that Elbourne assumes, since the anaphor *each other* would raise in LF to check the features of the verb, if one assumes the LF-movement approach to binding of Chomsky (1995), though this leaves (248d) unexplained. Thanks to Ž Bošković (p.c.) for pointing this out to me.

These facts suggest that the associates in existential constructions remain low in the structure at all levels of representation, and never in fact raise to Spec,TP. Taking this to be true, then covert feature movement is irrelevant in existential sentences, and Elbourne loses the explanation of these sentences and is left covering only the cases where scope reconstruction is disallowed with plural agreement.

3.4.2.3 Summary of comparison

As shown, the problem of plural agreement with CNPs has been approached in different ways by different people, but the result is an incomplete analysis of all the contexts where plural agreement is disallowed. On the other hand, the approach offered here accounts for all the environments where plural agreement is allowed and disallowed, whilst also capturing the fact that CNPs can be simultaneously singular and plural.

(249)

	Smith	Den Dikken	Sauerland	Elbourne
Scope reconstruction	✓	✓	✓	✓
<i>there</i> -constructions ²⁵	✓	✗	✗	✗
Predicate position	✓	✓	✗	✗
Hybrid nature	✓	✗	✗	✓

3.5 Aside: On the movement of features within DP

In the above discussion, I have tacitly been assuming that for DP-external agreement, the agreement takes place between the target and the DP layer of the CNP. This is a standard assumption in the literature, that the features within DP make their way up to the top. However, for the approach taken in this thesis, such a process is not so easy.²⁶

The problem is the following. In an approach whereby features are introduced on dedicated functional projections, there must be some method of transmission in order to get the features up to the DP layer. In the AGREE framework Chomsky (2000, 2001), coupled with Bare Phrase Structure Chomsky (1995), this can be done by assuming that D⁰ undergoes an AGREE relation with the functional heads, which transfers the features

²⁵Whilst Elbourne, den Dikken and Sauerland each offer an account of existential constructions, as pointed out above, each analysis faces serious issues. For den Dikken and Sauerland the problem arises from the fact that a plural anaphor can be licensed in existential sentences, whereas for Elbourne, the issue is that there is no evidence that the associate DP raises into Spec,TP.

²⁶My thanks to every syntactician on my committee for pointing out this issue to me.

up to D^0 . Since D^0 is the head, its features, and those it acquires, will be visible to external relationships.

However, under the assumptions pursued here, such an Agree relationship cannot transfer the *i*Fs of functional heads without them c-commanding D^0 at LF. *i*Fs can only be copied by AGREE-COPY when it happens at the point of transfer, which further requires the controller to c-command the target. Thus, in order for *i*Fs to get to D^0 , via AGREE, there must be wholesale movement of functional heads to a position above D^0 ,²⁷ coupled with reconstruction of the *u*Fs so they are pronounced beneath D^0 .

Thus, AGREE does not work for our purposes here. A different option is that there is some mechanism of feature percolation that forces features to percolate from these functional heads up to D^0 . In this way, the *i*Fs could percolate from their base position, upwards until they reach D^0 . Yet percolation mechanisms introduce a redundancy into any framework which also assumes AGREE, since then there are two mechanisms which move features around without the structure.

A third option is that feature transmission, within DP at least, comes from the operation of Merge itself, such that when two objects are merged, the result is that the mother node obtains the unification of the features on the daughter nodes (see Van Koppen 2012, who proposes this mechanism following Dalrymple & Kaplan 1997 and van Koppen & Rooryck 2008). I adopt this mechanism here, noting the shortcoming identified by (Van Koppen 2012, fn. 13) that this percolation must stop in the derivation.

To illustrate, consider the following somewhat truncated example. Suppose that a $\sqrt{\text{ROOT}}$ combines with *n* carrying some feature *F*, which then combines with NumP before the whole thing combines with D. At each stage of merge, the resulting mother node obtains the unification of features on the sister nodes:

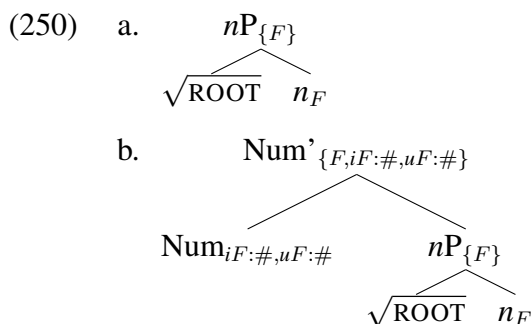

²⁷Presumably to Spec,DP, since if it were a higher projection, then D would need to project even higher in order to be at the top of the structure and render the features visible at the top of the DP. However, if D^0 merges higher, then the features on the moved functional heads would be not accessible, so they would need to merge higher, which would force D^0 to merge higher and so on *ad infinitum*.

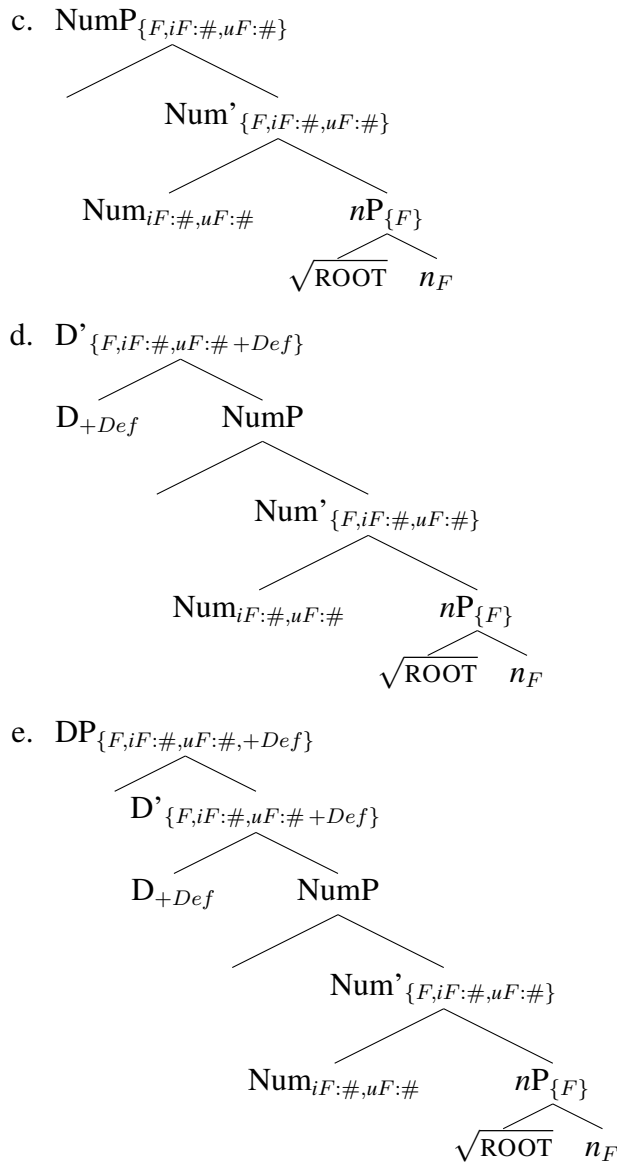

This mechanism will also play a role in chapter 4, since it allows for DP-internal elements to undergo *iF* agreement, since when they undergo adjunction, they will be able to see the features on the segment that they attach to.²⁸ Take a language where plural

²⁸Recall that just because *iF*s will be on DP, it does not mean that they are always available for DP-external agreement. Whilst a Reverse Agree configuration is necessary, it is not sufficient: the *iF*s must also be active for agreement. Thus, even though the inherent *iF* on a fake mass noun like *furniture* (see chapter 2) will be in a position where it can agree, the *iF*s of fake mass nouns are not active, and this semantic

morphology is realized synthetically, and that this indicates that the root has moved up to Num creating a complex head. Now, if adjectives adjoin to NumP, creating a complex category at the site of adjunction, then they will c-command a segment of NumP that has the number features on it. In the following, the adjective labeled X c-commands the segment of NumP labeled Y.

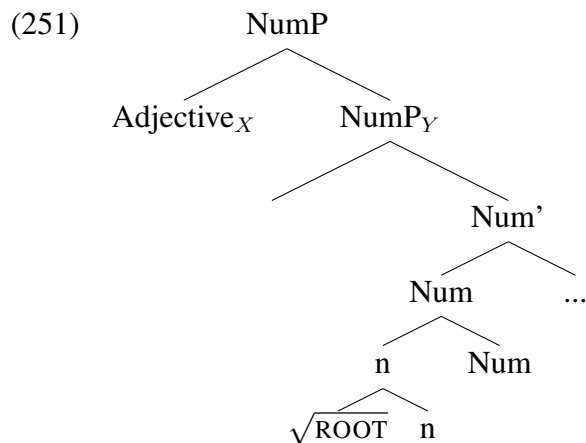

3.6 Semantic agreement in Russian

After a couple of digressions, we move to Russian to look at another area where semantic agreement is allowed as a general phenomenon. Specifically, I will look at how agreement is resolved with QNPs in Russian. These data are interesting because they show broad support for two of the ideas presented above, namely that *i*F agreement is a more restricted process than *u*F agreement, and that *i*F agreement is only possible in an upward configuration.

3.6.1 Agreement in Russian: Looking everywhere

Russian agreement broadly follows the same rules that are familiar from many Indo-European languages: agreement is controlled by the NP that has nominative case.²⁹

- (252) Maša priglasila nas v gosti
 Masha.FEM.SG invited.FEM.SG us in guests
 ‘Masha invited us to her place.’

agreement is not possible with these nouns. For more discussion on this point, see chapter 4.

²⁹Unless otherwise noted, examples are taken from Glushan (2013).

Agreement is obligatory, and barring the QNP data in the next section, targets that are potential controllers of agreement cannot be ignored. Therefore, in the following, the agreement value on the verb *must* be plural if the controller is plural, rather than revert to a default singular value:

- (253) a. studenty byli v komnate
students was.PL in room
'Students were in the room.'
- b. student byl v komnate
student was.SG in room
'A student was in the room.'
- c. stulja byli v komnate
chairs was.PL in room
'Chairs were in the room.'
- d. stul byl v komnate
chair was.SG in room
'A chair was in the room.'

Agreement with an NP that is in nominative case is generally taken to reflect the *uF* features of the NP, which as is regularly the case, lines up with the values of the *iFs* of the NP. However, the divergence between the two, and the fact that agreement tracks the set of *uFs* on the noun comes from compound numeral cases where the final numeral is 'one', for instance *twenty one*. In the following, despite the fact that a set of twenty one leaves is clearly a plurality, we can see singular agreement. Thus, the numeral 'one' in the structure renders the feature set on the noun to be [*uF*:singular]. Agreement therefore tracks the *uF* value, as opposed to the *iF* value.

- (254) S dereva napadal/*napadalo dvadcat' odin listik
from tree na-fallen.M.SG/*na-fallen.N.SG twenty one leaf.M.SG
'Twenty one leaves have fallen from the tree.'

This is important, because it establishes the fact that agreement in Russian generally tracks the *uFs* of the noun, even though these in large part may line up with the *iFs*. Crucially, when they do not line up, it is the *uFs* that are reflected by agreement, not the *iFs*.

Agreement with nominative arguments in Russian is possible across a wide domain. Elements that must remain low in the structure are able to control agreement on the verb. For instance, in the following locative inversion structure, the subject remains low in the derivation (Glushan 2013), but is the controller of agreement.

- (255) Na ulice stojali/*stojalo dorigie mašiny
 on street stood..PL/*stood.N.SG expensive cars
 ‘There were expensive cars parked in the street.’

3.6.2 QNPs in Russian

The data that interest us come from quantified noun phrases (QNPs). These nouns are curious for us, because in contrast to the examples given above, it has been noted that they do not show obligatory agreement, but rather optional agreement with the verb. Consider the following cases:

- (256) Pjat’ krasivyh devušek prišli/prišlo
 five beautiful girls arrived.PL/arrived.NEUT.SG
 ‘Five beautiful girls arrived.’

In the above, *pjat’ krasivyh* ‘five girls’, seems to be able to control either plural or neuter singular agreement on the verb. These nouns are particularly interesting for our purposes, because they have been analyzed in various places as being caseless (Glushan 2013). To the extent that this is true, they fall outside the usual rules for agreement in Russian, which rigidly tracks nominative case.³⁰ Glushan argues that when QNPs do agree, this is an instance of semantic agreement, specifically, the failure of nominative agreement opens up the possibility of agreement with the *i*Fs of the controller.³¹

Since the QNP in (256) denotes a plurality, plural agreement on the verb reflects the semantic value of the NP.³² If plural agreement reflects *i*F agreement, then where does the neuter singular agreement come from? The answer that is traditionally assumed is that it reflects a default agreement on the verb, in that the QNP has failed to control agreement and so a default value must be used.

The reason for this failure of agreement has been argued to be related to case; various people have assumed that QNPs are ambiguous between having case and not having case (see Pesetsky 1982, Franks 1994, Bošković 2006b, Glushan 2013). In case they have

³⁰Though it should be noted that there are proposals that treat QNPs as being only optionally marked for case, (Pesetsky 1982, Franks 1995, Bošković 2006b).

³¹The lack of *u*F agreement will not inevitably lead to *i*F agreement. Željko Bošković (p.c.) points out that in the same scenario in Serbo-Croatian, semantic agreement is not found, but rather default agreement. I assume that in this case, the *i*Fs of QNPs in Serbo-Croatian are not active for agreement, see chapter 4 below.

³²For clarity in what follows, I adopt the proposal of Bošković (2005) *et seq.* advocating that languages like Russian, where there is no definite article, do not have the functional projection DP in the language at all. NPs are therefore bare in these languages. The DP/NP debate plays no role here, but is adopted for clarity of terminology.

case, they control agreement on the verb, but if not, T-agreement fails and we see default morphology on the verb.

That these QNPs allow the *u*Fs that usually play the controlling role in Russian to be bypassed in favor of *i*F agreement allows us to test *LF-visibility* against a wider set of data. Based on what was proposed in section 3.2, we make predictions of where *i*F agreement should be possible with Russian QNPs: *i*F agreement should be possible only if the QNP c-commands the target of agreement (T^0 here) at LF.

There is a lot of support that this is in fact the case. Consider the facts below. When plural agreement is on the verb, the QNP is allowed to bind a reflexive in object position, however, when there is only singular agreement, binding is not possible (Franks 1995).

- (257) a. Pjat' ženščin smotreli/smotrelo na Ivana
 five women looked.PL/looked.N.SG at Ivan
 'Five women looked at Ivan.'
- b. Pjat' ženščin smotreli/*smotrelo na sebja
 five women looked.PL/looked.N.SG at themselves
 'Five women looked at themselves.'

Franks (1995) argues that this shows the QNPs to be in Spec,TP when they control plural agreement, which in turn allows them to be the antecedent for the anaphor. He assumes that antecedents must lie in Spec,TP in order to bind the reflexive.³³ He also proposes that this is the case for when the QNP controls a PRO in an embedded gerund: the antecedent must be in Spec,TP for this to be licensed. We expect then that plural agreement should be obligatory when the QNP needs to control a PRO in a gerund, which is true:

- (258) a. Po doroge domoj, pjat' malčikov zašli/zašlo v magazin
 on way home five boys dropped.in.PL/dropped.in.N.SG to store
 'On their way home, five boys dropped into a store.'
- b. Vozvraščas' domoj, pjat' mal'čikov zašli/*zašlo v magazin
 returning home five boys dropped.in.PL/dropped.in.N.SG to store
 'Returning home, five boys dropped into a store.'

More evidence that Spec,TP is crucial for licensing semantic agreement comes from how agreement is resolved when the controller is an inanimate QNP subject in an intransitive clause. Glushan shows that there is an important animacy distinction with QNPs (this has been noted in surveys by Corbett 1983, Robblee 1993). Animate QNPs optionally control *i*F agreement on the verb, whereas inanimate QNPs are apparently unable to

³³The reflexive is subject oriented here, and is assumed to lie at least in Spec,vP (see Franks 1995).

control *iF* agreement on the verb. For now I ignore the fact that *iF* agreement is optional from animate QNPs. This will be discussed in greater detail in sections 3.6.3 and 3.6.4.

- (259) a. Pjat' studentov prišli/prišlo
 five students.GEN arrived.PL/arrived.N.SG
 'five students arrived.'
 b. Pjat' pisem ??prišli/prišlo
 five letters.GEN ??arrived.PL/arrived.N.SG
 'five letters arrived.'

Simplifying somewhat for ease of exposition, Glushan argues that the reason why inanimate QNPs, in this instance, are unable to control *iF* agreement on the verb is because they are not sufficiently high in the structure. She argues that at the level of LF, they are internal to VP, and that this position is not local enough to T⁰ in order to allow semantic agreement to be possible, as would be expected from the discussion of *LF-visibility* above.

However, it is not the case that inanimate QNPs cannot control agreement on the verb. Glushan (2013) provides an important observation: inanimate QNPs *can* control plural (semantic) agreement, and in some cases must do. Firstly, when the QNP is the subject of a transitive clause, the inanimate/animate distinction seen in (259) breaks down, and both types of QNP can (optionally) control agreement on the verb:

- (260) a. Pjat' studentov polučili/polučilo stipendiju
 five students.GEN received.PL/received.N.SG scholarship
 'Five students received the scholarship.'
 b. Pjat' izdanij ?napečatali/napečatalo etu statju
 five volumes.GEN published.PL/N.SG this article
 'Five volumes published this article.'

More striking is what happens when the QNP is presupposed. In this instance, *iF* agreement with the QNP is obligatory, even for inanimate subjects:

- (261) **Context:** There were ten fridges selected for this dorm kitchen. They were used but supposedly in good shape. Five of them functioned, the other five were placed in the kitchen for storage.

Pjat' (iz etih) holodilnikov rabotali/??rabotalo, pjat' ostalnyh prosto
 five of these fridges worked.PL/workedNEUT.SG five of.the.rest simply
 stojali/??stojalo v kuhne na hranenii
 stood.PL/NEUT.SG in kitchen on storage
 'Five of these fridges worked, the remaining were kept the kitchen for storage.'

- (262) **Context:** There were ten people selected to be sent to a developing area N. They were all qualified engineers. Five of them worked at this plant, the other five worked in construction.

Pjat' (iz etih) inženerov rabotali/??rabotalo na etom zavode. Pjat' ostal'nyh
 five of these engineers worked.PL/worked.N.SG on this plant five of.the.remaining
 inženerov rabotali/??rabotalo v stroitel'stve
 engineers worked.PL/worked.N.SG in construction
 'Five of these engineers worked at this plant, the rest of the engineers worked at
 construction.'

Glushan, following Diesing (1992), argues that presupposition forces movement of the NP into Spec,TP, so that they can appear in the restrictive clause of logical structure. This brings them in line with the *LF-visibility* hypothesis. The contrast with presupposed and non-presupposed inanimate QNPs is especially striking: inanimate QNPs that would otherwise lie in the complement of VP do not allow for *iF* agreement, but when moved into Spec,TP, they do allow for *iF* agreement, exactly as we predict from *LF-visibility*.

In sum, the fact that *iF* agreement is obligatory when the QNP binds a reflexive or PRO, coupled with obligatory *iF* agreement when the QNP moves to Spec,TP with a presuppositional reading, provides independent support for the hypothesis of *LF-visibility*.

3.6.3 The optionality of *iF* agreement, and why Russian might pose a problem

Despite the initial observations in the section above that seem to show Russian conforming to *LF-visibility* as we would predict, the picture is a little more complicated. Russian, unlike English, allows for a variety of places where the subject can appear. In English, the subject largely lies in Spec,TP, however, Glushan motivates a number of different places for the subject, which all interact with the notion of animacy. Whilst Spec,TP is the position where presupposed subjects lie, non-presupposed subjects can lie in various other positions. Below I give an outline of the positions of subjects that Glushan proposes, coupled with the explanation in (264). It is important to bear in mind that the positions in (263) refer to *LF*-positions, and not necessarily overt positions.

(263)

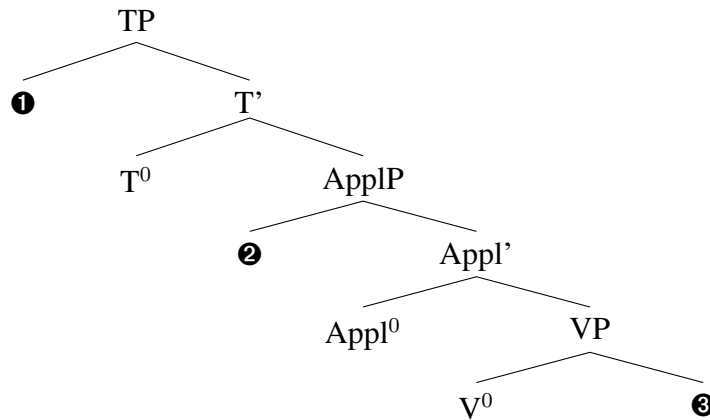

(264)

Type of QNP	Position	<i>i</i> F agreement	Example
Antecedent	❶	Obligatory	(257)
Presupposed	❶	Obligatory	(261), (262)
Transitive subject	❷	Optional	(260)
Animate intransitive subject	❷	Optional	(259a)
Inanimate intransitive subject	❸	*	(259b)

A few notes on the positions are in order. Glushan assumes that there presuppositional readings are only possible if the argument is in Spec,TP (*c.f.* Diesing 1992). Secondly, along with Franks (1995), she assumes that for binding of anaphors and control into gerunds is only possible from Spec,TP. Transitive subjects lie in Spec,ApplP, as do animate intransitive subjects. Finally inanimate intransitive subjects lie reconstruct into VP.

Glushan goes on to claim that this ‘middle’ position provides an explanation for why it is that *i*F agreement is obligatory for presupposed QNPs, but optional for animate QNPs that are not-presupposed. Glushan argues that a spec-head relationship leads to obligatory *i*F agreement with QNPs. Thus, QNPs which lie in Spec,TP are in a spec-head relationship with the agreeing head T⁰, and obligatorily control *i*F agreement on the verb.

Glushan further claims that *i*F agreement that results from a non-spec-head relationship is optional. Thus, QNPs that lie in Spec,ApplP do not lead to obligatory *i*F agreement, and in this way contrast with presupposed QNPs. The reason why spec-head relationships should lead to obligatory agreement is left open by Glushan. This middle position also forces Glushan to adopt a different view of the locality of semantic agreement than proposed here. She argues, along with the general line taken in this chapter, that semantic agreement obeys a different locality than *u*F agreement. *u*F agreement can see to a VP-internal position (as is claimed here), but agreement with an *i*F requires a different

configuration. Glushan appeals to the notion of agreement domains (Bobaljik & Wurmbrand 2005), and argues that semantic agreement has a domain of its own. As shown below, although *uF* agreement is possible with Theme arguments (see above), semantic agreement cannot reach that far. Thus, Glushan explains the fact that non-presupposed inanimate QNPs cannot control *iF* agreement, since *iF* agreement is restricted to domains that precludes the Theme position that they lie in:

(265)

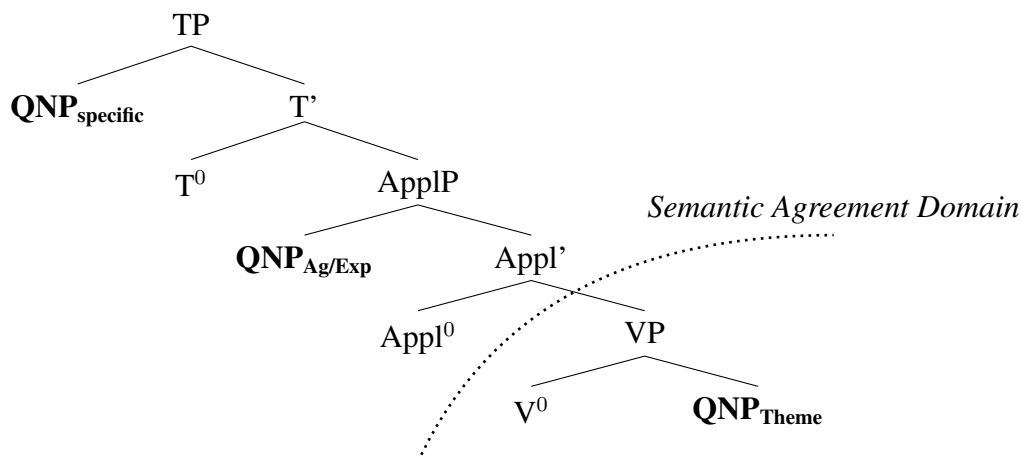

The idea is that semantic agreement is restricted to semantic agreement domains. If an argument lies outside of that domain, such as the complement to V^0 , then semantic agreement is not possible. The idea of domains specific for agreement is proposed elsewhere in Bobaljik & Wurmbrand (2005), but, as Glushan (2013) notes, that there are specific domains simply for semantic agreement is somewhat stipulative.

If Glushan's approach is the right way of looking at the data, then the hypothesis of *LF-visibility* seems to face a problem; semantic agreement is possible, albeit optional, in a position that does not c-command the target of agreement. Therefore, even though Glushan shows that Russian provides strong evidence for the claim given here that *iF* agreement obeys different locality restrictions than *uF* agreement (which, recall, can see into position ③), it is not restricted to a Reverse Agree configuration. In the next section, I provide a reanalysis of the Russian data, showing that there is an analysis whereby it conforms to what was proposed above in section 3.2.

3.6.4 Russian does conform to LF-visibility

As it stands, Glushan's proposal seems to pose a problem for the validity of *LF-visibility*. However, here I present an alternative analysis in line with it. Glushan argues for the existence of three positions of subjects in part because of how agreement is resolved.

iF agreement is obligatory in position ❶, optional in position ❷, and impossible in ❸. *iF* agreement is impossible in position ❸ since that position lies outside of a semantic agreement domain. Thus, the mechanism of semantic agreement is unable to see ❸. In positions ❶ and ❷, there is an obligatory/optional contrast, due to agreement being an instance of spec-head agreement in ❶, but not in ❷.

(266)

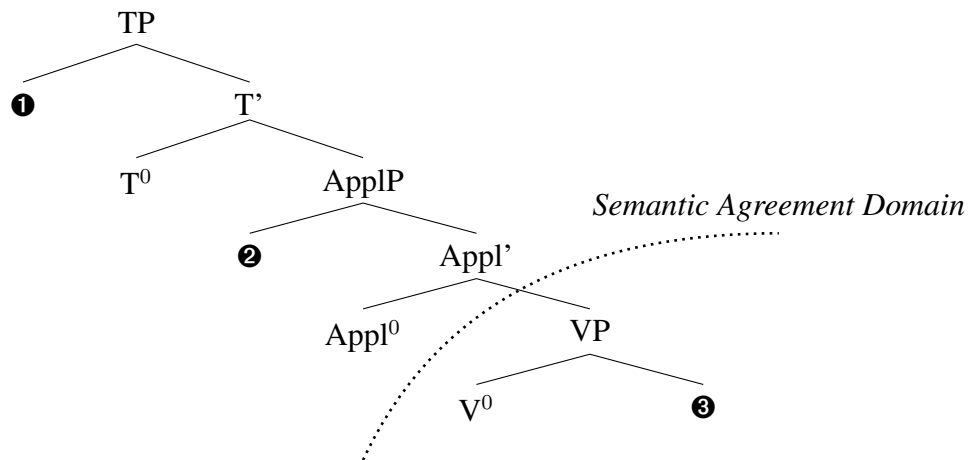

Glushan leaves open why it is that a spec-head configuration should lead to obligatory *iF* agreement, whilst it is optional otherwise. However, *LF-visibility* opens up another way of viewing Glushan's data. *LF-visibility* makes the prediction that semantic agreement should only be possible in Spec,TP, essentially redrawing the Semantic Agreement Domain above Spec,ApplP.

(267) Prediction of LF-Visibility

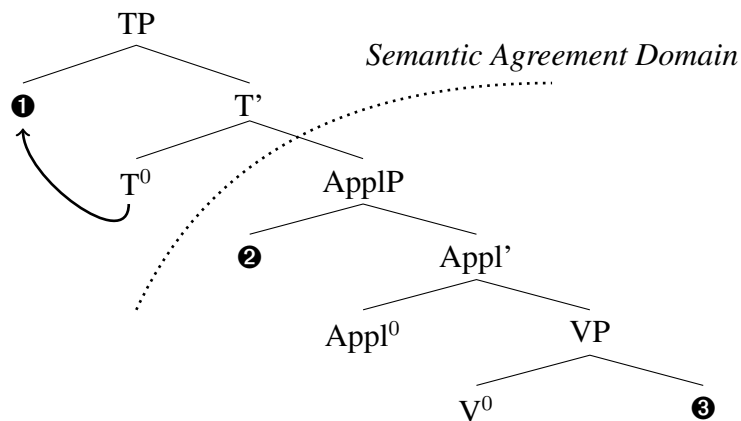

In the current approach, there is no option of position ❷ showing *iF* agreement, optional or not. As shown by Glushan, the difficulty comes from the optional nature of some types of QNP agreement. Whilst Glushan argues that the optionality comes from a difference between spec-head *iF* agreement and non-spec-head *iF* agreement, another way of looking at it is to assume that there is optional movement of the QNPs.

However, Glushan offers an alternative analysis (without committing to whether it is correct or not) which is in line with *LF-visibility*, which I adopt the spirit of here with some important qualifications. In the alternative analysis, optionality is derived through optional movement between Spec,ApplP / Spec,vP and Spec,TP, coupled with the assumption that whenever an element lies in Spec,TP, *iF* agreement is obligatory.

3.6.4.1 Preliminary assumptions

I propose that semantic agreement is obligatory for QNPs, in essence, because their *iF* is obligatorily active. That is, whenever the QNP controls agreement, it only does so with its *iF* feature. Furthermore, I assume that QNPs can optionally bear case, (this builds on a line of reasoning in Pesetsky 1982, Franks 1994, 1995, Bošković 2006a, Glushan 2013, but differs in the details). When they bear a case feature, they get valued by T for nominative case and control agreement. When they don't bear a case feature, they do not control agreement, and T agreement is default neuter singular. Now, we must further assume that a failure to copy an *iF* value under AGREE-COPY cancels the derivation:

(268) If AGREE-LINK has linked a goal with an active *iF*, AGREE-COPY must copy the value of the *iF* onto the goal.

This assumption will play a further role in section 4.5.5.2 below and will be discussed further there, as well as in section 3.6.4.5 following my analysis. For now I assume it for the present analysis and ask the reader to bear with me on this point.

3.6.4.2 Spec,TP leads to *iF* agreement

Now I turn to spelling out the analysis. Recall that I assume that at the first possible point in the derivation, T is merged and undergoes AGREE-LINK. This will create a link between it, and the DP/NP that bears nominative case. If the QNP bears a case feature, then it will control agreement on T, since it will come to have nominative case. As *iFs* on QNPs are always active by assumption, the link is forged between T and the *iFs* of the QNP. *Per* (268), the derivation can only converge in this instance if the value of the *iF* is copied to the unvalued feature, here on T. If the QNP lies beneath T, then the derivation crashes, since the necessary Reverse Agree configuration is not in place to allow the value

to be copied. Effectively, whenever a QNP has nominative case, the derivation can only converge if the QNP moves to Spec,TP.

However, since QNPs can also merge without a case feature, there is another option. If the QNP does not receive nominative case from T, then it does not control agreement on T, as T agrees with the nominative argument. If this is the case, the fact that its *i*Fs of the QNP are not copied to T does not cause a problem. In this instance, I assume that the 3.SG on the verb is default agreement, when a regular agreement relation cannot be established (Preminger 2011, 2015).

Thus, we are left with a dichotomy between in Russian between Spec,TP and everywhere else. In Spec,TP, agreement with a QNP is obligatory, due to the fact that the *i*Fs of the QNP are active. If the QNP lies anywhere else, then agreement with the QNP is not possible, since the value of the *i*F will not be able to be copied to T, crashing the derivation per (268). QNPs can remain beneath T only if T does not agree with the QNP, in which case we find default agreement on T.

3.6.4.3 Deriving the ‘optional’ movement through Last Resort

Key to the optional nature of agreement with QNPs is the fact that movement to Spec,TP is optional. Glushan (2013) notes this, but leaves the matter open as pure optional movement, and claims that it is conceptually undesirable to have optional movement (following Chomsky 1995 and most work within the Minimalist Program). It is my goal here to show that the optional movement is not really an optional movement, but rather distinct derivations.

Since QNPs that lie in Spec,vP are the ones that show optional agreement, let’s restrict our attention for the time being to these. Firstly, consider the following intransitive structure, where the QNP is animate and so lies in Spec,AppIP. Suppose that it has a case feature (annotated with +Nom). The QNP is animate, and so following Glushan (2013), I assume that it must lie in Spec,AppIP:

(269)

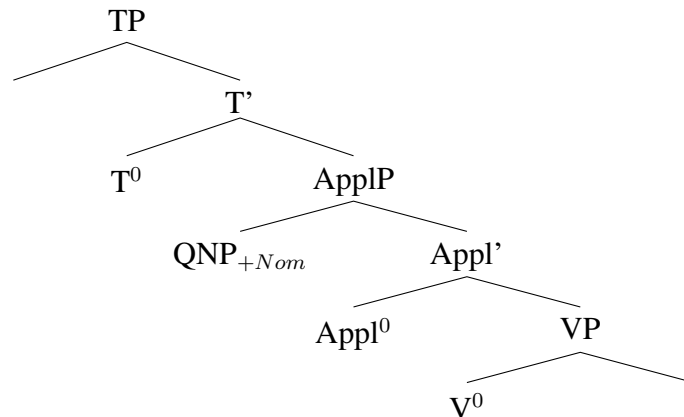

For this derivation, there are two options at this point; the QNP can move to Spec,TP or it can stay where it is. First, consider what happens if it remains in Spec,ApplP. The QNP has nominative case, and thus T will control agreement on the verb. In the derivation, AGREE-LINK will link T and the QNP. Since the *i*Fs of QNPs are always active in Russian, if the QNP remains in Spec,ApplP, the values of the *i*F will not be able to be copied to T, and so the derivation crashes. The second option is that the QNP moves to Spec,TP. If it does, its *i*Fs are able to be copied to T, and the derivation succeeds. The question is what forces the movement. Firstly, we cannot appeal to a traditional EPP to drive movement of the QNP. The status of the EPP in Russian is unclear. Though Lavine & Freidin (2001) and Bailyn (2004) argue that there is an EPP in Russian, which forces movement of some XP to Spec,TP, this will not help us here, since it would drag all QNPs to Spec,TP, and we would not be able to explain the differences between the different types of NPs.

Neither can we assume that QNPs move to Spec,TP in order to license a nominative case feature that they have, more in line with the EPP as it is assumed in English. This faces two problems. Firstly, nominative case can be licensed *in situ* in Russian, making any move to bidirectionally equate Spec,TP with nominative case suspicious. Furthermore, we again face the same problem that this ‘English-style’ EPP would treat all QNPs the same. The answer for the movement, I propose lies in Last Resort. I propose that the movement to Spec,TP is forced to save the derivation in (269). Without the movement to Spec,TP the derivation crashes. Following Bošković (2007) I assume that movement can be licensed in this case, thus the movement of the QNP is not optional here, but forced in order to allow the derivation to converge. After movement, the *i*Fs on the QNP are allowed to control agreement on T, and indeed must do so.

(270)

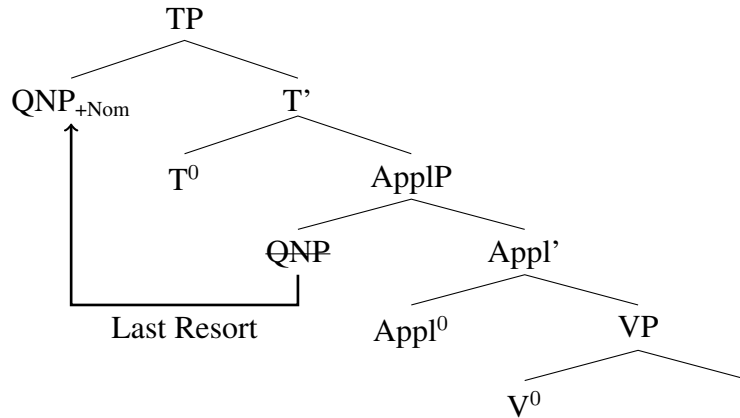

Now, consider the same structure as in (269) above, whereby the QNP is in Spec,ApplP, but does not bear a case feature.

(271)

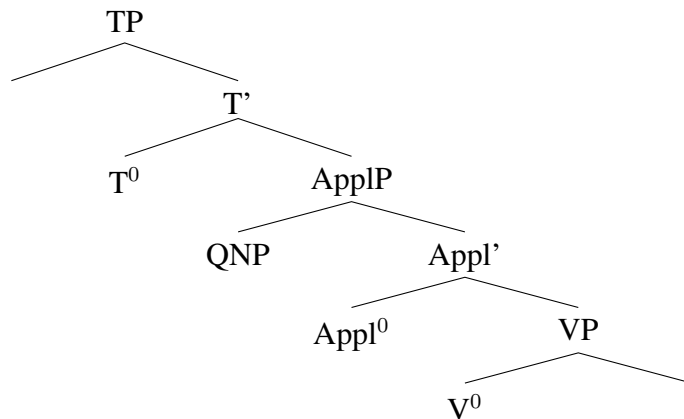

In this situation, the QNP can happily remain in Spec,ApplP, and as it does not bear nominative case, there is no link created between it and T through, AGREE-LINK. Since no link is created, it is not a problem if the *iF* values are copied to T.

In this manner, we derive the obligatory nature of *iF* agreement in Spec,TP, coupled with the observation that QNPs optionally control *iF* agreement. *iF* agreement is always obligatory when the QNP lies in Spec,TP, but movement to Spec,TP is happens only if the QNP bears a case feature. If it doesn't, it does not move to Spec,TP since there is no reason for it to move.

The issue that remains to be explained why it is only animates that allow for this optional movement to Spec,TP, and not inanimates. The difference between inanimate and animate QNPs is that the latter, but not the former are within the same phase as TP, since

they lie at the edge of the lower phase. It is thus then possible to analyze the movement between Spec,ApplP/Spec,vP and Spec,TP as being due to last resort, to save the derivation from crashing (Bošković 2007). Note that due to the fact that nominative can be assigned *in situ* in Russian, case considerations do not force the QNP to move in order to receive case. Thus, a QNP that merges as the complement of V will not move to Spec,vP in the derivation, unless that movement is triggered by something else. Movements that have an effect on interpretation can force it to move (Bailyn 2001) (hence presuppositional readings can be analyzed as the NP having some feature [F] which forces it to move to Spec,TP), as can other features standardly assumed to drive movement such as *wh*-features. In the absence of any of these, inanimate QNPs will remain VP internal.

In the above derivations, where Last Resort was appealed to to get the QNP to move to Spec,TP, the reason why the derivation would crash is because AGREE-COPY would otherwise fail to copy the features of the QNP to T if it links to it. However, this violation does not arise until the point at which T merges into the structure and undergoes AGREE-LINK with the QNP. If we follow the version of the Phase Impenetrability Condition offered in Chomsky (2000), then at the point at which T undergoes AGREE-LINK with a VP internal QNP, the QNP is frozen VP-internally, since nothing has forced it to move to the edge of the phase:

- (272) In a phase α with head H, the domain of H is not accessible to operations outside α , but only H and its edge.

A VP-internal QNP cannot then move to Spec,TP, even to save the derivation, as it cannot escape its phase at the point of the violation. Last Resort movement was allowed for the QNPs that are in Spec,vP/Spec,ApplP, as they were at the edge of the phase. This is schematized below:

(273)

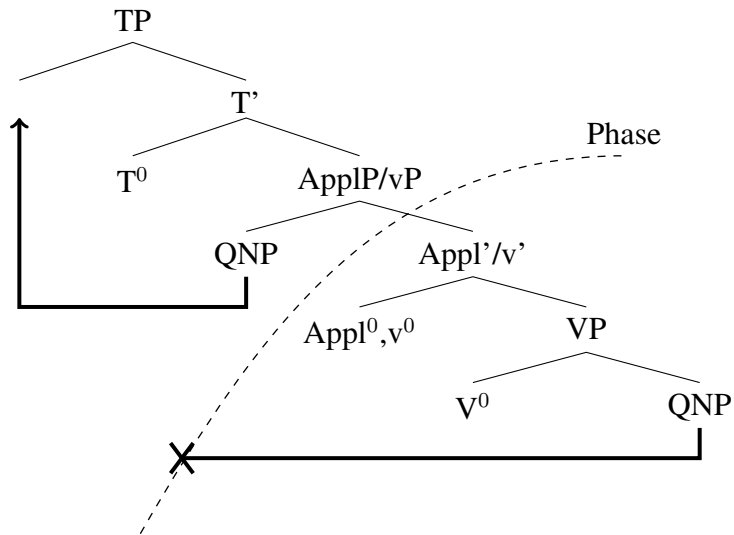

This has the consequence that a QNP that remains internal to the VP can *only* be the caseless version. If it were the version with nominative case, then the derivation can only crash due to the *i*Fs not being able to copy their value to T. Thus, the only way for the derivation to converge with an inanimate intransitive QNP is for a null expletive to be inserted in Spec,TP, and the QNP to be caseless.

(274)

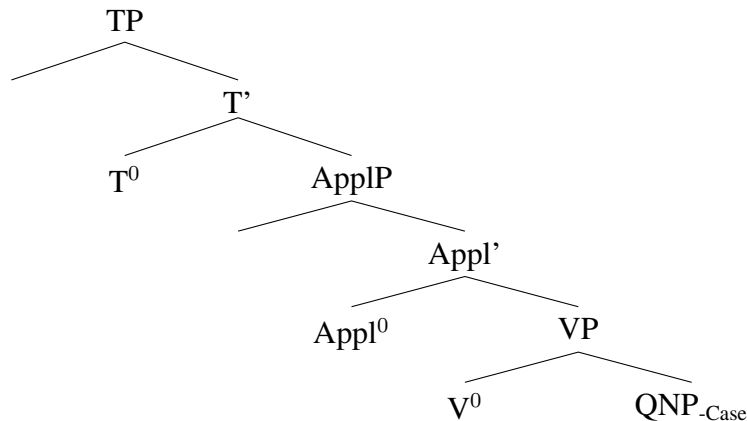

3.6.4.4 Derivations

In this subsection, I spell-out the derivations outlining the above. Firstly, consider the structure (275), where plural agreement (*i*F agreement) is licensed on the verb.

- (275) *Pjat' studentov prišli*
 five students.GEN arrived.PL
 'Five students arrived.'

In this structure, the QNP *pjat' studentov* moves from Spec,ApplP into Spec,TP because of Last Resort. If the QNP does not move to Spec,TP, the derivation is unable to converge, as the *i*Fs will be failed to be copied to T.³⁴

- (276)

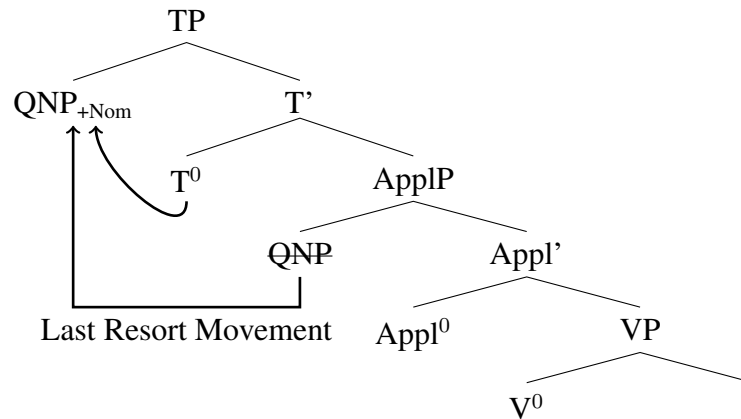

Secondly, consider the parallel case, but where default agreement is shown on the verb.

- (277) *pjat' studentov prišlo*
 five students.GEN arrived.N.SG
 'five students arrived.'

In this sentence, the QNP lacks nominative case, and is allowed to remain in Spec,ApplP. As there is no nominative argument, the verb fails to agree (Preminger 2011, 2015), since AGREE-LINK is not formed between T and a nominative element.

³⁴Note that the curved arrow in (276) indicates agreement.

(278)

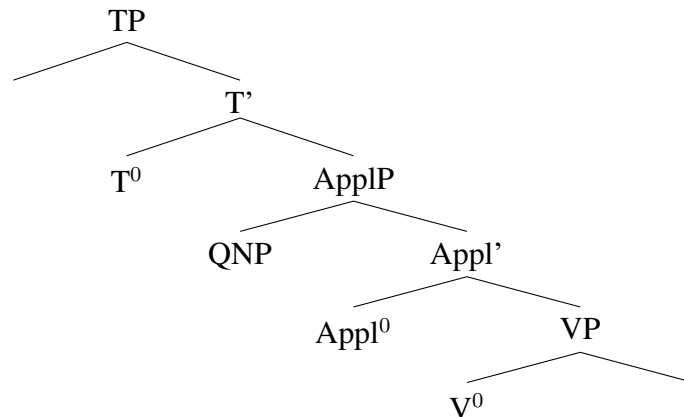

Now, consider a derivation, where the QNP is inanimate. The QNP is base generated in the complement of V (Glushan 2013), and does not move further. If it is generated with a case feature, T will link to it with AGREE-LINK. However, this will cause the derivation to crash, as the *i*Fs on QNP will not be able to be copied. However, if the QNP is caseless, the verb will fail to Agree resulting in default agreement on the verb, and the derivation can converge.

(279)

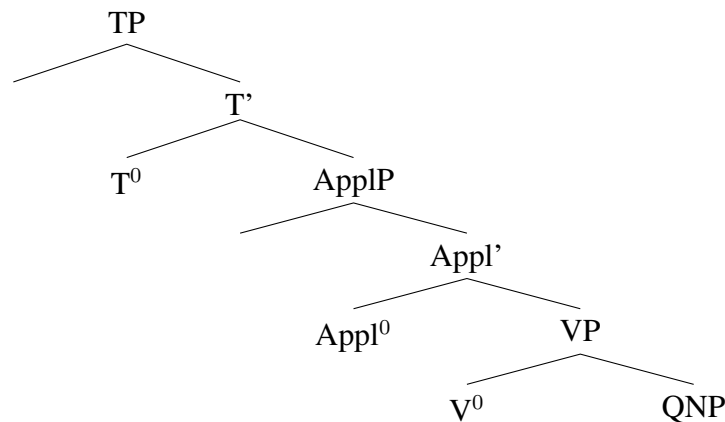

Finally, consider when an inanimate QNP has a presupposed reading. I will assume, following Glushan (2013), who in turn follows Diesing (1992) that this type of reading requires raising to Spec,TP. This requirement forces the QNP first to move to the edge of the phase, before moving to Spec,TP.³⁵

³⁵A problem which I leave open is why *i*F is apparently obligatory for all elements in Spec,TP. One might wonder what is stopping a caseless QNP appearing in Spec,TP and not controlling agreement, in which case

(280)

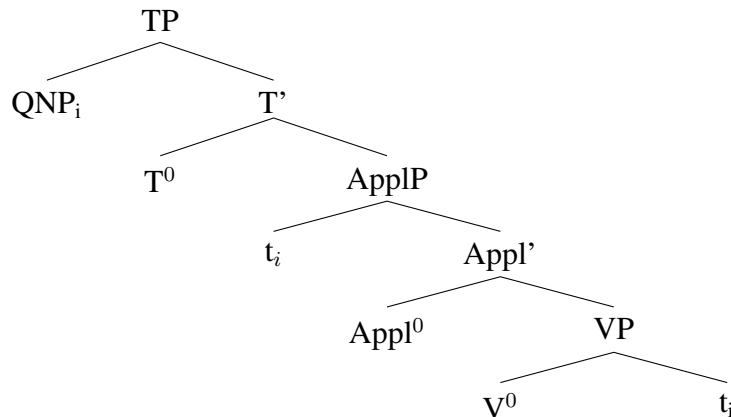

3.6.4.5 Against N.SG as μ F agreement

Before moving on from Russian, there remains one outstanding issue to be discussed, namely, why treat the plural agreement from QNPs as necessarily being i F agreement? For British English above, I proposed that CNPs are variable in allowing their i F to be active for agreement. Thus, we have a gradience in whether the CNP controls plural or singular agreement. However, for QNPs in Russian, I have proposed that their i Fs are always active. In other words, they must always give i F agreement, or not agree at all. This is surprising in itself, and I do not attempt to give an explanation for why this should be the case. However, it is worth backtracking slightly and seeing whether this is forced.

Another possible option would be to analyze QNPs as having a split on their number feature. They could be argued to be [i F:plural] but [μ F:singular,neuter].³⁶ Thus, the N.SG agreement on the verb would represent μ F agreement with the QNP rather than default agreement. Note that if we say that the N.SG agreement is μ F agreement, then we cannot adhere to (268), repeated below:

(281) If AGREE-LINK has linked a goal with an i F, AGREE-COPY must copy the value of the i F onto the goal.

If N.SG represents μ F agreement, we could maintain that the QNP controls i F agreement when it can, but N.SG when not. However, (281) is crucial to the account given

Spec,TP would remain the only position which can license i F agreement, but it is still optional there. One option is that nominative case must be assigned in Russian, and failure to have a nominative argument crashes the derivation. Thus, we could then say that if nominative case is not assigned, a null expletive is inserted into Spec,TP to absorb nominative from T. If we couple this with the assumption that there can be maximally one element in Spec,TP, then we get the effect that a QNP in Spec,TP must have case, and thus all agreement with a QNP in Spec,TP will target the i F. Whether this is correct I leave for further research.

³⁶Russian does not distinguish genders in the plural.

here, since it forces the Last Resort movement to Spec,TP. Without it, we lose any driving force for the movement to Spec,TP. This may not be so bad, and the movement between Spec,ApplP/Spec,vP might be genuinely free movement. If so, then all we need is the proposal that the *i*Fs on QNPs are always active.

However, as will be discussed in more detail in section 4.5.5.2 below, Russian does not allow an adjective to show *i*F agreement, whilst the verb shows *u*F agreement. This point in general will be discussed in much more detail in chapter 4, but for current purposes it suffices to note that whilst the agreement between the verb and the adjective does not match, the configuration where the verb shows *u*F agreement and the adjective *i*F agreement is not licit. This is shown by the following contrast. *Vrač* in Russian has masculine grammatical gender, but can refer to a female. Thus there is an *i*F/*u*F mismatch on the gender feature.

- (282) a. Po ulice šla novaya vrač
 along street went.FEM new.FEM doctor
 ‘Along the street went the new doctor.’
 b. *Po ulice šel novaja vrač
 along street went.MASC new.FEM doctor
 INTENDED: Along the street went the new doctor.’

However, when we look at QNPs, we see that an adjective can show plural agreement whilst the verb shows singular agreement (from Franks 1994):

- (283) Prišlo pjat’ krasivyx devušek
 arrived-N.SG five beautiful-GEN.PL girls-GEN.PL
 ‘Five beautiful girls arrived.’

As we will see in 4, if we were to relax (281), then we lose the ability to explain why (282b) is bad, but (282) is fine. Therefore, we cannot treat the N.SG agreement in QNP sentences as *u*F agreement of the QNP.

3.6.5 Interim Summary

In this section I have provided discussion of another case study of semantic agreement, and found that it broadly supports the ideas given in section 3.2. I have offered an analysis of QNP agreement in Russian, whereby *i*F agreement is only possible from Spec,TP position, in line with the proposal for English CNPs.

Russian gives strong support that there is a real difference between an agreement operation that targets an *i*F and one that targets a *u*F. That is, semantic agreement and morphological agreement are distinct in that semantic agreement requires a Reverse Agree configuration, whereas morphological agreement does not. Irrespective of whether this

potential reanalysis of the facts turns out to be viable, Russian still stands as an important example of the fact that *i*F agreement obeys different structural conditions than *u*F agreement.

3.7 Further support for the analysis: Conjunct Agreement

Further support for the view of Agree comes from conjunct agreement in English (Alexiadou et al. 2014) and potentially Hindi (Bhatt & Walkow 2013).

3.7.1 Conjunct Agreement in English

Alexiadou et al. (2014) note that agreement with conjoined DPs in existential constructions contrasts with agreement when the conjoined subject is a subject.

- (284) a. [A pirate and a knight] are/?is going to the party.
 b. There is/*are [a pirate and a knight] at the party.

These judgements are confirmed by the data in Sobin (1997), see also Schutze (1999). Sobin presents the results of a questionnaire survey on agreement patterns with a range of factors. What is relevant for us is the following:

(285)

Sentence	Score ³⁷
a. A cup and a napkin is on the table.	2.22
b. A book and a pen's on the desk.	2.69
c. A book and a pen are on the desk.	3.31
d. There is a pen and a stamp on the desk.	3.58
e. There's a book and a pen on the table.	4.36
f. There are a book and a pen on the desk.	0.81

Though the judgements are fuzzy for a conjoined preverbal subject, the relevant contrast is between (285c) and (285f), where the judgements are extremely clear. (285c) shows that agreement with &P is possible (and preferred over non-agreement), but agreement with &P when it is the associate of the existential construction in (285f) is not possible.

These data find a natural explanation in the current model of agreement.³⁸ It is commonly assumed (see Munn 1993) that conjunct phrases involve an asymmetric structure

³⁷ The scale ranges from 0 = completely unnatural to 5 = completely natural.

³⁸ Thanks to Susi Wurmbrand, p.c. for suggesting this analysis for the English data.

&P such that the first conjunct *c*-commands the second (this holds consistently across languages, on this, see among many others Munn 1993, Benmamoun et al. 2009). In addition to the features of the individual DP conjuncts, there are ‘resolved’ features on &P that come from the conjuncts. In a simple case like (284a), this means that because there are multiple instances of singular DPs in &P, &P as a whole has plural number. I assume that at least for English, &P has no *u*Fs of its own, but only *i*Fs that come from a resolution of the conjuncts.³⁹ The lack of *u*Fs in &P will be returned to below.

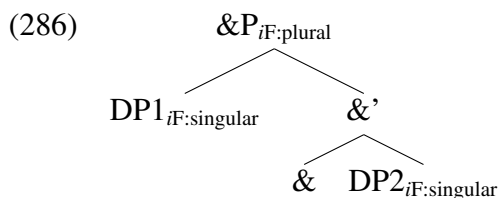

Since &P has only *i*Fs, we predict that it should only be able to be a controller of agreement when it lies above its target. This prediction is borne out, as shown by the contrast between agreements in (284) above (*c.f.* (285c) vs. (285f)). For (284a), &P is in Spec,TP at LF, and hence its [*i*F:plural] feature can license agreement on the verb. Thus, agreement is able to be plural. In contrast, in the existential construction in (284b) remains low. Therefore, agreement with the [*i*F:plural] feature is not possible. When agreement fails, the verb agrees with the highest DP in &P. Since the DPs within &P do have *u*Fs, they can serve as the agreement controller even when not in a Reverse Agree configuration with their target.

The structure for (284a) is as follows. We see that since the &P lies in Spec,TP, its *i*F:# feature is able to be agreed with.

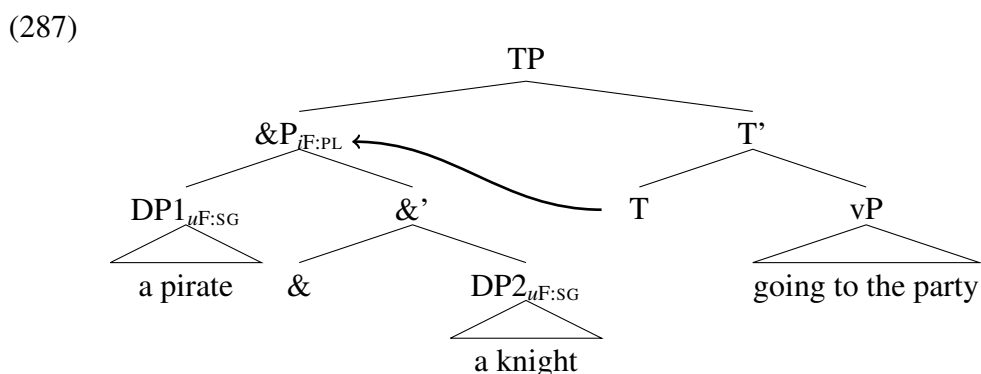

However, in the structure for (284b), we see that only *u*Fagreement with DP1 is possible, since the *i*F:# on &P does not *c*-command T.

³⁹I leave open the mechanism of this feature resolution.

(288)

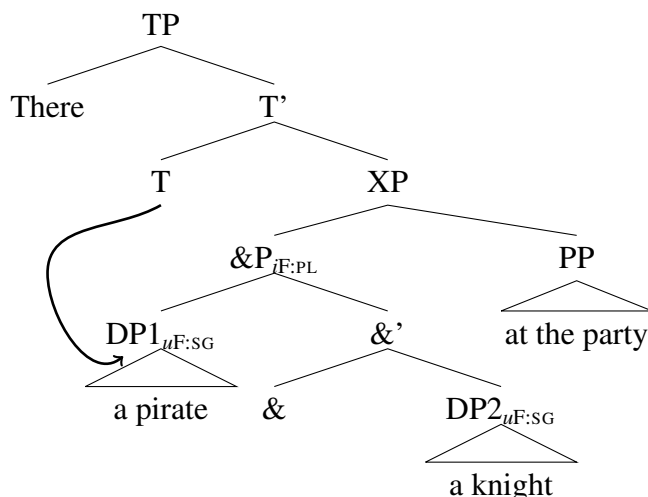

Before moving onto Hindi, it is worth considering further the question of whether there are uF s in $\&P$. This point is crucial to my analysis, since if there were uF s on $\&P$, the downward agreement in existential constructions should be able to see the uF s of $\&P$ and not reach the first DP. Furthermore, even if the uF remained unvalued, then we should expect that it would still be able to be agreed with. Whilst not a problem for (284a), as the result is correct, this would make the wrong prediction for when the first DP of $\&P$ is plural, which does control plural agreement in an existential (from Sobin 1997, with the average score indicated, see footnote 37 above):

(289) There are two cups and some plates on the table.

4.00

Now, it seems reasonable, at least in English to claim that $\&P$ has only iF s, since we never see any morphology that would indicate that they have a plural uF . For instance, in (284a), there is no plural suffix on any member of $\&P$. Another option, if one wanted to claim that there were uF s on $\&P$, would be to claim that the features of $\&P$ come from the features on the head *and*, which is inherently $iF:plural, uF:plural$. This would obviate the need for an independent mechanism of resolution since the features come from the head. *And* would need to be a portmanteaux spellout as in the following:

(290) [$\sqrt{AND, uF:plural}$] \Leftrightarrow and

Whilst the analysis does do away with the need for a mechanism of feature resolution in English as conjuncts can only be plural, in a language where a distinction is made between dual and plural, we get the wrong result. As shown in Marušič et al. (2015) for Slovenian, a [SG + SG] conjunct does give rise to dual agreement. Thus, it cannot be the

case that $\sqrt{\text{AND}}$ is always plural. One could then argue that there is also a dual variant of $\sqrt{\text{AND}}$, but then we independently need a mechanism of resolution anyway, that ensures [SG + SG] conjunct can only combine with [$\sqrt{\text{AND}}$ +dual]. One could then argue that there are two variants of $\sqrt{\text{AND}}$, that are accidentally homophonous. Whilst ugly, it could happen. However, once we take into account grammatical gender, which also resolves throughout conjuncts in languages that has it (see e.g. Bošković 2009b on Serbo-Croatian, Bhatt & Walkow 2013 and Marušič et al. 2015 on Slovenian, among many others for many other languages), we see that again, the form of *and* remains constant. I am not aware of a language that has different forms for *and* based on differing features of its conjuncts. Thus, we wind up with many, accidentally homophonous forms if &P has *u*Fs. For these reasons, I conclude that &P lacks *u*Fs altogether.⁴⁰

Now to return once more to the difference between (284a) and (289). We have seen that when &P lies in the subject position in English &P as a whole controls agreement, but when it is lower than T, the first conjunct is the controller of agreement. In order to derive the difference between the two, it is necessary that T is able to probe into &P and agree with the closest element, which should be blocked if it has a *u*F. Thus, I propose that &P lacks *u*Fs altogether, which allows T to look past the &P layer, and see the first conjunct. I have proposed above that *i*Fs can be active or inactive, and if active they control agreement. This in principle should carry over to &Ps. Since they lack *u*Fs, when their *i*F is inactive, we would expect that the first conjunct can control agreement even when &P lies in subject position. AGREE-LINK would link T to &P, but, given that the *i*Fs on &P are inactive they won't be linked to. Just as in existential constructions, T should then be able to look further into &P and agree with the first conjunct. I propose that this is correct. Consider again the data from Sobin (1997):

(291)

	Sentence	Score
a.	A cup and a napkin is on the table.	2.22
b.	A book and a pen's on the desk.	2.69
c.	A book and a pen are on the desk.	3.31
d.	There is a pen and a stamp on the desk.	3.58
e.	There's a book and a pen on the table.	4.36
f.	There are a book and a pen on the desk.	0.81

⁴⁰In chapter 2, I proposed that fake mass nouns control singular agreement, by default: true agreement is not possible because they cannot receive a *u*F value due to their inherent *i*F. However, it is clear that with &Ps the lack of *u*Fs does not always lead to default agreement. The difference between the two, I suggest, is that with &P there are alternate DPs within &P that can be agreed with. Thus, AGREE-LINK can look deeper inside &P to find a target. This option is presumably unavailable with fake mass nouns because they do not contain anything further - the DP is the only thing that can be agreed with.

We see from the (a) and (b) examples in the table that singular agreement is possible, albeit degraded. The singular agreement cannot have come from &P, which is plural. Furthermore, it is unlikely to be an effect of agreement attraction, since the second conjunct *a napkin* is singular. As shown by Eberhard (1997), singular DPs do not generally give rise to agreement attraction effects. It seems reasonable then to assume that the singular agreement in the (a) and (b) sentences has come from the first conjunct.⁴¹ If this is the right way of looking at the data, then the contrast between (a) and (b) sentences and (f) is notable, as (f) represents the agreement I disallow, namely where T agrees with the *i*Fs on an &P that it c-commands. But in principle, (a) and (b) should be allowed.

3.7.2 A further possible extension: Hindi

To the extent that the above analysis is on the right track, we can see the same phenomenon in Hindi.⁴² Bhatt & Walkow (2013) show that conjunct agreement differs in Hindi depending on whether the conjunct is the subject or object of the sentence. When the conjunct is the subject, then we see resolved agreement on T.

- (292) Ram aur Ramesh gaa {rahe hãĩ / *rahaa hai}
 Ram.M and Ramesh.M sing {PROG.M.PL be.PRS.PL / *PROG.M.SG be.PRS.SG}
 ‘Ram and Ramesh are singing’

However, when the conjunct is the object, and controls agreement, we do not see resolved agreement, but rather CCA:⁴³

- (293) a. Ram-ne ek thailii aur ek baksaa (aaj) uṭhaa {-yaa / *-yii / ???-ye}
 Ram-ERG a bag.F and a box.M (today) lift {-PFV.M.SG / *-PFV.F / ???-PFV.M.PL}
 ‘Ram lifted a small bag and a box.’

⁴¹Another option is that this reflects default agreement when *i*F agreement doesn’t happen.

⁴²Bhatt & Walkow (2013) give a different analysis of the contrast between conjoined subjects and conjoined objects in Hindi. In brief, their analysis is that ν probes the object &P, inactivating its ϕ -features and preventing T from undergoing full agreement with that ϕ set in the syntax. However, T is able to match with &P, creating a link with it. In the post-syntax, T is able to look into T and value its ϕ -features from the (linearly) closest argument. For subjects however, they are never probed by ν , and so their features are active at the point of T agreement, and so able to undergo full ϕ -agreement with T in the syntax. I do not present my analysis here as superior over theirs, nor do I know of any reason empirically why their analysis should fail. All I wish to point out is an alternative way of looking at their facts that finds an exact parallel in English. To the extent that unifying two clearly phenomena under the same umbrella is to be preferred, then it seems like a path worth exploring.

⁴³The subject does not control agreement in these examples because it is marked for ergative case. Agreement in Hindi is controlled by the highest argument not marked for case, see Bhatt (2005), Bobaljik (2008).

- b. *Mona-ne bazaar-me dekh-aa th-aa ek ghoṛaa aur kai*
 Mona-ERG bazaar-in see.PERF-M.SG be.PST-M.SG a horse.M.SG and many
kutte
 dogs.M.PL
 ‘Mona had seen a horse and many dogs in the market.’

The precise mechanism of CCA is derived is not immediately relevant for our purposes, but what should be taken away from (293) is that resolved agreement is not possible. We can appeal to the same explanation as above in order to account for the distinction between subjects and objects. Assuming that subjects in Hindi lie in Spec,TP (Anand & Nevins 2004), and objects are within *v*P, then we see that resolved agreement is possible with the subject because the *i*Fs on &P are visible for agreement, but the *i*Fs on the object are not.

The explanation is that when the conjunct lies in Spec,TP, the *i*Fs on &P are visible for agreement. However, when the position of &P is low, because it is an object, then we see that *i*F agreement with &P is not possible. On the assumption that &Ps have only *i*Fs, then we derive the difference between the two. Note that if the Hindi facts are to be treated in the same way as the English facts, then it provides an argument in favour that AGREE-LINK can happen in the derivation in a non Reverse Agree configuration, but it is the AGREE-COPY mechanism that is subject to Reverse Agree.⁴⁴ The minimal difference between the two languages is that AGREE-COPY in the postsyntactic component happens before linearization in English and hence only pays attention to hierarchical relations, but after linearization in Hindi, and so linear relations can play a role.

3.8 Conclusions

In this chapter I have had a number of primary goals. Firstly, this chapter has further supported the division of features into *i*Fs and *u*Fs through looking at the different ways in which agreement processes target them. This has led into a discussion of the properties of semantically motivated agreement and how it relates to morphologically motivated agreement. We have seen evidence from British English and Russian (and to a lesser extent Hindi), that agreement targeting the *i*F of a controller obeys different restrictions than agreement that targets a *u*F. This finding is surprising if viewed from the perspective that all agreement happens in a single manner, for instance downwards within the syntax. I proposed that semantic agreement is possible only in a Reverse Agree configuration. This ‘upwards only’ restriction is the result of *i*Fs necessarily being targeted within the syntax, coupled with syntax only looking upwards, and only at the point of transfer. That semantic

⁴⁴See discussion in footnote 19 above.

agreement is only possible in this configuration will be exploited in the next chapter where I take a close look at mismatches between *i*F and *u*F agreement.

There is a further consideration regarding the nature of agreement that I leave open for future work. In this chapter I have presented a proposal on the nature of Agree whereby AGREE-LINK operates within the syntax, linking two elements together. AGREE-COPY then copies the values of the features that are linked to the target by AGREE-LINK. It seems worthwhile to take stock and consider an alternative. Another way of looking at the data would be to assume that there are two types of Agree:

- (294)
- a. Syntactic Reverse Agree, which happens in the syntax and operates when some form of *i*F is implicated in the process. The controller must c-command the target.
 - b. Post-syntactic Agree, which works as Bobaljik (2008) proposes, where ϕ valuation happens bidirectionally looking at the entire Infl+V complex along the PF branch.

This is broadly the line pursued in Wurmbrand (2012a) and Smith (2013). This model of agreement is similar to what is proposed here but differs in important ways. *i*Fs will only be able to be agreed with if they lie above the target of agreement, whereas *u*Fs will be able to be agreed with in both ways. One difference is that whilst there are two components to AGREE, it is literally two different AGREEmechanisms, rather than a domain difference. The result is that agreement that targets *i*F must happen in a Reverse Agree configuration, as *i*Fs will not exist on the PF-branch. If we couple this with the assumption that syntactic AGREE (294a) happens at the point of transfer, then we are left with the effect that *i*F agreement is possible only when the controller c-commands the target at LF. As far as I can see, if we adopt this model of AGREE for British English, the results remain the same.⁴⁵ Furthermore, it seems possible to gain a partial analysis of Russian in this way: movement to Spec,TP of the QNP will feed *i*F agreement because it creates a Reverse Agree configuration.⁴⁶ Such an analysis seems even more desirable for Russian, given what I propose about how AGREE-COPY treats *i*Fs.

- (295) If AGREE-LINK has linked a goal with an *i*F, AGREE-COPY must copy the value of the *i*F onto the goal.

(295), which looks somewhat clunky in the approach advocated for here, falls out nicely assuming (294), since Reverse Agree immediately copies the features. Thus, if

⁴⁵Indeed, in previous work I have advocated for it, see Smith (2013).

⁴⁶This would have to be supplemented by some condition that forces *i*F agreement wherever it is possible in Russian.

couple this approach with the assumption that *i*Fs are always active on QNPs in Russian, we find that *i*Fs must always be agreed with if they can. Empirically, I don't see anything in the data discussed so far to decide between the two approaches. Furthermore, I do not see any conceptual arguments to favour one view over the other. One could argue that the reformulation allows for a simpler view of syntax, than what is advocated for here. In what I have discussed above, I propose that there is a slightly dual character of syntactic operations, in that AGREE-COPY can only look upwards in the narrow syntax, but AGREE-LINK can look both upwards and downwards. The alternative analysis arguably is stronger in saying that the only operation within the syntax is Reverse Agree, thus there is no bidirectionality. This is true, and is probably stronger than what I claim here. What I claim is not inconsistent with this view however; it is possible to restate my approach in a syntax-only-looks-upwards view, where AGREE-LINK can only look upwards in the structure. The main arguments for downward looking agreement must then be analyzed as involving covert movement of the controller to a position above the target. To my mind, the most convincing cases that syntax can look downwards come from agreement with nominative objects, and long-distance agreement, exemplified in Icelandic and Tsez respectively:

- (296) Um veturinn voru konunginum gefnar ambáttir. [Icelandic]
 In the.winter were.PL the.king.DAT given slaves.NOM
 In the winter, the king was given (female) slaves.
- (297) enir užē magalu bāc'rufi b-iyxo [Tsez]
 mother boy bread.III.ABS ate III-know
 'The mother knows the boy ate the bread.'

Indeed, there have been analyses of these phenomena that are in line with a Reverse Agree configuration of agreement. For Icelandic, Koopman (2005) argues that in Icelandic there is a Reverse Agree configuration between T and the nominative object, and Chandra (2007) argues that the long-distance agreement facts involve covert movement of the absolutive to the main clause. To the extent that these analyses are correct, then we can make the conceptually stronger statement that all Agree operations that happen within the narrow syntax look upwards. I leave this matter open for future research. For now I stick with the slightly weaker version where AGREE-LINK looks both upwards and downwards in the syntax. Conceptual issues aside, I do not believe that it matters too much for our purposes. Returning to the discussion of my mechanism for agreement versus the other, in the following chapter, we will see further evidence for AGREE as I propose it, where AGREE-LINK happens cyclically throughout the derivation, and AGREE-COPY is evaluated at transfer. This provides further support for treating Agree as a two-step oper-

ation, rather than a single-step operation that happens in two places, contrary to what was proposed in Wurmbrand (2011, 2012a) and Smith (2013).

Chapter 4

The Agreement Hierarchy

This chapter builds on the work in chapter 3 by investigating how semantic and morphological agreement interact. Recall from the earlier discussion that we need to distinguish between morphologically based agreement, which was analyzed as agreement that targets the uF value of a feature, and semantically based agreement, which targets the iF value of a feature. Much of the discussion in chapter 3 centered around situations where the agreement value on one target was either semantically motivated or morphologically motivated. However, as will be discussed below, in cases where there are two potential targets for agreement, there is the possibility of mismatches between the two targets where one targets the iF and the other targets the uF . As we will see, what is interesting about these cases is that the possibility of mismatches seems to interact with the Agreement Hierarchy of Corbett (1979).

4.1 The typology of morphological versus semantic agreement

4.1.1 The Agreement Hierarchy

Work by Corbett (Corbett 1979, 1983, 2000, 2012) on the prevalence of semantic and morphological agreement in different languages has established that even though a language allows for either semantic or morphological agreement, it is not always a straight choice between the two for all elements. Corbett establishes the Agreement Hierarchy, which states that for elements that can show alternating agreement between morphologically motivated agreement and semantically motivated agreement, certain agreeing elements are

more or less likely to show semantic agreement than morphological.¹

- (298) attributive — predicate — relative pronoun — personal pronoun
 ←-- morphological agreement semantic agreement --→

Elements to the right on the hierarchy are more likely to show semantically motivated agreement, whereas elements to the left are more likely to show morphologically motivated agreement. One important aspect of the hierarchy is that one can formulate implicational statements based off it. Corbett notes that the likelihood of semantic or morphological agreement for elements increases monotonically along the hierarchy. Thus, if for a given element in the hierarchy, some position shows the possibility of semantic agreement, all positions to the right will also allow for semantic agreement, at least at an equivalent frequency. Conversely, if an element on the hierarchy allows for morphological agreement, so will all elements to its left on the hierarchy at least at an equivalent frequency.

These implications can be seen in various languages. Corbett (1983) gives the example of Polish titles, which have the form of being non-masculine, but can refer to males. These nouns generally have non-masculine agreement for any agreeing elements in attributive position, yet all other elements can show masculine agreement:

- (299) Wasza Królewska Mość, który wie więcej od nas, musiał
 your.FEM kingly Majesty who.MASC knows more than us must.have.MASC
 wiedzieć o tym. Niech on nam wytłómaczy
 known about this. Let him.MASC to.us explain

As we will see below, certain cases of mismatches seem to obey the Agreement Hierarchy, with one of the mismatches apparently ruled out by appeal to it. We can formulate this as an implicational rule:

- (300) *3/4 Implicational Rule*
 When a controller controls agreement on two targets, the value assigned to the two targets can mismatch only if among the targets, the element which is to the right on the agreement hierarchy agrees with the *iF* of the target and the element to the left on the hierarchy targets the *uF* value.

Levin (2001) gives a thorough overview of the agreement patterns of collective nouns in English, and how this distribution relates to Corbett's hierarchy. Recall from chapter 3

¹Corbett uses the term 'syntactic' agreement where I use 'morphological' agreement. The terminology does not matter, and I use 'morphological' agreement for consistency with the rest of this thesis.

that collective nouns in English uniformly control singular agreement on targets that agree with them. However, plural agreement is allowed also, albeit not by all speakers, and always in a more restricted manner:

- (301) a. The government **is** trying to counter the domestic threat from ISIS.
 b. %The government **are** trying to counter the domestic threat from ISIS.

Levin looks at various corpora of spoken and written English, across three dialects. One of the crucial insights, which mirrors Corbett's original proposals is that the Agreement Hierarchy is manifested in English in an entirely gradient manner. What this means is that the hierarchy remains stable, even when the absolute frequencies of semantic and morphological agreement go up and down. For instance, within a single dialect, Levin shows that the register of the language used has a major impact on how likely semantic agreement is. Consider the figures below, given by Levin for British English. The data on written English come from *The Independent* newspaper, whilst the spoken data come from the British National Corpus:

(302)

	Independent				BNC			
	Singular		Plural		Singular		Plural	
	N	%	N	%	N	%	N	%
Verbs	2260	77	683	23	1414	68	671	32
Relative Pronouns	417	59	293	41	115	42	162	58
Personal Pronouns	477	44	616	56	170	28	437	72

In the table, we can see that the rate of semantic (plural) agreement increases in spoken register compared to writing. What is interesting is that the numbers reflect the hierarchy irrespective of the register. In both written and spoken English, we see that personal pronouns have a higher frequency of plural agreement than relative pronouns, and both in turn have a higher frequency than verbs. The same pattern is seen in American English, though the frequency of plural agreement remains lower overall:²

²Aside, curiously, from relative and personal pronoun agreement in spoken American English, which are both higher than in British English.

(303)

	New York Times				LSAC			
	Singular		Plural		Singular		Plural	
	N	%	N	%	N	%	N	%
Verbs	3149	97	84	3	476	91	48	9
Relative Pronouns	537	76	165	24	11	426	32	74
Personal Pronouns	941	68	442	32	14	6	225	94

Levin also shows a comparison between three different dialects of English. British English most freely shows plural agreement with American English the least free. Australian English lies in between the two:³

(304)

	AmE				BrE				AusE			
	Singular		Plural		Singular		Plural		Singular		Plural	
	N	%	N	%	N	%	N	%	N	%	N	%
Verbs	3149	97	84	3	2260	77	683	23	1890	90	216	10
Rel Pron.	537	76	165	24	417	59	293	41	367	74	131	26
Per pron.	941	68	442	32	477	44	616	56	457	61	289	39

4.1.2 Lexical variation, and what is able to show semantic agreement

Before returning to the hierarchy, a note is in order about what can and cannot show semantic agreement.

Throughout this dissertation I have considered the consequences of there being both *i*Fs and *u*Fs that make up features. *i*Fs play a role in interpretation, however under certain circumstances, they are also able to play a role in agreement. However, a question that remains is *which* *i*Fs are available for agreement. We know that not every language shows *i*F agreement. And within a language, there are differences about which targets can show *i*F agreement.⁴ But there is a further complication, in that not all controllers allow for *i*F agreement. This can be seen in British English quite easily. British English does allow for semantic agreement, as shown with CNPs. However, semantic agreement is not easily allowed with Imposters or fake mass nouns. There cannot then be a blanket availability of semantic agreement according to language.

We can see this in the following examples. In (305) we see that a CNP licenses both singular and plural agreement, which is controlled by the *u*F and the *i*F of the noun respectively. In (306), things are different. The agreement on the verb is only able to be singular.

³The data in the table come from *The New York Times* (AmE), *The Independent* (BrE) and *The Sydney Morning Herald* (AusE), all representing high-level written registers of the different dialects.

⁴Recall that demonstratives in British English can never show semantic agreement with a CNP.

This does not represent *uF* agreement (but rather default), since fake mass nouns lack a *uF* specification in English. However, they do have an *iF*:plural specification. But agreement cannot target the *iF*, as shown in (306b). A similar story comes from the Imposter construction in (307) (Collins & Postal 2012). Here, *this supporter* is used as a third person DP, but the referent is first person. Thus, there is a mismatch in the person feature of the DP, it is *uF*:third, but *iF*:first. We see again that agreement can target the *uF* of the DP but not the *iF*.

- (305) a. The government is debating the bill.
 b. The government are debating the bill.
- (306) a. The furniture is looking shabby.
 b. *The furniture are looking shabby.
- (307) a. This supporter is optimistic for next season.
 b. *This supporter am optimistic for next season.

If it were the case that *iFs* are always active for agreement in British English then we would expect both (306b) and (307b) to be grammatical, contrary to fact.

The question which elements allow for *iF* can be settled by appeal to natural classes. Let's suppose that the default for agreement is to target the *uF* value of an feature. However, certain nouns allow for their *iF* to be active in the derivation, by which I mean that it is visible for agreement:

- (308) If an *iF* is *active* in a derivation, it is able to enter into AGREE-LINK.

Having active *iFs* is a prerequisite for an element to show semantic agreement. With this in mind, we can say that only certain elements allow for their *iFs* to be active, the set of which varies from language to language. In English, it is not the case that all nouns allow for *iFs* to enter into agreement, otherwise we would expect both Imposter constructions and fake mass nouns to show semantic agreement. It seems then that only CNPs in English allow for their *iFs* to be open for agreement. The set of nouns in a particular language that allows *iFs* to be active will need to be learnt during the process of acquisition. I do not have much to say here on this issue, other than to say that natural classes can presumably aid this process. For instance, a learner of British English needs to figure out that if a noun is a CNP, then it is able to make its *iFs* active. For other languages it could be the case that all nouns allow for *iF* agreement.⁵ Further still we might expect a language to show semantic agreement for Imposter constructions.⁶ A full typology of which classes

⁵Bear in mind that *iF* agreement is only detectable in case the *uF* and *iF* match.

⁶This is arguably shown with Unagreement, discussed in Höhn (2012) (see also references therein).

show semantic agreement in which languages is clearly an interesting question worthy of attention, however, I leave this for future research.

Note that lexical variation is more complicated than which class of nouns allow for their *iF* to be active or not. Within each class, we see differences in the frequency for which nouns undergo semantic agreement. Levin (2001) shows that among English CNPs, some are more likely to appear with semantic agreement, and some more likely to appear with morphological agreement. The following table (adapted from Levin 2001) shows the frequency of certain nouns in different dialects of English to appear with singular agreement:⁷

(309)

	NYT	Ind	SMH
81-100%	army audience commisstion committee family	association commission company department party	army audience club council government
41-80%	majority	band crew family minority	crew majority press public
<40%	clergy couple	couple majority staff	couple staff

There are thus two issues in lexical variation: (i) which controllers make their *iF*s active for agreement; and (ii) which targets allow for *iF* agreement. Why nouns vary in this way is also an interesting question, and I do not have anything more interesting to say that within a class of nouns that allow for semantic agreement, certain nouns make their *iF* active more regularly than others. Why this should be the case is another issue for another day.

I postpone discussion of the second question - which targets can show *iF* agreement until section 4.5.2 below.

⁷As in the above tables, NYT = New York Times = Written American English, Ind = The Independent = Written British English, SMH = Sydney Morning Herald = Written Australian English.

4.2 3/4 patterns

Corbett's hierarchy stands as an important observation when looking at morphologically motivated versus semantically motivated agreement. Corbett (1979, 1983) however states that the hierarchy is a typological generalization that simply predicts how likely a given element in a language is to show semantic or morphological agreement, relative to other elements in that language.

The Agreement Hierarchy is of interest to us here since it seems to interact with the question of mismatching agreements. In chapter 3, we saw evidence that the information stored on a single feature can mismatch between its semantic value and its morphological value; for instance collective nouns like *committee* were shown to be morphologically singular but semantically plural. This is in fact the strongest evidence that shows features to be split into two halves. Briefly discussed in that chapter is the fact that multiple elements that agree with hybrid nouns can mismatch their values. Thus, in British English we saw that with CNPs, verbs can agree with the *i*F and become valued as plural, demonstrative elements must show agreement with the *u*F, and be singular. When these two combine, we are left with a mismatch:

(310) This government are so much worse than what we had previously.

Similarly, Wechsler & Zlatić (2003) show that mismatches exist in Serbo-Croatian, shown below where the noun *deca* 'children' controls F.SG agreement DP internally, but N.PL agreement on verbal elements:

(311) Ta dobra deca su doš-l-a
 that.F.SG good.F.SG children AUX.3PL come-PPRT-NT.PL
 'Those good children came.'

Given that there is nothing against mismatches then, with all else being equal, we expect that when the controller of agreement is a hybrid noun, and there is more than one target of agreement, we predict the following agreement configurations to be possible:

(312)

Target 1	Target 2	Result
<i>u</i> F	<i>u</i> F	Matching morphological agreement
<i>i</i> F	<i>i</i> F	Matching semantic agreement
<i>u</i> F	<i>i</i> F	Morphological – semantic mismatch
<i>i</i> F	<i>u</i> F	Semantic – morphological mismatch

However, in many cases, what is found is that the full array of possibilities is not attested. Instead, we find just three out of the predicted four to arise, with the fourth option

markedly degraded. As will be discussed in the rest of this chapter, these 3/4 patterns come in two types. The first type of 3/4 pattern seems to reflect the hierarchy if it were operative within a single sentence, the second type does not.

4.2.1 Hierarchy based 3/4s

Let's suppose that there is some condition underlying the Agreement Hierarchy, and that it also holds within a single sentence. In addition to the sentences where the agreements match, we also expect that a mismatch between the two targets can arise if it is the element to the right on the hierarchy that shows semantic agreement, and the element to the left that shows morphological agreement. However, the converse mismatch would not be predicted to exist, leading to a 3/4 pattern. Here I will discuss three cases of this.

4.2.1.1 British English

The first case is from British English. As shown in the following paradigm, when there is an anaphor and a verb/auxiliary that agrees with the CNP, there is predictably no problem if the values on the two targets of agreement match. Thus, both (313a), with matching *u*F agreement, and (313b), with matching *i*F agreement are grammatical. When the two targets mismatch, the sentence where the verb targets the *u*F but the anaphor targets the *i*F is acceptable (313c), however, the converse mismatch is sharply degraded (313d):

- (313) a. The government has offered itself up for criticism (with this policy).
 b. The government have offered themselves/each other up for criticism.
 c. The government has offered [?]themselves/each other up for criticism.
 d. *The government have offered itself up for criticism.

Huddleston & Pullum (2002) note a similar pattern, however this time with possessive pronouns:⁸

- (314) a. The committee hasn't yet made up its mind.
 b. The committee haven't yet made up their mind.
 c. The committee hasn't yet made up their mind.
 d. *The committee haven't yet made up its mind.

⁸This is an exact parallel to the data given in (313), however there is controversy over whether possessive pronouns, being in attributive position should be treated as genuine syntactic anaphors, and hence entering into a binding relation with their antecedent, see for instance Pollard & Sag (1992). The anaphors in (313) above are unambiguously genuine anaphors.

However, it should also be noted that there is some controversy over the pattern. Polard & Sag (1994) give data showing that with collectives, only matching agreements between the verb and pronoun are acceptable. The judgements in (313) have however been checked against at least 10 speakers of dialects allowing for both plural and singular agreement, and whilst there is a little degradation when using *themselves* in (313c), the sentence is markedly more acceptable than (313d), and there is a strong contrast between the two.

4.2.1.2 Russian

A similar case comes from Russian, given in Corbett (1983). In this instance, the controller of agreement is the noun *vrač* ‘doctor’. *Vrač* potentially has a mismatch according to gender. The noun has masculine grammatical gender, however when the referent is a female doctor, gender agreement can reflect the semantic gender, feminine.⁹ Thus *vrač*, when referring to a female doctor, will be analyzed in the current terms as follows:

(315)

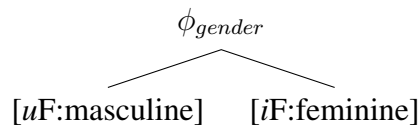

When there are two targets, here the adjective *novyj* ‘new’ and the verb *skazal* ‘said’, we again see three out of the four predicted patterns arising. The two targets can match in gender according to the *uF* value (316a) or match according to the *iF* value, (316b). Similarly, they can mismatch if the adjective agrees with the *uF* and the verb agrees with the *iF* value (316c). The converse mismatch however is not possible, where the adjective agrees with the *iF* value, and the verb agrees with the *uF* value:

- (316) a. *Novyj vrač skazal.*
 new.MASC doctor said.MASC
 ‘The new doctor said.’
- b. *Novaja vrač skazala.*
 new.FEM doctor said.FEM
 ‘The new doctor said.’
- c. *Novyj vrač skazala.*
 new.MASC doctor said.FEM
 ‘The new doctor said.’

⁹If the referent of *vrač* is a male, then there is no gender mismatch.

- d. *Novaja vrač skazal.
 new.FEM doctor said.MASC
 ‘The new doctor said.’

4.2.1.3 Hebrew

Turning to Hebrew, (Landau to appear), another 3/4 instance of agreements arises. In Hebrew, the noun *be'alim* ‘owner(s)’ shows another mismatch between its morphology and its semantic interpretation. The noun is morphologically plural, showing the *-im* suffix which marks masculine plural nouns. However, semantically it can either mean refer to a singular owner or a plurality of owners.

- (317) a. hem/hen hayu ha-be'al-im šel ha-dira
 they.MASC/they.FEM were.3.PL the-owner-MASC.PL of the-apartment
 ‘They were the owners of the apartment.’
 b. hu/hi haya/hayta ha-be'al-im šel ha-dira
 he/she was.3.SG.MASC/was.3.SG.FEM the-owner-MASC.PL of the-apartment
 ‘He/she was the owner of the apartment.’

In cases where the noun refers to a single owner, there is then a mismatch on the number information of the noun:

- (318)
- $$\begin{array}{c}
 \phi_{number} \\
 \diagdown \quad \diagup \\
 [uF:plural] \quad [iF:singular]
 \end{array}$$

Similar to the English and Russian data above, when *be'alim* controls agreement on two separate targets, we again see that the full array of agreements in (312) fails to arise, with only three out of four possible. In this paradigm in (319), we see that the verb and adjective can match according to the *uF* (319a), or match according to the *iF* (319b). With regard to mismatches, if the adjective agrees according to the *uF* and the verb the *iF*, then the mismatch is fine (319c), but the converse is not allowed (319d):

- (319) a. ha-beal-im ha-kodem maxar et ha-makom lifney šana
 the-owner-PL the-previous.SG sold.3.SG ACC the-place before year
 ‘The previous owner sold the place a year ago.’
 b. ha-beal-im ha-kodm-im maxru et ha-makom lifney šana
 the-owner-PL the-previous-PL sold.3.PL ACC the-place before year
 ‘The previous owners sold the place a year ago.’

- c. ? ha-beal-im ha-kodm-im maxar et ha-makom lifney šana
 the-owner-PL the-previous-PL sold.3.SG ACC the-place before year
 ‘The previous owner sold the place a year ago.’
- d. *ha-beal-im ha-kodem maxru et ha-makom lifney šana
 the-owner-PL the-previous.SG sold.3.PL ACC the-place before year
 INTENDED: ‘The previous owner(s) sold the place a year ago.’

4.2.2 Non-hierarchy based 3/4

With hybrid controllers, we see another type of 3/4 pattern. This type does not fit the earlier type, since it does not concern elements that occupy different positions on the agreement hierarchy, but rather they occupy the same position.

4.2.2.1 Hebrew

There is another pattern of agreement for *be'alim* which is of relevance here. If there are two adjectives which agree with *be'alim*, they are allowed to mismatch, however only if the adjective that is further from the CNP targets the *uF* value and the inner one targets the *iF* value (379a).

- (320) a. ha-bealim ha-pratijim ha-axaron šel ha-tmuna haya ha-psixoanalitikai
 ?the-owner the-private.PL the-last.SG of the-painting was.3SG the-psychoanalyst
 Jacques Lacan
 Jacques Lacan
 ‘The last private owner of the painting was the psychoanalyst Jacques Lacan.
- b. *ha-bealim ha-prati ha-axron-im šel ha-tmuna haya/ hayu
 the-owner the-private.SG the-last-PL of the-painting was.3.SG/ was.PL
 ha-psixoanalitikai Jacques Lacan.
 the-psychoanalyst Jacques Lacan
 INTENDED: ‘The last private owner of the painting was the psychoanalyst Jacques Lacan.

Note that we cannot appeal to an explanation based on the Agreement Hierarchy for this, since the relevant elements that show mismatches are both attributive elements. Furthermore, it does not suffice to make a further sub-hierarchy of attributive elements, since both of them are adjectives, and would fall into the same space.

4.2.2.2 Chichewa

Finally, I turn to Chichewa, as discussed in Corbett (1991). In the following examples, the hybrid noun is *ngwazi* ‘hero’, which Corbett claims to be of gender class 9 in the language. However, it can also trigger agreement of gender class 1, which is the default class of animates in the language. Put into current terms, we can analyze class 9 as the value of the *uF*, with class 1 being the *iF* value:

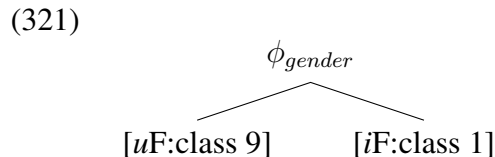

When two elements agree with *ngwazi*, we see a familiar pattern. Where the two targets match in value, the sentence is grammatical (322a) and (322b). With regard to mismatches only one configuration is possible. If the adjective targets the *iF* and the possessive pronoun targets the *uF*, then they are fine to mismatch (322c), but not conversely (322d):

- (322)
- a. *ngwazi y-athu y-oyamba*
 hero 9-our 9-first
 ‘Our first hero.’
 - b. *ngwazi w-athu w-oyamba*
 hero 1-our 1-first
 ‘Our first hero.’
 - c. *ngwazi y-athu w-oyamba*
 hero 9-our 1-first
 ‘Our first hero.’
 - d. **ngwazi w-athu y-oyamba*
 hero 1-our 9-first
 INTENDED: ‘Our first hero.’

Again, using Corbett’s hierarchy, we cannot explain these facts since they are both attributive elements. In this case, one could potentially make a further decomposition of attributive elements, and place possessives above ordinals, however, such an explanation aside from being fairly un insightful, leaves Hebrew without an explanation.

4.2.2.3 Aside: Russian profession nouns

With Hebrew and Chichewa in mind, it is worthwhile to turn our attention briefly back to Russian, which we have seen does allow for adjectives to show semantic agreement. It makes sense to question whether we can see mismatches between Russian adjectives. The answer is in general that mismatches are not allowed in Russian between two adjectives. That is, when there are two adjectives agreeing with a hybrid controller, they must match each other, and it cannot be the case that one adjective shows semantic agreement, and the other morphological, irrespective of whether it is the higher or lower one. This is shown with *genikolog* ‘gynecologist’ which is grammatically masculine but can refer to females.

- (323) a. *horošay-a obrazovannay-a ginekolog*
 good-FEM educated-FEM gynecologist.MASC
 ‘Good educated gynecologist.’
 b. **horošij obrazovannay-a ginekolog*
 good.MASC educated-FEM gynecologist
 c. **horošay-a obrazovannyj ginekolog*
 good-FEM educated.MASC gynecologist

However, there is one instance of mismatches being allowed, namely with *zubnoj vrač* ‘dentist’:

- (324) *horošaya zubnoj vrač*
 good.FEM tooth.MASC doctor.MASC
 ‘Good dentist.’

Here, we see that the form for ‘dentist’ is composed of the noun ‘doctor’ + the adjective ‘tooth’. When the referent of the NP is a female, it can be the case that an adjective shows feminine agreement, though the lower adjective ‘tooth’ remains in masculine agreement. This appears to be a lexical exception. Both of my consultants for Russian stated that this is the only possibility for mismatches.

4.3 Multiple grammars, multiple dialects

As stated, the Agreement Hierarchy is primarily a typological generalization that describes how likely certain elements in a language are to show either semantic or morphological agreement. Pronouns are more likely to agree semantically than verbs, which are in turn more likely to agree semantically than (attributive) adjectives. In the terminology of this

dissertation, this means that pronouns are more likely than verbs to show *iF* agreement, and verbs more likely than adjectives to show *iF* agreement. One way in which we can capture the effects of the hierarchy is to assume that each speaker is endowed with multiple competing grammars, as has been proposed in Wechsler & Zlatic (2003) and Bobaljik (2004). These grammars differ in which elements are open to *iF* agreement and which elements are not. Taking a hierarchy with the four categories of adjective, verb, relative pronoun and pronoun, ordered in that way, we can derive some effects of the agreement hierarchy.

This explanation relies on there being implicational relationships within the grammars, such that the presence of *iF* agreement on one of the elements in the hierarchy can serve as an indicator of whether *iF* agreement is possible on others. For instance, if in a particular grammar, a verb is a target for *iF* agreement, then so are relative pronouns and pronouns. For another grammar, if a relative pronoun is an *iF* target, then it will entail that a pronoun also is, but not necessarily a verb.

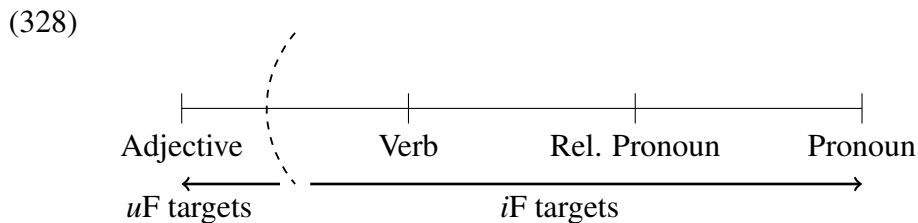
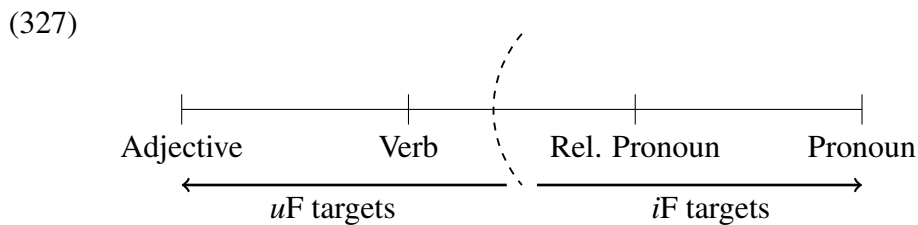
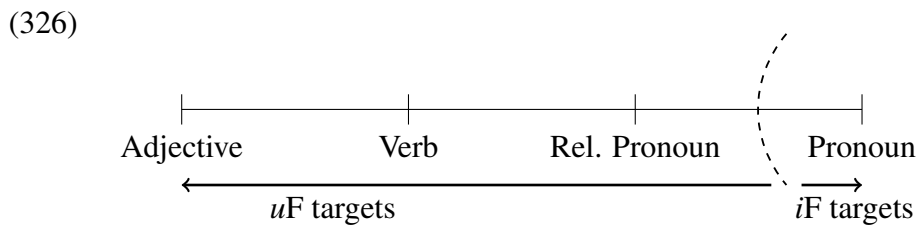
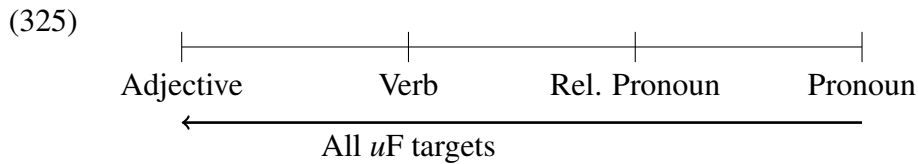

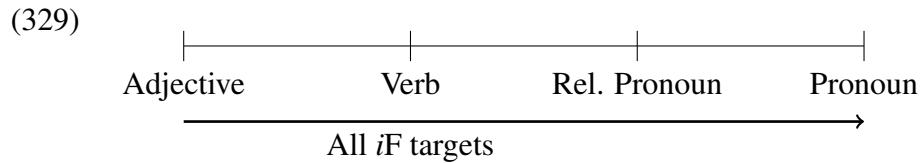

The fact that these grammars encode implicational relationships ensures that there are more grammars where pronouns can show *iF* agreement than there are where verbs can show *iF* agreement. Every grammar where verbs can show *iF* agreement will also be a grammar where pronouns can show *iF* agreement. However, the converse is not true, since there are grammars where pronouns show *iF* agreement but verbs do not, e.g. (326) and (327). This has the effect that pronominals will always show a higher frequency of *iF* agreement across a corpus than verbs.

The choice between semantic and morphological agreement is known to interact with various considerations. As shown in the corpus data from Levin (2001) discussed above, morphological agreement is more likely to be used in formal registers (in the newspapers of Levin's study), whereas semantic agreement is more likely to be used in informal registers (spoken, for instance). Thus, we can say that in formal register situations, the grammars where the *iF/uF* cut-off point is further to the left on the hierarchy are accessed more than those where the cut-off point is more to the right. For instance, the grammar of (326) is accessed more often than the grammar of (328). Importantly, even though the frequencies of *iF* versus *uF* agreement will change accordingly, the relative frequency between, say, pronouns and verbs, will remain the same.

Though this explanation captures corpus frequencies, in order to explain why 3/4 patterns exist, the implicational relationships in the grammars are crucial, in order to stop a grammar where verbs are *iF* targets and pronouns *uF* targets. This however is simply restating the Agreement Hierarchy as grammatical knowledge, and as such is un insightful as to why the Agreement Hierarchy is the way it is, and why 3/4 patterns exist in the way that they do. Wechsler & Zlatić (2003) propose one method in which we can understand the implicational relationships between elements. Pronouns are generally INDEX targets. They argue that verbal morphology diachronically stems from incorporating pronouns into the verb. As such, verbal morphology can also show a propensity to being an INDEX target. Thus, looking diachronically, one can say that verbal markers are less likely to be INDEX targets as they gradually lose their INDEX target over time. However, there are also cases where adjectives agree semantically. Whether or not one can explain the fact that adjectives show INDEX agreement in the diachronic terms through pronoun incorporation, there still remains the issue why no language exists where adjectives are INDEX targets and verbs CONCORD targets. The only way to do this, as best as I can tell is to again build the Agreement Hierarchy in at the level of grammatical knowledge, such that learners cannot

posit that adjectives search for INDEX features and verbs CONCORD.

Furthermore, the multiple grammars approach is quiet on the issue of languages where 3/4 mismatch patterns exist over different elements that occupy the same category, such as Hebrew. There is nothing obvious as to why a higher adjective should show semantic agreement and the lower one morphological agreement, but not vice versa as in Hebrew, nor the converse as in Chichewa. These instances are more reminiscent of a structural condition on mismatches that will be argued for below.¹⁰

A final criticism of the multiple grammars approach is why speakers cannot shift grammars, as is possible in code-switching.¹¹ Switching grammars from one where no targets take INDEX agreement to one where all do can give the effect that pronouns show CONCORD agreement, and adjectives take INDEX agreement. One can switch between grammars, as shown in the sentence below, where the CNP in the higher clause controls morphological agreement, and the CNP in the lower one controls semantic agreement. The sentence is grammatical, and shows that the speaker can switch between a grammar where verbs are allowed to show *iF* agreement and one where they're not:

- (330) The internal affairs committee has claimed that the staff have made too many mistakes this year.

In sum, the multiple grammars approach can explain relative frequencies of semantic agreement for elements on the Agreement Hierarchy, and certain cases of mismatches, but it suffers a number of drawbacks.

4.4 Smith (2013): Valuation Economy

Though the multiple grammars approach suffers the problems listed above, one strength that it has is that anaphor agreement controls what can be shown on verbal agreement. That is, if an anaphor shows morphological agreement, then a verb cannot show semantic agreement. The reason is that in the multiple grammars approach, there does not exist a grammar where pronouns are able to agree with the *uF* of a controller, whilst verbs agree with the *iF*.

If we limit our attention for the time being to the anaphor-verb sentences of British English, there is another way of looking at the issue. The data are repeated below in (331):

- (331) a. The government has offered itself up for criticism (with this policy).

¹⁰Landau (to appear) offers an analysis of this in Wechsler & Zlatić's terms, see the discussion in section 4.5.7.1 below.

¹¹My thanks to Susi Wurmbrand for pointing out this to me.

- b. The government have offered themselves/each other up for criticism.
- c. The government has offered [?]themselves/each other up for criticism.
- d. *The government have offered itself up for criticism.

In Smith (2013), I provided an explanation of the 3/4 pattern by proposing a condition of *Valuation Economy*, which stated that if two targets of agreement agreed with a single controller *within the same domain*, then they both had to receive a value from the same feature, either the *uF* or the *iF*:

(332) *Valuation Economy*

When an element enters more than one agreement relation, the same feature on the controller must be used for all targets that agree in the same domain.

Furthermore, I assumed that anaphors must agree syntactically, but that verbs were free to agree either in the syntax or post-syntactically. The asymmetry between these two targets of agreement was semantic in nature: anaphors need to undergo agreement in the syntax because the connection between anaphor and antecedent is more than a morphological dependency, but the two must also be linked for the semantics. Thus, in order for the anaphor to receive a complete phi-valuation before being sent to the LF-component, the feature valuation needs to happen in the syntax. As T-agreement with the subject does not have any semantic import, this valuation is free to happen post-syntactically without any influence for the semantics.

Putting these two things together, then it becomes so that the illegitimate configuration in (331d) is unable to be generated. When there is matching agreements, both targets have targeted the same feature. In (331b), where the targets match in *iF* agreement, we can assume that the *iF* feature on the CNP is active, and both the anaphor and T syntactically target it for valuation, resulting in matching plural agreement. In (331a), the anaphor targets the *uF* feature in the syntax, and T agrees with the *uF* of the CNP either syntactically (obeying *Valuation Economy*) or post-syntactically.

The interesting cases were the ones with mismatches. In the allowed mismatch (331c), the anaphor targets the *iF* value of the CNP, becoming plural, but T values post-syntactically and receives the value of singular. Crucially at this point, there is no violation of *Valuation Economy*, since the different agreements happen in different components. The anaphor agrees syntactically, but T agrees post-syntactically, which is allowed since *Valuation Economy* is only applicable to agreements that happen in the same component. The illegitimate mismatch case in (331d) turns out to be unable to be generated. The reason being is that anaphors must always agree within the syntax. Therefore, the *uF* agreement must come from the syntax. However, the plural value on T shows that it has agreed with the *iF* feature of the CNP. Given that *iFs* are visible only to syntactic agreement, and not

at PF, then it must be the case that T would have undergone syntactic agreement as well. Yet, an anaphor agreeing with the *uF* and T agreeing with the *iF* *both within the syntax* violates *Valuation Economy*. Hence, the sentence is not able to be generated.

The *Valuation Economy* approach works well for the British English paradigm, since anaphors in part limit what agreement a verb can show. Since anaphors must agree in the syntax, then if a verb agrees within the syntax, it must match the anaphor. If the verb does not agree in the syntax, then it must take the *uF* value. The problem that is faced by the *Valuation Economy* approach comes from looking outside of verb-anaphor mismatches. Take Russian for example:

- (333) a. Novyj vrač skazal.
 new.MASC doctor said.MASC
 ‘The new doctor said.’
- b. Novaja vrač skazala.
 new.FEM doctor said.FEM
 ‘The new doctor said.’
- c. Novyj vrač skazala.
 new.MASC doctor said.FEM
 ‘The new doctor said.’
- d. * Novaja vrač skazal.
 new.FEM doctor said.MASC
 ‘The new doctor said.’

Valuation Economy struggles to explain this pattern in a truly principled manner. In British English, the anaphor restricted the verb. However, to generalize the account to Russian, we need the verb to restrict the adjective. However, there doesn’t seem to be a good reason for why the verb in Russian must agree in the syntax, given that in British English, verbs can happily wait until PF in order to undergo agreement.

4.5 The origins of *Valuation Economy*

There is potentially another way of looking at things. For this subsection, I will keep the discussion informal, before providing a more complete exposition below starting in section 4.5.1 below. Elements on the right of the Agreement Hierarchy seem to control what can be shown on elements to the left. *Valuation Economy* can be derived of sorts if we assume some aspect of timing in agreement, such that elements on the right of the hierarchy undergo agreement before elements to the left on the hierarchy. If we couple this ordering with some condition whereby agreement can shift from looking at the *iF* to

the *uF*, but crucially not vice versa, then we gain the effects of the hierarchy. Consider the following set of assumptions:

- (334) a. The order of agreements is: anaphor \prec verb, where \prec implies precedence
 b. If agreement targets both *iF*s and *uF*s on a controller, the *iF* must be agreed with first.
- (335) a. The government has offered itself up for criticism (with this policy).
 b. The government have offered themselves/each other up for criticism.
 c. The government has offered ? themselves/each other up for criticism.
 d. *The government have offered itself up for criticism.

These two assumptions will capture the 3/4 pattern of British English in much the same way that *Valuation Economy* did. The cases where there are matching agreements on anaphor and verb are simple to handle; both the anaphor and verb choose the same feature, and not much needs to be said. The interesting case is the contrast between (335c) and (335d). In the derivation, *per* (334a), anaphors undergo agreement before the verb. Since we are dealing with a mismatch, it is the case that both *iF* and *uF* of the controller are being used for agreement. (334b) states that in this case, it is the *iF* that must be agreed with first. Thus, the anaphor, since it agrees first, will show *iF* agreement and the verb will show *uF* agreement. The converse mismatch, that of (335d) is not generable, since it would require either that the anaphor agrees with the *uF* first and the verb then with the *iF* second. This is ruled out by (334b). A derivation that is in compliance with (334b) would see the verb agree first with the *iF* and then the anaphor agree with the *uF* after. However, this derivation is ruled out by (334a). Thus, only one mismatch is able to be generated.

If we supplement the set of mock assumptions above in (334) with a further one relating adjectival agreement and verb agreement, we can capture the Russian mismatches where the adjective and verb can mismatch as long as the verb shows *iF* agreement and the adjective shows *uF* agreement.

- (336) a. The order of agreements is: anaphor \prec verb \prec adjective, where \prec implies precedence
 b. If agreement targets both *iF*s and *uF*s on a controller, the *iF* must be agreed with first.

Again, the combination of (336a) and (336b) combine to create the attested mismatch and rule out the unattested mismatch, as I invite the reader to check.

The problem with such statements as in (336) is the question of *why* language is this way, but also why does language apparently operate in *only* this manner? If such statements like (336a) exist in a grammar of a language, what is to stop the following, which

would give a language with the opposite effect of the hierarchy, where mismatches where an adjective shows *iF* agreement, but the verb *uF* agreement would be possible. However, such languages are apparently unattested:

- (337) a. The order of agreements is: adjective \prec verb \prec anaphor, where \prec implies precedence
 b. If agreement targets both *iF*s and *uF*s on a controller, the *iF* must be agreed with first.

We could stipulate that the assumptions in (336), and only those assumptions are part of Universal Grammar, which would rule out grammars like (337) from ever being posited by learners, yet this is un insightful. Better is to try to derive (337) from general properties. I propose that this can be done. The explanation comes in two parts. We need to understand the timing effect in (336a), and the shifting condition of (336b). I discuss the timing issue first, before moving onto the shifting condition.

4.5.1 Why anaphor \prec verb \prec adjective?

The issue of timing, I propose, comes from the order in which agreement targets combine into the structure with agreement controllers. The idea in brief is that agreement relations are established as soon as controller and target are in the derivation, and that the stage in which anaphors and their antecedent are first together in the derivation is before the stage that T and the agreement controller are. What is crucial to get the timing effects is that agreement relations are established as soon as possible. Recall from chapter 3 that following Arregi & Nevins (2012) and Bhatt & Walkow (2013) I split the AGREE operation of Chomsky (2000, 2001) into two processes, AGREE-LINK and AGREE-COPY.

- (338) Agreement by Probe Γ with Goal γ proceeds in two steps:
- a. AGREE-LINK: a Γ has unvalued ϕ -features that trigger Agree with γ (possibly more than one). The result is a link between Γ and γ .
 - b. AGREE-COPY: the values of the ϕ -features of γ are copied onto Γ linked to it by AGREE-LINK.
 - i. if AGREE-COPY happens at transfer, this requires that γ c-command the Γ .

The crucial point of this process that is relevant for this chapter is the point at which AGREE-LINK takes place. I propose here that AGREE-LINK happens as soon as possible in the derivation: as soon as Γ and γ can establish an AGREE-LINK relation, they

must do so. In practice, this means the first derivational step at which Γ and γ stand in a configuration where they can be linked.¹²

(339) Establish AGREE-LINK between a probe and a goal as soon as possible.

For the time being, I restrict attention to verbal agreement and anaphor agreement. Consider the sentence in (340), which has the numeration in (341):

(340) John hit himself.

(341) {John, T, v, V, himself}

Taking the standard assumption that structure is built from bottom-to-top (but see, e.g. Phillips (2003) for a top-down approach), the derivation proceeds as follows:

(342) a. Merge V and *himself*

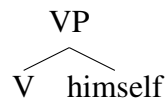

b. Merge v

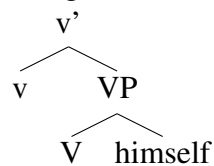

c. Merge *John*

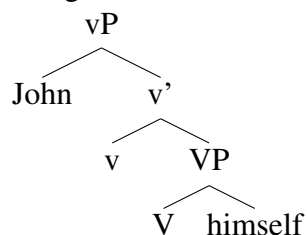

¹²Recall from the discussion in chapter 3 that the usual assumptions regarding c-command hold, such that Γ and γ must be in a c-command relation in order for AGREE-LINK to be possible, but I remain agnostic as to whether any c-command relation is possible, or that whether a Reverse Agree configuration must always hold (Wurmbrand 2011, 2012a,b, Zeijlstra 2012).

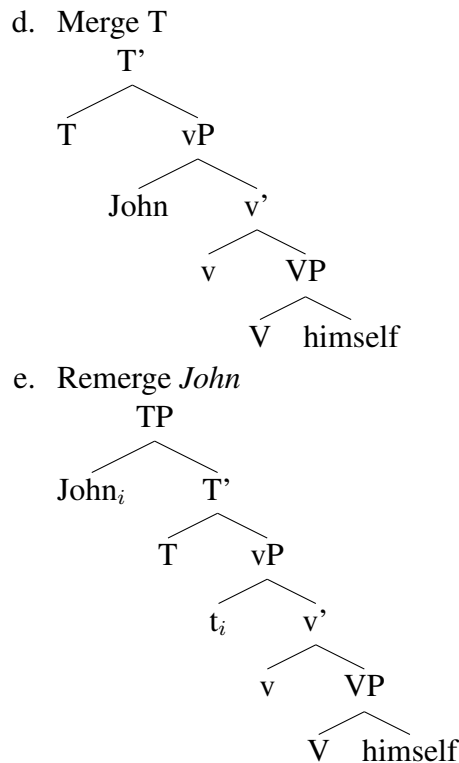

The important stages in the derivation are (342c) and (342d). The stage in (342c) is the first stage in the derivation where *John* and the anaphor appear in the derivation together. (342d) is the first stage where T and *John* are in the derivation together. Thus, if AGREE-LINK is formed as soon as possible between targets and controllers, it follows that anaphors will undergo AGREE-LINK with the controller before T does, deriving the first part of the timing issue.¹³

The second part of the timing issue relates to adjectives, and specifically, why they undergo agreement after verbs and anaphors. The answer to this question comes from the proposal in Stepanov (2001) that adjuncts must merge late into the structure. Since attributive adjectives are adjuncts, this means they merge counter-cyclically into the derivation, crucially after both anaphors and T.¹⁴ Thus, the first point in the derivation where an adjective can undergo AGREE-LINK with its controller, occurs after both T and anaphors

¹³Note that AGREE-LINK does not copy the features of the goal onto the probe, but only establishes the relation between the two.

¹⁴There is controversy over whether adjectives are adjuncts or not. Cinque (2010) argues that adjectives each head their own projection, which would make them unlikely candidates for being adjuncts, however, Bošković (2013) argues that in many languages adjectives are adjuncts. There is potentially certainly scope for both approaches to be correct, and that languages differ parametrically on this point (see also the discussion of Chichewa possessive pronouns below), but here I take the strong view that all adjectives are

will have established AGREE-LINK relations with the controller. To illustrate, consider the sentence in (343), which has the numeration in (344). The derivation proceeds as in (345):¹⁵

(343) Hungry owls feed themselves.

(344) {hungry, owls, T, v, V, themselves}

(345) a. Merge V and *themselves*

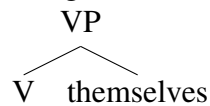

b. Merge v

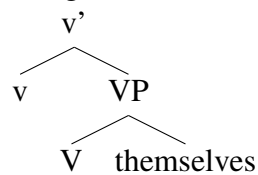

c. Merge *owls*

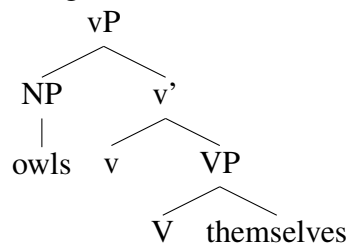

d. Merge T

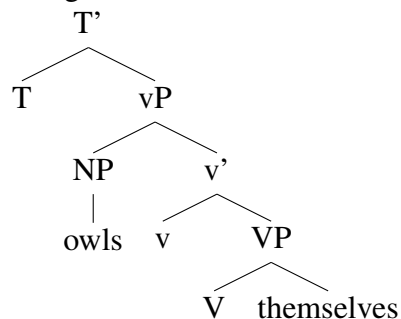

adjuncts.

¹⁵In the derivation, irrelevant structural details and steps are ignored for reasons of space.

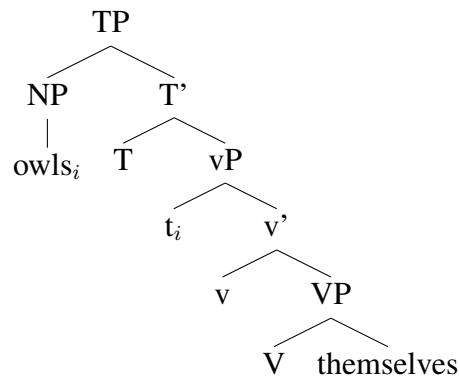
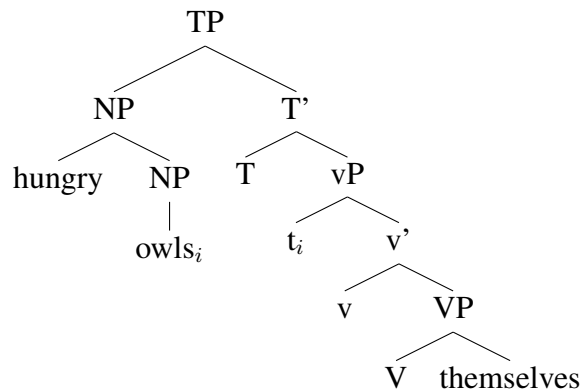
e. Rmerge *owls*f. Merge *hungry*

If the adjective were to undergo agreement with the head noun, it would only be able to do so at the point of the derivation in (345f). Thus, with the condition that AGREE-LINK is established as soon as possible, coupled with a bottom-up derivation and late merger of adjuncts, we are able to derive the timing effect, such that anaphors agree before verbs, and verbs in turn before adjectives. Recall also from section 3.5 that adjectives undergo DP-internal agreement with the features that are on their sister node - the NP which they adjoin to. Thus, *hungry* in (345f) undergoes agreement with the lowest segment of NP.

4.5.2 The shifting condition

Now that we have the timing effect sorted, the shifting condition remains to be explained. The shifting condition refers to the following statement that we saw before, repeated from above:

- (346) If agreement targets both *i*Fs and *u*Fs on a controller, the *i*F must be agreed with first.

The shifting condition describes the state of affairs whereby if there are two targets for agreement, both agreeing with the same controller, and one agrees with the *iF* and one with the *uF*, it must be the element that agrees first that agrees with the *iF*. Put another way, once an element agrees with the *uF* of a controller, it is not possible for further agreements to target the *iF*.

Recall from section 4.1.2 that *iFs* are not open for agreement by default; only certain classes of hybrid nouns in languages allow their *iFs* to be visible for agreement. However, *iFs* do not always need to be agreed with. I have proposed that in order for an *iF* to be agreed with, it must be *active*. Activation as we have seen is limited to AGREE-LINK, but with the proviso that if the *iF* is linked to via AGREE-LINK, then the value of the feature must be copied to the target. Further, I assume that *iFs* are not able to become active in the derivation; they must either enter the derivation as active, or remain inactive throughout the derivation. However, *iFs* are able to be deactivated if they enter into an AGREE-LINK relation. This deactivation is crucially optional: it does not have to happen, but it may.¹⁶ Furthermore, I assume that *iF* agreement must happen if the feature is active, effectively, the possibility of *iF* agreement bleeds *uF* agreement. The three important assumptions are given below:

- (347) An *iF* can enter the derivation either as active or inactive.
- (348) AGREE-LINK can deactivate an *iF*, rendering it invisible to further AGREE-LINK operations. Inactive features cannot be activated.¹⁷
- (349) An *iF* that is active cannot be ignored for agreement.

¹⁶The reader might be wondering - and they'd be right to - whether the same holds for *uFs*. I think not. If the proposal that *iFs* can be deactivated is true, and it would also apply to *uFs*, this would potentially leave a target for agreement without any feature to agree with. It does seem *ad hoc* to say that whilst *uFs* are always active, *iFs* can be either active or inactive, and that they can shift from being active to inactive, as there doesn't seem to be a good reason why they would differ in this way. However, it could be reflective of the somewhat special status that *iFs* have in agreement - the default seems to be that languages agree with *uFs*, and that something special needs to happen in order to agree with an *iF*. Further research is required on this issue, which I must unfortunately leave for the future, however one way of looking at the issue is that agreement is always a process that happens between an probe and a *uF*, which don't have an active/inactive distinction, but just are active. This process is superseded by agreement with an *iF* if possible. *iF* agreement then is a strange type of blocking effect. For now, I leave open whether there is anything deeper to the shifting condition, and for now simply stipulate that only *iFs* can become inactive in the derivation.

¹⁷The reader might also be wondering - and again, they'd be right to - why a change in activity only goes one way; why can an active *iF* become inactive, but not vice versa? The reason is that it takes an AGREE-LINK relation to deactivate the feature. However, there is no operation that can be specified to look for an inactive feature which would activate it in the process. By definition, inactive features are invisible to such things.

These assumptions derive the shifting condition. Agreement from a single controller can shift from *iF* to a *uF* by the *iF* becoming inactive. The inactivation of the *iF* renders it invisible to further AGREE-LINK relations, and as such only *uF* agreement is possible from then on. However, agreement cannot shift from *uF* to *iF* since this would require that the first element that establishes AGREE-LINK with the controller would ignore an active *iF*. However, by (349), this is disallowed. Furthermore, since *iFs* can only be deactivated throughout the derivation, but not activated, then there is no possibility for the first target of agreement to establish AGREE-LINK with a *uF*, then the *iF* be activated, and then the second target establish an AGREE-LINK relation with the now-active *iF*. Such a possibility is ruled out by (348).

4.5.3 Interim summary

In the above two subsections I have provided a manner in which to derive the effects of the informal assumptions that are repeated below from above, which as discussed earlier derive the effects of Valuation Economy in a manner that generalizes beyond British English.

- (350) a. The order of agreements is: anaphor \prec verb \prec adjective, where \prec implies precedence
 b. If agreement targets both *iFs* and *uFs* on a controller, the *iF* must be agreed with first.

(350a) derives from the way that structure is built, and crucially from the fact that anaphors will undergo AGREE-LINK with the controller before the verb does. Since adjectives are adjuncts, and merge late into the structure (Stepanov 2001), they follow both. (350b) follows from the fact that *iFs* can optionally enter the derivation as active, but become inactive throughout the derivation, coupled with the assumption that *iF* agreement effectively bleeds *uF* agreement whenever it is possible. In the following subsections, I go through the 3/4 paradigms in turn, showing how these assumptions allow us to unify the hierarchy-based 3/4 patterns under the same rubric, which is a welcome result. In section 4.5.7 I show how it can be further extended to the mismatches among Hebrew adjectives, which captures structural 3/4 effects.

4.5.4 British English

- (351) a. The government has offered itself up for criticism (with this policy).
 b. The government have offered themselves/each other up for criticism.
 c. The government has offered [?]themselves/each other up for criticism.

- d. *The government have offered itself up for criticism.

As soon as the anaphor can, it enters into an Agree relationship with the subject. In the simplest case, this will be once the subject merges into Spec,vP. Once the subject merges, the anaphor undergoes AGREE-LINK with it, and establishes the connection.¹⁸ If the *iF* on the controller does not enter the derivation If the *iF* on the controller is active, then semantic agreement is possible. If the *iF* is not active, then only *uF* agreement is possible and we see morphological agreement throughout. If the *iF* is active, and does not become deactivated in the derivation, then we see semantic agreement throughout.

Let's consider a derivation in full, taking the following sentence as an example:

- (352) The committee *is/are* commending themselves/*itself*.

- (353) *Firstly, the anaphor merges with V:*

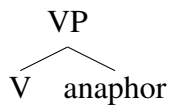

- (354) *Merge of v*

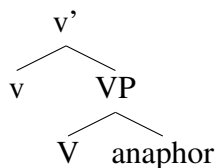

- (355) *Merge of CNP subject into Spec,vP.*

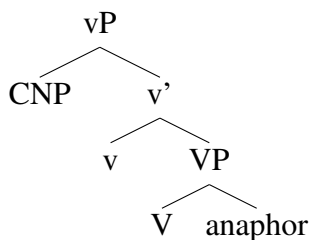

¹⁸Note that AGREE-COPY happens later to take the value of the feature, which requires a Reverse Agree relation.

This is the first stage of the derivation in which the CNP and the anaphor are in the same structure. Following the assumption that AGREE-LINK relations are established as soon as they are able to, at this point, the anaphor is able to probe the CNP, so AGREE-LINK is established between the anaphor and its antecedent, the CNP. Note that this does not value the anaphor, which following the earlier proposal happens with AGREE-COPY. Now the question of the activity of *iF* becomes important. If the *iF* on the controller (the CNP) has entered the derivation as active, then AGREE-LINK is established between the anaphor and the *iF* on the controller, which with CNPs will result in plural agreement on the anaphor. If it is inactive, then the only possible target is the *uF* of the controller, and singular agreement will be the result. Were the *iF* active, then it can become deactivated when the anaphor established AGREE-LINK with the *iF*. If so, then no further AGREE-LINK will be able to be established with the *iF*.

Moving on to the next stage of the derivation, T merges into the structure:

(356) *T merges into the structure*

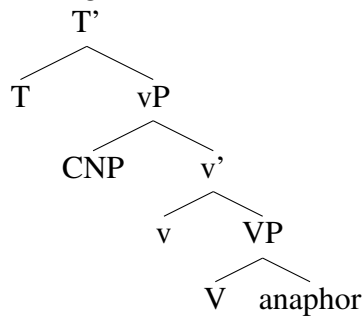

Finally, the CNP remerges in Spec,TP. T then probes the CNP.

(357) *Remerge of CNP into Spec,TP*

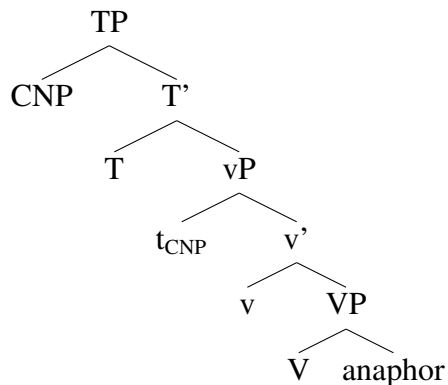

With agreement between T and the CNP, the status of the *iF* is again important. If the feature is active, then T must agree with the *iF* on the CNP, and yield plural agreement. Since the *iF* is active here, then this entails that the anaphor must also show plural agreement. By assumption, *iFs* cannot become active throughout the derivation. Thus, if it has reached T being active, then the anaphor must have agreed with the *iF*. More complicated is a derivation where the feature is inactive at the point of T undergoes AGREE-LINK with the CNP. Since the feature is inactive, then T can only agree with the *uF* and show singular agreement. However, this tells us nothing about the anaphor. The anaphor can be singular if the *iF* entered the derivation as inactive. In this instance, we have matching singular agreement on the anaphor and T. If however, at the stage that the anaphor underwent AGREE-LINK with the CNP the *iF* on the CNP was active, but became deactivated through this process, then we have a situation where the anaphor has plural agreement, but T must be singular. This derivation, whereby the anaphor deactivates the *iF* results in the licit mismatch.

Furthermore, the illicit mismatch, where T has plural agreement and the anaphor singular is unable to be generated. The reason is similar in spirit to the *Valuation Economy* approach given in Smith (2013) and summarized above; singular agreement on the anaphor entails that only singular agreement is possible on T. With the anaphor showing singular agreement, it must then be the case that the *iF* on the CNP has entered the derivation as inactive, and so *no* plural agreement is possible. The option does not exist for the *iF* to be inactive at the point that the anaphor and CNP undergo agreement, but active at the point of T agreement.

Note that this explanation holds even when the anaphor is buried in a DP away from the verb. Consider the following:

- (358) a. The committee that gave themselves a hefty payrise is being indicted on charges of corruption.
 b. *The committee that gave itself a hefty payrise are being indicted on charges of corruption.

The first mismatch is ok, because the anaphor again undergoes AGREE-LINK before the verb, since the CNP merges into a structure containing the anaphor (the complex DP) before the verb does. Thus, there is the possibility to deactivate the *iF* before the verb has a chance to.

4.5.5 Russian

This subsection is split into two parts. Section 4.5.5.1 discusses the 3/4 pattern of agreement. Section 4.5.5.2 returns to an outstanding issue from chapter 3.

4.5.5.1 The 3/4 Pattern of Russian

As to the 3/4 pattern in Russian, it follows the same process. Recall that I follow Stepanov (2000, 2001), I assume that adjuncts merge late into the structure.¹⁹ This means that verbs will undergo agreement before adjectives do.

- (359) a. Novyj vrač skazal.
 new.MASC doctor said.MASC
 ‘The new doctor said.’
 b. Novaja vrač skazala.
 new.FEM doctor said.FEM
 ‘The new doctor said.’
 c. Novyj vrač skazala.
 new.MASC doctor said.FEM
 ‘The new doctor said.’
 d. *Novaja vrač skazal.
 new.FEM doctor said.MASC
 ‘The new doctor said.’

It’s best to once more spell out the derivation of how the structure is built.

- (360) *Merge of v with V*



- (361) *Merge of vrač into Spec,vP*

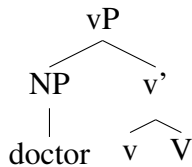

- (362) *Merge of T*

¹⁹Stepanov takes the strong position that adjuncts *must* merge late into the structure, but there are proposals where they may, but not must, merge late (Lebeaux 1988).

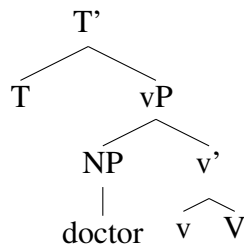
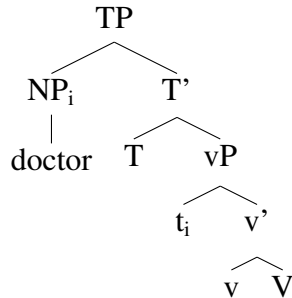
(363) *Remerge of vrač into Spec,TP*(364) *Late merger of adjunct*

At point (363) in the derivation, T undergoes agreement with the subject NP. If the *iF* is inactive, then T will only be able to agree with the *uF*. If the *iF* on the controller is active, then T must undergo AGREE-LINK with the *iF* feature which will result in feminine agreement. If the *iF* is inactive, then T will only be able to agree with the *uF*. If T does establish an AGREE-LINK relation with the *iF* on the controller, there are two options. Firstly, the *iF* remains active, and will be available for agreement with the adjective when it undergoes late merge in (364). If however agreement of T deactivates the *iF* when it agrees with it, then only the *uF* will be visible to the adjective.

Again, with regard to the instances of mismatches, we see that when the *iF* on the controller enters the derivation active, but becomes inactive through agreement, we gain the licit mismatch. However, yet again, the illicit mismatch is unable to be generated since the *iF* must be agreed with if it enters the derivation as active. There is no option for T to

not agree with the *iF* whilst it is active, which would give the illicit mismatch. We see the exact same effect as in British English, which is a welcome result.

4.5.5.2 Yet more Russian: On the difference between two mismatches

There is a final point of that should be noted, which requires strengthening the theory a little further. Consider the following sentence:

- (365) a. Po ulice šla novaya vrač
 along street went.f new.f doctor
 ‘Along the street went the new doctor.’
 b. *Po ulice šel novaja vrač
 along street went.m new.f doctor
 INTENDED: Along the street went the new doctor.’

The contrast between (365a) and (365b) shows that a mismatch that goes against the hierarchy is not tolerated. Whilst at first blush it is not so surprising that a mismatch that goes against the hierarchy is ungrammatical in light of the proposal here, this one is genuinely surprising. The reason is that this is a locative inversion structure, and as such the controller of agreement lies underneath T^0 at LF, according to Glushan (2013). We might expect a derivation to be possible however, whereby AGREE-LINK creates a link between T and *vrač*, does *not* deactivate the *iF* on *vrač*, which is then able to link to the adjective once it is merged into the structure. At the point of AGREE-COPY the adjective should be able to take the value from the *iF*, but since T cannot, *uF* agreement ought to be possible on T. Such a derivation would give (365b), but this is ungrammatical. Thus, it seems as though a mismatch against the Agreement Hierarchy is absolutely ruled out, and one cannot be derived if one of the elements is not in a position to undergo *iF* agreement. It is certainly possible to see (365b) as evidence against my approach, and say that the hierarchy must be a deep part of grammatical knowledge. However, if we adopt the condition on *iF* agreement given in 3 that failure to copy an *iF* value with AGREE-COPY results in a crash of the derivation, then we achieve the same effect.²⁰

- (366) If AGREE-LINK has linked a goal with an *iF*, AGREE-COPY must copy the value of the *iF* onto the goal.

(365b) is ruled out because the AGREE-LINK must have linked T to the *iF* of *vrač*, but when the value on the *iF* failed to be copied to T, the derivation crashed. The theory

²⁰It is perhaps notable that Russian is the only language which seems to motivate this condition, albeit in two cases. I leave open the question of whether (366) reflects a genuine principle of UG, or an idiosyncratic property of Russian, hoping that future evidence will bear deeper on the question.

stands intact, albeit with a slightly ugly stipulation. In chapter 3 I showed that adopting this condition allows us to analyze an apparently ‘optional’ movement in Russian as not being truly optional, but rather happens because of Last Resort. Recall that this example is apparently at odds with the following where the QNP appears to control *uF* agreement on the verb, but *iF* agreement on the adjective (from Franks 1994). However, the verbal agreement is crucially not *uF* agreement here, but default agreement, thus the verb is not ignoring an active *iF*, but rather there is no AGREE-LINK between the QNP and T.

- (367) a. Pjat’ krasivyz devušek prišli
 five beautiful-GEN.PL girls-GEN.PL arrived-PL
 ‘Five beautiful girls arrived.’
 b. Prišlo pjat’ krasivyx devušek
 arrived-N.SG five beautiful-GEN.PL girls-GEN.PL
 ‘Five beautiful girls arrived.’

4.5.6 Hebrew

Finally, we return to the Hebrew cases where verbs and adjectives mismatch. The relevant data are repeated below:

- (368) a. ha-beal-im ha-kodem maxar et ha-makom lifney šana
 the-owner-PL the-previous.SG sold.3.SG ACC the-place before year
 ‘The previous owner sold the place a year ago.’
 b. ha-beal-im ha-kodm-im maxru et ha-makom lifney šana
 the-owner-PL the-previous-PL sold.3.PL ACC the-place before year
 ‘The previous owners sold the place a year ago.’
 c. ? ha-beal-im ha-kodm-im maxar et ha-makom lifney šana
 the-owner-PL the-previous-PL sold.3.SG ACC the-place before year
 ‘The previous owner sold the place a year ago.’
 d. *ha-beal-im ha-kodem maxru et ha-makom lifney šana
 the-owner-PL the-previous.SG sold.3.PL ACC the-place before year
 INTENDED: ‘The previous owner(s) sold the place a year ago.’

As can be seen in the data, sentences where the adjective and verb match in agreement are fine, irrespective of whether it is plural or singular. Mismatches are tolerated only in one manner, whereby the adjective shows *uF* agreement and the verb *iF* agreement, as shown in (368c). There is a slight difference that should be noted is that the verb always reflects the interpretation of the noun (though as pointed out by Landau, the verb does not determine the number of the noun). When the verb is singular in (368a), it refers to a

single owner. When the verb is plural, it refers to a plurality of owners (368b). We must therefore supplement Hebrew with a condition that prefers *iF* agreement on verbs:²¹

(369) Where possible, verbs agree with the *iF* on a noun.

This means that if there is a noun that is able to have its *iF* active for agreement, it must do so when a verb agrees with it. Thus, derivations where the *iF* is active are take precedence when there is a verb. Now, when there is matching agreements, in (368a) and (368b), the *iF* has stayed active throughout the derivation, such that when the adjective undergoes late adjunction, it will agree with the *iF* and show matching agreement with the verb.

In the licit mismatch (368c), we see that when the verb undergoes AGREE-LINK with the *iF* on the noun, it deactivates the *iF* and makes it invisible for further agreement. Thus, when the adjective late-merges into the structure, it can only agree with the *uF* on the noun, resulting in a mismatch. Once more, the illicit mismatch in (368d) cannot be generated since it would involve the verb ignoring the *iF* on the noun, which is not allowed if it is active for agreement.²²

4.5.7 Hebrew double adjectives

4.5.7.1 Not a regular 3/4 pattern

The final 3/4 cases require more of an explanation. Landau (to appear) shows that a mismatch between two adjectives is allowed if it is the higher adjective that shows semantic agreement and the lower one morphological agreement.

Chichewa is different from Hebrew in that we are not dealing with two adjectives as the targets of agreement. Rather, the two targets are a possessive pronoun and an ordinal numeral. Another difference between Hebrew and Chichewa is that although they are both languages where the noun appears at the front of the N/DP, Hebrew is commonly taken to have a left branching structure whereby elements to the left are the most deeply embedded

²¹Note that we cannot go with a stronger condition that verbs always show *iF* agreement in Hebrew. Assuming that what I propose in 3 for CNPs, namely that they are *iF:pl,uF:singular*, is the right way of looking at CNPs in languages even outside of British English, this would predict that verbs would show plural agreement with CNPs, which is not borne out in Hebrew (data from Landau to appear):

- (i) ha-ka'hal hitkanes ba-lobi
 the-crowd gathered.SG in.the-lobby
 'The crowd gathered in the lobby.'

²²Doubly so in fact for Hebrew, given both the requirement that *iFs* are in general not ignored if active, but also (369) given above.

(see for instance Sichel 2002, whereas Chichewa has been argued to have a right branching structure, whereby the elements to the right are the most deeply embedded Carstens (1991, 1993).²³ The difference in structure derives from a difference in what gets moved to the left of the N/DP. In Hebrew, both Sichel (2002) and Landau (to appear) take the Hebrew noun phrase to involve roll-up phrasal movement (see also Cinque 2005) to the specifier of DP. However, Carstens (1991, 1993) argues that Bantu N-initial word order derives from N to D movement of just the noun. Thus, elements that modify the noun are left low in the structure. The difference between the two languages can be seen in the following structures:²⁴

(370) Hebrew

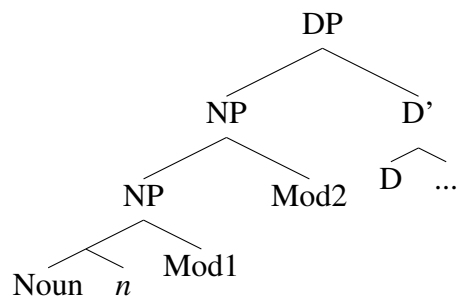

(371) Chichewa

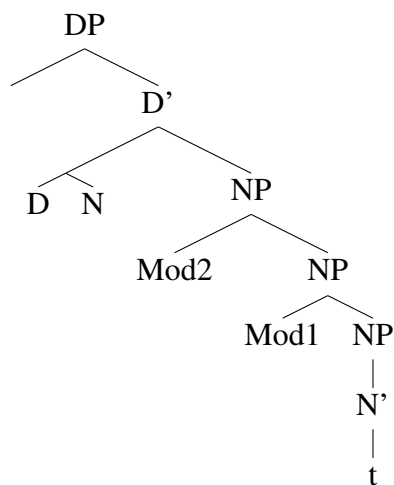

²³Landau treats Chichewa and Hebrew as having the same structure without discussion, and proposes to unify them under the same theory. However, due to the arguments given in Carstens (1991, 1993), I believe that there is sufficient reason to treat them differently. Chichewa word order is discussed in more detail below.

²⁴Mod = Modifier.

In the trees, the thing to pay attention to is the position of Mod1 and Mod2. In both structures, Mod2 c-commands Mod1, however it is linearly to the right in the Hebrew structure, and linearly to the left of Mod1 in the Chichewa structure.

For Landau, the attested mismatch in Hebrew derives from there being a split in where (what more or less corresponds to) *i*Fs and *u*Fs are introduced. *u*Fs are introduced on *n*, and *i*Fs in the dedicated number head higher up. The mismatch came about because the higher adjective merged above NumP, and the lower one below. Using downward agreement, we end up with the effect that the higher adjective showed *i*F agreement and the lower one *u*F agreement.

(372)

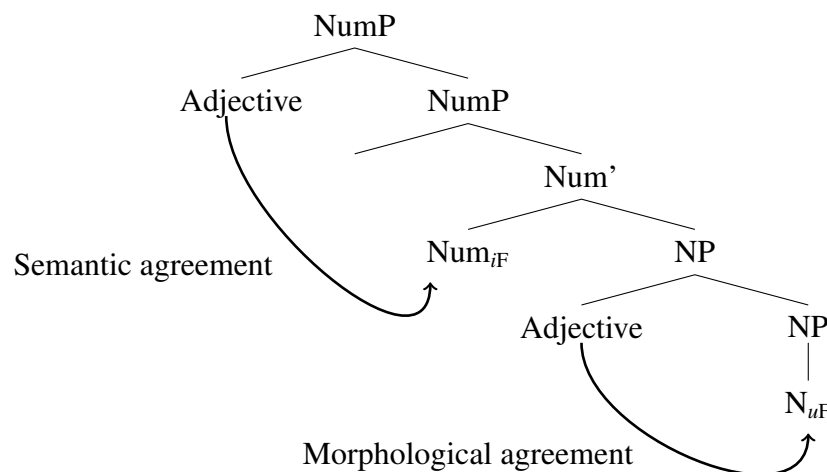

However, his assumptions there are incompatible with what was argued for in chapter 3 whereby semantically motivated agreement is only possible in an upward manner. The force of this criticism depends on how convinced the reader is by the arguments given in chapter 3 however. Such an explanation is not available to us, because of the fact that agreement that targets *i*F agreement must go upwards. If we were to follow the spirit of Landau's explanation, and allow mismatches to arise from the target merging in between where *i*Fs and *u*Fs are introduced, we make the opposite prediction. From a structural perspective, we would expect that whenever the higher element shows *i*F agreement, the lower element would also be able to show it, all else being equal. As we will see, Chichewa conforms beautifully to this, but Hebrew does not.

On the explanation pursued here, if the lower adjective merges into the structure first, we would expect that it would be the lower adjective that would always be able to show semantic agreement, with mismatches arising if the lower adjective agrees with the *i*F on

the controller, before deactivating it before the higher adjective merged into the structure. However, this predicts the wrong state of affairs for Hebrew, where it is in fact the higher adjective that shows semantic agreement when there is a mismatch.

4.5.7.2 Different timing of adjunct merger

The answer which I propose is that languages differ in the order in which they merge adjuncts. Key to the proposal above is that adjuncts merge counter-cyclically. Merge in the sense of Chomsky (1995) works in a cyclic manner because merge must always take place at the root, explained by Chomsky in terms of economy. Yet given that adjuncts merge counter-cyclically, there is no obvious requirement that they do so in a cyclic manner, that is, there seems to be no real requirement that they merge in the order of lowest adjunct to highest adjunct; it is inherently uneconomical either way. There is thus no reason to suspect that ‘cyclic’ counter-cyclic merger is forced in the case of adjunction.

Suppose that it is a parametric choice across languages as to whether when merging multiple adjuncts at the same site, the adjuncts merge in top-down or bottom-up fashion. We can formalize this with the following statement:

(373) In case of adjunction, adjoin to the {highest/lowest} segment of the adjunction site.

Now depending on which option the language takes with respect to where adjunction takes place, we see a difference in whether structurally higher or structurally lower adjectives have merged first. For languages that merge at the highest segment, the adjectives which are higher in the structure have merged after ones that are lower. For languages which merge adjuncts at the lowest segment, adjectives that are higher in the structure must have merged before the ones that are lower.

To illustrate this, take a simple noun phrase like *big red car* in English. Suppose that English merges adjectives at the *highest* segment of the adjunction site, there are two possible derivations. In the first, *red* merges before *big*:

(374) a. NP
 |
 car

b. *Merge red with highest segment*
 NP
 / \
 red NP
 |
 car

c. *Merge big with highest segment*

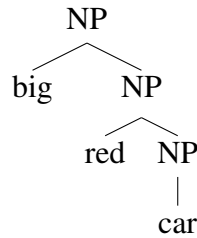

In the above, the correct order surface order is obtained.²⁵ The first adjunction trivially targets the highest segment of NP, since there is only one segment. In the second adjunction, *big* then merges to the highest segment, and the result is that it is structurally higher than *red*. This gives the observed output of English.

In the alternate derivation which involves the opposite order of merge of the adjectives, we end up with the output that is not observed, where *red* ends up merging in a higher position than *big*.

(375) a. NP



b. *Merge big with highest segment*

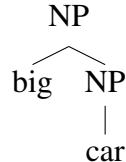

c. *Merge red with highest segment*

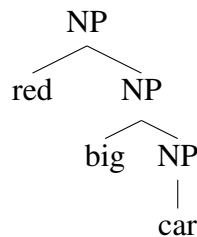

Thus, in a language where adjuncts adjoin to the highest segment of the adjunction site, adjectives that are lower in the structure must have adjoined first.

²⁵Note that I am not talking about a representational condition on which adjective orders are possible or not. All I am talking about here is the derivations involving two adjuncts, which happen in English to give the surface order *big* >> *red*.

Now consider the other type of language, where adjuncts target the lowest segment of the adjunction site. Again, I will illustrate with an English example, without committing to which option English chooses. If *red* merges into the structure first, we obtain the wrong output. First, *red* merges with NP, as above. The segment attached to is trivially the lowest one. However, when *big* comes to merge into the structure, it targets the lowest segment, and so will attach to the bottom segment of NP, in contrast to the above:

(376) a. NP



b. *Merge red with lowest segment*

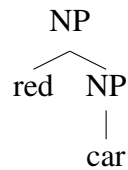

c. *Merge big with lowest segment*

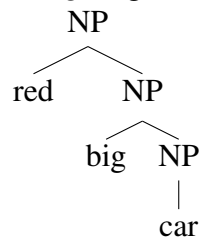

Now consider the opposite order of merging. If adjuncts in a language adjoin at the lowest segment of the adjunction site, then it must be the case that adjectives that end up being structurally higher have merged into the structure before ones that are structurally lower.

(377) a. NP



b. *Merge big with lowest segment*

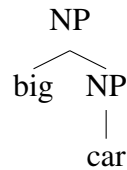

c. Merge red with lowest segment

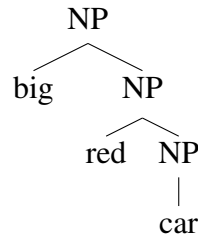

The following summarizes the result of the different options of this parameter:

- (378) a. If a language merges adjuncts at the HIGHEST segment of the adjunction site, adjectives that are structurally higher in the output have merged *after* adjectives that are structurally lower in the output.
- b. If a language merges adjuncts at the LOWEST segment of the adjunction site, adjectives that are structurally higher in the output have merged *before* adjectives that are structurally lower in the output.

4.5.7.3 Back to Hebrew

Now, if Hebrew is a language where adjuncts attach at the lowest segment, this means that it is the higher adjective that has merged first. In this way we can understand the mismatch from Hebrew:

- (379) a. ?ha-bealim ha-pratijim ha-axaron šel ha-tmuna haya ?ha-psixoanalitikai
 the-owner the-private.PL the-last.SG of the-painting was.3SG ?the-psychoanalyst
 Jacques Lacan
 Jacques Lacan
- b. *ha-bealim ha-prati ha-axron-im šel ha-tmuna haya/ hayu
 the-owner the-private.SG the-last-PL of the-painting was.3.SG/ was.PL
 ha-psixoanalitikai Jacques Lacan.
 the-psychoanalyst Jacques Lacan
 ‘The last private owner of the painting was the psychoanalyst Jacques Lacan.’

As the derivation proceeds, T agrees with the *iF* of *be'alim*, leaving the *iF* active. At the point when adjuncts merge late into the structure, adjuncts which are higher in the Hebrew

DP merge first, since adjunction targets the lowest segment of the adjunction site. This means that *axaron* merges into the structure before *pratiyim*. When *axaron* merges and the *iF* is active, *axaron* undergoes AGREE-LINK with the *iF* and deactivates it. Thus, when *pratiy* comes to merge into the structure, only *uF* agreement is possible. In the following derivation, I only pay attention to the structure of the DP.

- (380) a. NP
|
owner
- b. Merge *axaron* with lowest segment
- ```

 NP
 / \
 NP axaron
 |
 owner

```
- c. Merge *pratiy* with lowest segment
- ```

      NP
     / \
    NP  axaron
   / \
  NP  pratiy
  |
owner
  
```

The converse mismatch is not possible, since this would require a derivation where *axaron* merges into the structure, and ignores the *iF* of the controller. But, since *iFs* must be agreed with when they are active, this is not possible. It is also not possible to merge *pratiy* into the structure before *axaron*, since this would lead to an incorrect order of adjectives.

- (381) a. NP
|
owner
- b. Merge *pratiy* with lowest segment
- ```

 NP
 / \
 NP pratiy
 |
 owner

```

- c. Merge axaron with lowest segment

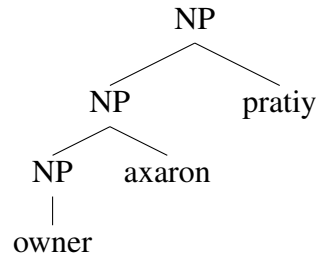

#### 4.5.7.4 Chichewa

Finally, I turn to Chichewa. Firstly consider the data:

- (382) a. ngwazi y-athu y-oyamba  
 hero 9-our 9-first  
 'Our first hero.'
- b. ngwazi w-athu w-oyamba  
 hero 1-our 1-first  
 'Our first hero.'
- c. ngwazi y-athu w-oyamba  
 hero 9-our 1-first  
 'Our first hero.'
- d. \*ngwazi w-athu y-oyamba  
 hero 1-our 9-first  
 INTENDED: 'Our first hero.'

Recall from above that I treat Chichewa as involving a right branching DP-structure:

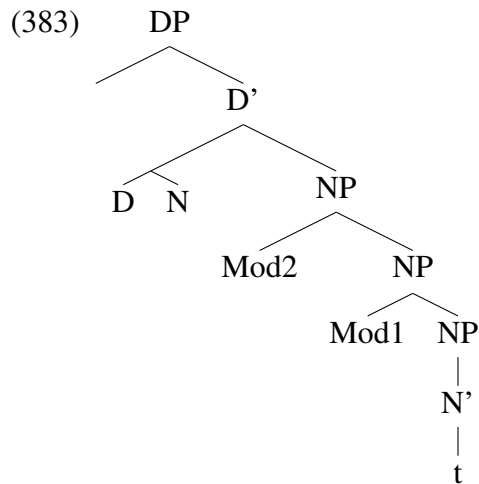

The right branching structure of Chichewa (and Bantu more generally) is supported by the order of the post-nominal modifiers. Firstly, as Carstens (1993) shows, the unmarked order of elements within the Bantu noun phrase is  $N \gg \text{Poss} \gg \text{Adj}$ . Thus, the unmarked order of the modifiers is the same as English. On the other hand, in a language like Hebrew, which has been argued to have the opposite structure to Chichewa, the post-nominal elements show the mirror image of English. The asymmetries between the languages suggests that only the noun moves to the front in Chichewa, leaving the rest of the structure intact, whereas in Hebrew there are successive movements of ever increasing structure.<sup>26</sup>

Now, focusing on Chichewa, we have to understand why the possessive pronoun is allowed to show morphologically agreement, whilst the ordinal numeral is allowed to show semantic agreement. I take it to be fairly uncontroversially the point that the ordinal numeral is an adjunct. If true, then this means that the possessive pronoun in Chichewa will also need to be an adjunct - otherwise it would merge into the derivation before the ordinal (which would late-merge) and could potentially inactivate the *iF* on the noun before the ordinal had a chance to undergo AGREE-LINK. As it happens, whether or not possessive pronouns are adjuncts or not seems to be a point of cross-linguistic variation. Bošković (2005), Despić (2011) shows that possessives in Serbo-Croatian have the same status of adjectives in the language.<sup>27</sup> In Serbo-Croatian, possessives are allowed to bind out of the NP (Despić 2011):

<sup>26</sup>This all rests on the assumption that the order of elements in English is the 'default', i.e. what every structure starts off as, see Kayne (1994), Cinque (1999, 2005), but see also Abels & Neeleman (2012) for a dissenting view.

<sup>27</sup>See also Bošković & Hsieh (2012) on Chinese, which shows the same.

- (384) \*Kusturicin<sub>i</sub> najnoviji film ga<sub>i</sub> je zaista razočarao  
 Kusturica's latest film him is really disappointed  
 'Kusturica<sub>i</sub>'s latest film really disappointed him<sub>i</sub>.'

Despić takes this to show that possessives do not occupy the same structural position as they do in English. In English, a possessive does not give a binding Principle B violation in the same environment:

- (385) John<sub>i</sub>'s mother loves him<sub>i</sub>.

Despić argues that this contrast between the two languages shows that possessives in Serbo-Croatian are not buried within a PossP underneath a DP, but rather the DP layer is lacking altogether in this language, and that possessives adjoin to the NP layer along with adjectives.<sup>28</sup>

In the analysis of Chichewa, I will assume that possessive pronouns are adjuncts in the language, along with ordinal numerals. Now of interest to us is when they combine in the tree with ordinals. Since it is ordinal numerals which have the ability to show semantic agreement in the case of a mismatch, we are forced here to conclude that in Chichewa, ordinals merge into the structure before possessive pronouns. Now, in Chichewa, possessives appear ordinarily closest to the noun, whilst there is a freedom of ordering in modifiers that follow possessives (Sam Mchombo p.c., see also Mchombo 2004). In order to follow the spirit of Carstens (1993), yet adhere to the assumption that possessive pronouns are adjuncts, I adopt the following structure:

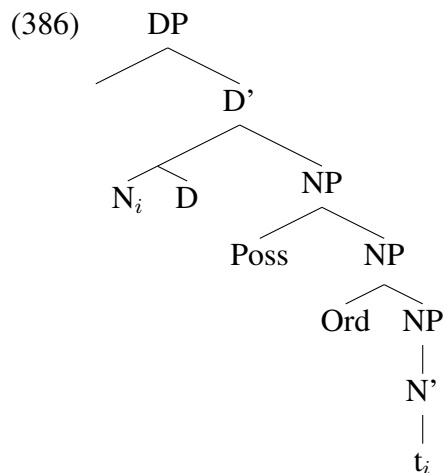

<sup>28</sup>For more discussion on the no-DP analysis of article-less languages, and consequences for the syntax and semantics of these languages, see Bošković (2005, 2009b, 2013), Bošković & Gajewski (2011), Despić (2011), Cheng (2013), Kang (2014), Todorović (In progress).



Possessive pronouns will therefore appear closer to the noun than ordinals. Now, we then see that Chichewa has the opposite parameter setting for where to merge adjuncts than Hebrew does:

(387) In case of adjunction, adjoin to the {highest/lowest} segment of the adjunction site.

This will then mean that ordinal numerals late-merge and adjoin to NP, and then possessives late-merge and adjoin to NP above ordinals. The derivation proceeds as follows:

(388) *NP without adjuncts is created, N moves to D*

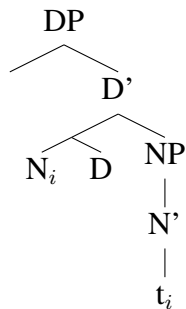

(389) *Ordinal merges to the highest segment of NP*

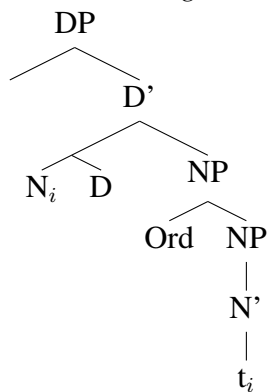

(390) *Possessive merges to highest segment of NP*

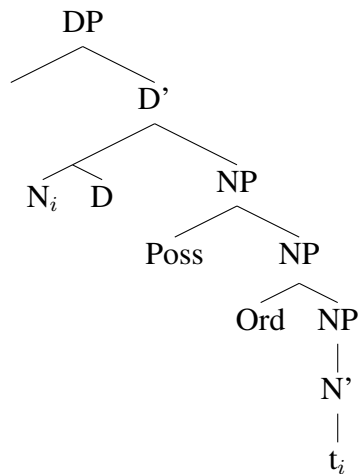

Thus, the mismatch can be created at the point of the derivation of (389). At this point, when the ordinal merges into the structure it will undergo AGREE-LINK with the noun. Supposing that the *iF* on the noun is active, the ordinal will be linked to the *iF* of the noun and show semantic agreement. If the *iF* is inactive, then morphological agreement will be seen. Supposing that the *iF* is active, then the process of AGREE-LINK can potentially deactivate it. If so, then the possessive will only be able to show morphological agreement, since it will not be able to undergo AGREE-LINK with the inactive *iF*. In this instance, we derive the attested mismatch. However, supposing that the *iF* remains active, then we get matching semantic agreement on the ordinal and possessive. Importantly, as we have seen throughout this section, the unattested mismatch is not able to be generated, as it would require the element that merges first to ignore an active *iF*, which is not possible.

## 4.6 Conclusions

Throughout this chapter we have been concerned with the Agreement Hierarchy of Corbett (1979, 1983, 2012). Notably, instead of focusing on the corpus-level validity of the Agreement Hierarchy, we have looked at instances where the Agreement Hierarchy appears to operate as a constraint at the sentential level. Given that the Agreement Hierarchy merely describes the likelihood of semantic agreement versus morphological appearing on given elements within a language, that it would constrain derivations in this way was surprising. Nonetheless, we have seen multiple instances of 3/4 patterns, where mismatches between semantic and morphological agreement are tolerated in only one way.

Throughout the chapter, I have considered various ways in which we can explain these 3/4 patterns. Firstly, I considered the so-called multiple grammars approach, whereby a speaker has multiple competing grammars at their disposal. This approach has its

strengths, as noted above, most notably the fact that it can capture Agreement Hierarchy effects across a corpus, with the gradience that comes with register choice and so on. However, there are problems with this approach when trying to extend it to the 3/4 patterns that hold within a single sentence. In order to account for the sentence internal Agreement Hierarchy effects, one must build in implicational relationships between elements in the grammar, which ultimately only has the effect of recasting the problem elsewhere leaving unanswered the question of *why* such patterns exist.

I also summarized the approach taken in previous work, namely the *Valuation Economy* approach which I appealed to for British English, however noted that whilst this offers a different way of looking at the problem, the exact formulation in Smith (2013) struggled to generalize beyond British English. We then saw that we can understand all 3/4 facts by adopting the formulation of AGREE given in chapter 3, combined with the assumption that AGREE-LINK happens as soon as possible and the ability of AGREE-LINK to deactivate *i*Fs. This allows us to have a principled account of the 3/4 patterns, which ultimately are controlled by the order in which elements merge into the structure.

Once more we should consider whether this picture of AGREE is necessary. At the end of chapter 3, I concluded with discussion of whether the model of AGREE argued for here is a necessity in order to explain the facts from Russian and British English, or whether we can do it in a different way. The conclusion there was that whilst it is possible to analyze the facts of Russian and British English in a different manner, namely whereby agreement that operates within the syntax only looks upwards, but agreement that was post-syntactic can look upwards and downwards. We noted that it was possible to understand the restrictions on semantically motivated agreement compared to morphologically motivated agreement in such a manner, however we do not gain anything over the present analysis.

Thus, in order to compare the two, let's consider how the facts of this chapter bear on the discussion. In fact, we already know that the current model of AGREE fares better than the competitor. Smith (2013) was based on such an approach, supplemented with the condition of *Valuation Economy*, which ensured that agreements happening within the same component had to target the same feature type, *i*F or *u*F, but not both. As discussed above, such an approach works for the 3/4 pattern of British English, but struggles to gain traction beyond that. The *Valuation Economy* approach needs to be further supplemented with an extrinsic ordering of when elements agree in order to capture the attested patterns. However, in doing so, we face the same problem that strikes the multiple grammars approach, namely the Agreement Hierarchy is being restated into our grammatical knowledge without any deeper reason why it should be the case. On the other hand, the model argued for here for AGREE doesn't do that. The Agreement Hierarchy can hold within a single sentence because of the order of merger of elements into the tree. AGREE-LINK happens as soon as possible, and due to the fact that anaphors merge before verbs, and that adjectives,

as adjuncts merge counter-cyclically, we end up with only the attested mismatches being able to be generated, without the need to order anything extrinsically.

# Chapter 5

## Conclusions

Throughout this dissertation I have been concerned with the nature of features, and how the study of mismatches between morphology and semantics leads to new insights into other aspects of the grammar. I have argued that looking at the mass/count distinction in these terms leads to a novel analysis of certain atypical mass nouns in both Telugu and English. Furthermore, I have argued that the results in this study bear on the nature of agreement itself, adding further to the literature that argues that agreement should be seen as a two-step operation, that is (potentially, at least) distributed across two separate domains in the grammar, syntax and PF.

As is always the case, there are many questions that remain open and deserve careful attention in future research. In particular, the claim given here that semantic agreement is possible only in a Reverse Agree configuration makes very clear, testable predictions about where semantic agreement is going to be licensed in a given language. In this respect, the data given in Glushan (2013) seem to show that this view is too restrictive, and that we need a mechanism that allows for semantic agreement to also look downwards, but only in a restrictive manner. To the extent that the Russian data and the British English data are illustrating the same phenomenon, then further work needs to be done to unify the two positions into a full theory of semantic agreement. I leave this open to future research, in the hope that other data will be found and force the issue one way or another. What can be taken away from all of this is the proposal that agreement that targets an *i*F is different from agreement that targets a *u*F, both in terms of locality and where it happens in the derivation.

Another issue which I have taken up is the nature of the mass/count distinction. There is obviously much more that can be said about the mass/count distinction than I have been able to pay attention to. However, I do make predictions that will be testable. The split between *i*Fs and *u*Fs produces fake mass nouns in English and the converse situation in

Telugu, and looking beyond these languages, we predict more instances of mass nouns that look like count nouns, and vice versa. I have also made a strong prediction regarding quantifier allomorphy in the mass/count distinction: allomorphy should not be conditioned by *i*Fs. That is, wherever there is quantifier allomorphy in the mass/count distinction, it should pay attention to the morphological shape of the noun rather than the semantics. Fake mass nouns, and *niiLLu* and *paalu* show that this is the case for these nouns, and at the end of chapter 2 I discussed plural mass nouns in English and middle-class nouns in Purépecha to provide additional evidence that the prediction holds.

The final point of note is that I have been discussing semantic agreement only in terms of when and where an *i*F can be targeted, and what this suggests about the timing and nature of AGREE. I have however, (happily) ignored many complicated questions along the way. AGREE, in its original formulation, was a facilitator of both movement and case assignment, two things I have not discussed at all here. Agreement does appear to be intimately linked with various operations of the grammar, not only movement and case assignment, and it is an open question how semantic agreement plays into all this. Take for instance movement. In Chomsky (2000, 2001), movement is invoked in order to satisfy an EPP feature on the projection that is targeted by movement. This approach to movement faces several problems as is well discussed. In attempting to fix the problem, Bošković (2007) proposes that an uninterpretable feature forces movement of the element that it is located on in order to get it into a configuration (downward Agree) where it could be checked off. The minutiae of each approach to movement is not relevant, but what can be seen is that movement has largely been taken to be feature driven in Minimalist research. I however have been using a different sense of *u*F and *i*F than what is commonly assumed, making no commitment to whether *u*F status bestows upon some feature anything other than being legible to the morphological component. Once we take this version of features however, it remains to be seen whether we ought to build anything further into *u*Fs that would give them certain behaviors, or whether we should search for another conception of movement altogether. Certainly, if the former, then it needs to be investigated whether *i*Fs might end up driving movement too.

In sum, this dissertation has argued for a particular view of features where they are split into a morphological half and a semantic half. The general case is that these two values on a feature line up, however we have noted numerous instances where they do not. Importantly, we have seen that the *i*F and the *u*F are accessed differently by the syntax, in that the *i*F is only available to factor into agreement if the entire process of AGREE (both AGREE-LINK and AGREE-COPY) happens within the syntax, and crucially in this instance only if the *i*F c-commands the target. For *u*Fs, there is no such restriction. From this relatively simple view stem various consequences for various for the architecture of different components like syntax and morphology, as well as Universal Grammar as a

whole. There remains much work to be done in order to explore and understand where all of these consequences lead, and this dissertation is just the tip of the iceberg in this realm.

# Bibliography

- Abels, Klaus & Ad Neeleman (2012) Linear Asymmetries and the LCA. *Syntax* **15**(1): 25–74.
- Acquaviva, Paulo (2008a) *Lexical Plurals: A morphosemantic approach*. Oxford Studies in Theoretical Linguistics, Oxford University Press.
- Acquaviva, Paulo (2008b) Roots and lexicality in Distributed Morphology. <http://ling.auf.net/lingbuzz/000654> .
- Adger, David (2003) *Core Syntax*. Oxford University Press.
- Alexiadou, Artemis, Elena Anagnostopoulou, & Susanne Wurmbrand (2014) Movement vs. long distance Agree in raising: Disappearing phases and feature valuation. In *Proceedings of the North East Linguistic Society 43*, Hsin-Lun Huang, Ethan Poole, & Amanda Rysling, eds., 1–12.
- Anand, Pranav & Andrew Nevins (2004) Shifty Operators in Changing Contexts. *Proceedings from Semantics and Linguistic Theory* **14**: 20–37.
- Arregi, Karlos & Andrew Nevins (2012) *Morphotactics: Basque Auxiliaries and the Structure of Spellout*. Dordrecht: Springer.
- Bailyn, John Frederick (2001) On scrambling: A reply to Bošković and Takahashi. *Linguistic Inquiry* **32**(4): 635–658.
- Bailyn, John Frederick (2004) Generalized Inversion. *Natural Language and Linguistic Theory* **22**(1): 1–49.
- Baker, Mark (2008) *The syntax of agreement and concord*. Cambridge: Cambridge University Press.
- Bale, Alan, Michael Gagnon, & Hrayr Khanjian (2011) On the relationship between morphological and semantic markedness. *Morphology* **21**(2): 197–221.



- Bale, Alan C. & David Barber (2009) The Interpretation of Functional Heads: Using Comparatives to Explore the Mass/Count Distinction. *Journal of Semantics* **26**(3): 217–252.
- Barner, David & Jesse Snedeker (2005) Quantity judgements and individuation: evidence that mass nouns count. *Cognition* **97**: 41–66.
- Benmamoun, Elabbas, Archana Bhatia, & Maria Polinsky (2009) Closest conjunct agreement in head final languages. *Linguistic Variation Yearbook* **9**: 67–88.
- Bhatt, Rajesh (2005) Long-distance agreement in Hindi-Urdu. *Natural Language and Linguistic Theory* **23**: 757–807.
- Bhatt, Rajesh (2012) Differential phrases and degree variables. Talk given at ConSOLE XX, Leipzig.
- Bhatt, Rajesh & Martin Walkow (2013) Locating agreement in grammar: An argument from conjunctions. *Natural Language and Linguistic Theory* **31**: 951–1013.
- Bobaljik, Jonathan D. (1995) *Morphosyntax: The Syntax of Verbal Inflection*. Ph.D. thesis, MIT.
- Bobaljik, Jonathan D. (2002) A-Chains at the PF-Interface: Copies and Covert Movement. *Natural Language and Linguistic Theory* : 197–267.
- Bobaljik, Jonathan D. (2004) Topics in Agreement, unpublished class notes.
- Bobaljik, Jonathan D. (2008) Where's phi? In *Phi-theory: phi-features across modules and interfaces*, Daniel Harbour, David Adger, & Susanna Béjar, eds., Oxford Studies in Theoretical Linguistics, Oxford: Oxford University Press, 295–328.
- Bobaljik, Jonathan D. & Susi Wurmbrand (2005) The Domain of Agreement. *Natural Language and Linguistic Theory* **23**(4): 809–865.
- Bobaljik, Jonathan D. & Cynthia Levart Zocca (2011) Gender markedness: the anatomy of a counter-example. *Morphology* **21**(2): 141–166.
- Borer, Hagit (2005) *Structuring Sense vol 1: In Name Only*. Oxford University Press.
- Bošković, Željko (1997) *The syntax of nonfinite complementation: an economy approach*. Cambridge, MA: MIT Press.
- Bošković, Željko (2002) Clitics as Nonbranching Elements and the Linear Correspondence Axiom. *Linguistic Inquiry* **33**(2): 329–340.

- Bošković, Željko (2005) On the Locality of Left Branch Extraction and the Structure of NP. *Studia Linguistica* 59(1): 1–45.
- Bošković, Željko (2006a) Case agreement with genitive of quantification in Russian. In *Agreement systems*, Cedric Boeckx, ed., Amsterdam/Philadelphia: John Benjamins, 99–121.
- Bošković, Željko (2006b) Case Checking versus Case Assignment and the Case of Adverbial NPs. *Linguistic Inquiry* 37(3): 522–533.
- Bošković, Željko (2007) On the Locality and Motivation of Move and Agree: An Even More Minimal Theory. *Linguistic Inquiry* 38(4): 589–644.
- Bošković, Željko (2009a) Licensing negative constituents and negative concord. In *Proceedings of NELS 38*.
- Bošković, Željko (2009b) Unifying first and last conjunct agreement. *Natural Language and Linguistic Theory* 27(3): 455–496.
- Bošković, Željko (2011) On valued uninterpretable features. In *Proceedings of NELS 39*.
- Bošković, Željko (2013) Phases beyond clauses. In *The Nominal Constructinos in Slavic and Beyond*, Lilia Schürcks, Anastasia Giannakidou, & Urtzi Etxeberria, eds., Berlin: Mouton de Gruyter.
- Bošković, Željko & Jon Gajewski (2011) Semantic correlates of the NP/DP parameter. In *Proceedings of NELS 39*.
- Bošković, Željko & I-Ta Hsieh (2012) On word order, binding relations and plurality within Chinese NPs. In *Proceedings of IsCCL 13*.
- Carstens, Vicki (1991) *The morphology and syntax of determiner phrases in Kiswahili*. Ph.D. thesis, University of California Los Angeles.
- Carstens, Vicki (1993) On nominal morphology and DP structure. In *Theoretical Aspects of Bantu Grammar*, Sam A. Mchombo, ed., Leland Stanford Junior University.
- Chandra, Pritha (2007) Long-distance agreement in Tsez: A reappraisal. In *University of Maryland Working Papers in Linguistics*, vol. 15, A. Cònroy, C. Jing, C. Nakao, & E. Takahashi, eds., 47–72.
- Cheng, Hu-Tse (2013) *Argument Ellipsis, Classifier Phrases, and the DP Parameter*. Ph.D. thesis, University of Connecticut.

- Cheng, Lisa, Jenny Doetjes, & Rint Sybesma (2008) How universal is the Universal Grinder? *Linguistics in the Netherlands* : 50–62.
- Chierchia, Gennaro (1998) Plurality of mass nouns and the notion of 'semantic parameter'. In *Events and grammar*, Susan Rothstein, ed., Dordrecht: Kluwer, 53–103.
- Chierchia, Gennaro (2010) Mass nouns, vagueness and semantic variation. *Synthese* **174**: 99–149.
- Chomsky, Noam (1981) *Lectures on Government and Binding*. Dordrecht: Foris.
- Chomsky, Noam (1995) *The Minimalist Program*. Cambridge, MA: MIT Press.
- Chomsky, Noam (2000) Minimalist inquiries. In *Essays on minimalist syntax in honor of Howard Lasnik*, Roger Martin, David Michaels, & Juan Uriagereka, eds., Cambridge, MA: MIT Press, 89–155.
- Chomsky, Noam (2001) Derivation by phase. In *Ken Hale: A life in language*, Michael Kenstowicz, ed., Cambridge, MA: MIT Press, 1–52.
- Cinque, G. (1999) *Adverbs and Functional Heads: A Cross-Linguistic Perspective*. Oxford: Oxford University Press.
- Cinque, G. (2005) Deriving Greenberg's Universal 20 and its exceptions. *Linguistic Inquiry* **36**: 315 – 332.
- Cinque, G. (2010) *The syntax of adjectives*. Cambridge, MA: MIT Press.
- Collins, Chris & Paul Postal (2012) *Imposters: A study of pronominal agreement*. MIT Press, Cambridge, MA.
- Corbett, Greville (1979) The agreement hierarchy. *Journal of Linguistics* **15**: 203–935.
- Corbett, Greville (1983) *Hierarchies, targets and controllers: Agreement patterns in Slavic*. Penn State Publishing.
- Corbett, Greville (1991) *Gender*. Cambridge: Cambridge University Press.
- Corbett, Greville (2000) *Number*. Cambridge: Cambridge University Press.
- Corbett, Greville (2012) *Features*. Cambridge: Cambridge University Press.
- Creemers, Ava, Jan Don, & Paula Fenger (2015) A Distributed Morphology analysis of stress-sensitivity and flexibility, manuscript.

- Dalrymple, Mary & Robert Kaplan (1997) A set-based approach to feature resolution. In *Proceedings of the LFG 97 Conference*, Miriam Butt & Tracy Holloway King, eds., San Diego: CSLI.
- de Belder, Marijke (2011) *Roots and affixes: eliminating lexical categories from syntax*. Ph.D. thesis, Utrecht.
- de Belder, Marijke (2013) Collective mass affixes: When derivation restricts functional structure. *Lingua* .
- den Dikken, Marcel (1995) Binding, expletives and levels. *Linguistic Inquiry* **26**(2): 347–354.
- den Dikken, Marcel (2001) Plurilinguals, pronouns and quirky agreement. *The Linguistic Review* **18**(1): 19–41.
- den Dikken, Marcel (2007) *Relators and Linkers*. Cambridge: MIT Press.
- Despić, Miloje (2011) *Syntax in the absence of Determiner Phrase*. Ph.D. thesis, University of Connecticut.
- Diesing, Molly (1992) *Indefinites*. Cambridge, MA: MIT Press.
- Doetjes, Jenny (1997) Mass and Count: syntax or semantics? *Proceedings of meaning on the HIL* : 34–52.
- Eberhard, K. M. (1997) The marked effect of number on subject-verb agreement. *Journal of Memory and Language* **36**: 147–164.
- Elbourne, Paul (1999) Some correlations between semantic plurality and quantifier scope. In *Proceedings of NELS 29*, 81–92.
- Embick, David & Morris Halle (2005) *On the Status of Stems in Morphological Theory*. Netherlands.
- Epstein, Samuel & T. Daniel Seely (1999) SPEC-ifying the GF “subject:” eliminating A-Chains and the EPP within a Derivational Model. Ms. University of Michigan.
- Fox, Danny (1999) Reconstruction, binding theory and the interpretation of chains. *Linguistic Inquiry* **30**(2): 157–196.
- Fox, Danny (2000) *Economy and semantic interpretation*. Cambridge: MIT Press.

- Fox, Danny & David Pesetsky (2005) Cyclic linearization of syntactic structure. *Theoretical Linguistics* **31**: 1–45.
- Franks, Steven (1994) Parametric properties of numeral phrases in Slavic. *Natural Language and Linguistic Theory* **12**: 597–674.
- Franks, Steven (1995) *Parameters of Slavic Morphosyntax*. Oxford Studies in Comparative Syntax, Oxford: Oxford University Press.
- Gillon, Brendon (1992) Towards a common semantics for English count and mass nouns. *Linguistics and Philosophy* **15**(6): 597–639.
- Glushan, Zhanna (2013) *The role of animacy in Russian morphosyntax*. Ph.D. thesis, University of Connecticut.
- Hahm, Hyun-Jong (2010) *A cross-linguistic study of syntactic and semantic agreement: Polite plural pronouns and other issues*. Ph.D. thesis, University of Texas at Austin.
- Halle, Morris & Alec Marantz (1993) Distributed Morphology and the Pieces of Inflection. In *The View from Building 20*, Ken Hale & Samuel Jay Keyser, eds., Cambridge, MA: MIT Press, 111–176.
- Harbour, Daniel (2007) *Morphosemantic number: From Kiowa noun classes to UG number features*. Springer.
- Harbour, Daniel (2011) Valence and Atomic Number. *Linguistic Inquiry* **42**(4): 561–594.
- Harbour, Daniel (2014) Paucity, abundance, and the theory of number. *Lingua* **90**(1): 185–229.
- Hazout, Ilan (2004) The syntax of existential constructions. *Linguistic Inquiry* **35**(3): 393–430.
- Heycock, Caroline (1995) Asymmetries in reconstruction. *Linguistic Inquiry* **26**(4): 547–570.
- Hicks, Glyn (2009) *The derivation of anaphoric relations*. Amsterdam/Philadelphia: John Benjamins.
- Hippisley, Andrew, Marina Chumakina, Greville G. Corbett, & Dunstan Brown (2004) Suppletion: frequency, categories and distribution of stems. *Studies in Language* **28**(2): 387–418.

- Höhn, Georg (2012) *Unagreement is an illusion*. Master's thesis, University College London.
- Hualde, Jose Ignacio (1992) Metaphony and count/mass morphology in Asturian and Cantabrian dialects. In *Theoretical analyses in Romance linguistics: selected papers from the nineteenth Linguistic Symposium on Romance Languages (LSRL XIX)*.
- Huddleston, Rodney & Geoffrey K. Pullum (2002) *The Cambridge Grammar of the English Language*. Cambridge University Press.
- Kang, Jungmin (2014) *On the absence of TP and its consequences: Evidence from Korean*. Ph.D. thesis, University of Connecticut.
- Kayne, Richard (1994) *The Antisymmetry of Syntax*. Cambridge, MA: MIT Press.
- Kihm, A. (2005) Noun class, gender and the lexicon-syntax-morphology interfaces: a comparative study of Niger-Congo and Romance languages. In *The Oxford handbook of comparative syntax*, G. Cinque & R. Kayne, eds., Oxford: Oxford University Press.
- Koopman, Hilda (2005) Agreement: in defence of the “Spec-head configuration”. In *Agreement systems*, Cedric Boeckx, ed., John Benjamins.
- Kramer, Ruth (2009) *Definite markers, phi-features and agreement*. Ph.D. thesis, University of California, Santa Cruz.
- Kramer, Ruth (2014) Gender in Amharic: A Morphosyntactic Approach to Natural and Grammatical Gender. *Language Sciences* **43**: 102–115.
- Krifka, M. (1992) Thematic Relations as Links between Nominal Reference and Temporal Thematic relations as links between nominal reference and temporal constitution. In *Lexical Matters*, Ivan Sag & Anna Szabolsci, eds., Stanford: CSLI, 29–53.
- Krishnamurti, B. & J. Gwynn (1985) *A Grammar of Modern Telugu*. Oxford University Press.
- Landau, Idan (2000) *Elements of control: structure and meaning in infinitival constructions*. Studies in Natural Language and Linguistic Theory, Dordrecht: Kluwer.
- Landau, Idan (to appear) DP-internal semantic agreement: A configurational analysis. *Natural Language and Linguistic Theory* .
- Landman, Fred (1989a) Groups, I. *Linguistics and Philosophy* **12**: 559–605.

- Landman, Fred (1989b) Groups, II. *Linguistics and Philosophy* **12**: 723–744.
- Lasnik, Howard (1989) *Essays on Anaphora*. Dordrecht: Kluwer.
- Lasnik, Howard (1995) Case and expletives revisited: on greed and other human failings. *Linguistic Inquiry* **26**(4): 615–633.
- Lavine, James & Robert Freidin (2001) The subject of defective tense in Russian. *Journal of Slavic Linguistics* **9**: 253–290.
- Lebeaux, David (1988) *Language acquisition and the form of the grammar*. Ph.D. thesis, University of Massachusetts Amherst.
- Leko, N. (1998) Functional categories and the structure of the DP in Bosnian. In *Topics in South-Slavic syntax and semantics*, M. Dimirova-Vulchanova & L. Hellan, eds., Amsterdam: John Benjamins.
- Levin, Magnus (2001) *Agreement with collective nouns in English*, *Lund Studies in English*, vol. 103. Lund University.
- Lima, Suzi (2014) *The grammar of individuation and counting*. Ph.D. thesis, University of Massachusetts Amherst.
- Link, Godehard (1983) The logical analysis of plurals and mass terms: A lattice theoretical approach. In *Meaning, use and interpretation of language*, C. Schwarze R. Bäuerle & A. von Stechow, eds., Berlin: Walter de Gruyter.
- Lowenstamm, Jean (2010) Derivational affixes as roots (phasal spellout meets English stress shift), manuscript, Universit'e Paris-Diderot & CNRS.
- Maldonado, Violeta Vázquez Rojas (2012) *The syntax and semantics of Purépecha noun phrases and the mass/count distinction*. Ph.D. thesis, NYU.
- Marantz, Alec (1995) A late note on late insertion. In *Explorations in Generative Grammar*, Young-Sun Kim, ed., Seoul: Hankuk Publishing Co., 396–413.
- Marušič, Franc, Andrew Nevins, & William Badecker (2015) The grammars of conjunctive agreement in Slovenian. *Syntax* **18**(1): 39–77.
- Mathieu, Eric (2012) Flavors of division. *Linguistic Inquiry* **43**(4): 650–679.
- Mchombo, Sam A. (2004) *The syntax of Chichewa*. Cambridge University Press.

- Moskal, Beata (2015a) *Domains on the border: Between Morphology and Phonology*. Ph.D. thesis, University of Connecticut, Storrs, CT.
- Moskal, Beata (2015b) Limits on allomorphy: A case-study in nominal suppletion. *Linguistic Inquiry* **46**(2): 363–375.
- Munn, Alan (1993) *Topics in the syntax and semantics of coordinate structures*. Ph.D. thesis, University of Maryland.
- Ojeda, A. (2005) The paradox of mass plurals. In *Polymorphous Linguistics: Jim McCawley's Legacy*, Elaine Francis Salikoko Mufwene & Rebecca Wheeler, eds., Cambridge, MA: MIT Press, 389–410.
- Pesetsky, David (1982) *Paths and categories*. Ph.D. thesis, MIT, Cambridge, MA.
- Pesetsky, David (2012) Russian Case Morphology and the Syntactic Categories, ling-Buzz/001120.
- Pesetsky, David & Esther Torrego (2007) The syntax of valuation and the interpretation of features. In *Phrasal and clausal architecture*, V. Samiian S. Karimi & W. Wilkins, eds., John Benjamins, 262–294.
- Phillips, Colin (2003) Linear order and constituency. *Linguistic Inquiry* **34**(1): 37–90.
- Polinsky, Maria & Eric Potsdam (2001) Long-distance agreement and topic in Tsez. *Natural Language and Linguistic Theory* **19**: 583–646.
- Pollard, Carl & Ivan Sag (1992) Anaphors in English and the scope of Binding Theory. *Linguistic Inquiry* **23**(2): 261–303.
- Pollard, Carl & Ivan Sag (1994) *Head driven phrase structure grammar*. Chicago, IL: The University of Chicago Press.
- Preminger, Omer (2011) *Agreement as a fallible operation*. Ph.D. thesis, MIT, Cambridge, MA.
- Preminger, Omer (2015) *Agreement and its failures*. Cambridge, MA: MIT Press.
- Reinhart, Tanya & Eric Reuland (1993) Reflexivity. *Linguistic Inquiry* **24**(4): 657–720.
- Reuland, Eric (2001) Primitives of binding. *Linguistic Inquiry* **32**(3): 439–492.
- Reuland, Eric (2011) *Anaphora and Language Design*. Cambridge, MA: MIT Press.



- Robblee, K. (1993) Individuation and Russian agreement. *The Slavic and Eastern European Journal* **37**(4): 423–441.
- Rooryck, Johan & Guido Vanden Wyngaerd (2011) *Dissolving Binding Theory*. Oxford Studies in Theoretical Linguistics, Oxford: Oxford University Press.
- Rothstein, Susan (2010) Counting and the mass/count distinction. *Journal of Semantics* **27**: 343–397.
- Sauerland, Uli (1998) Scope freezing. In *Proceedings of the North East Linguistic Society* 28, 169–182.
- Sauerland, Uli (2004a) "A team," definitely. *Snippets* **9**: 11–12.
- Sauerland, Uli (2004b) *A Comprehensive Semantics for Agreement*. Berlin: Ms. ZAS.
- Sauerland, Uli (2008) On the semantic markedness of Phi-features. In *Phi-Features*, Daniel Harbour, David Adger, & Susana Bejar, eds., Oxford: Oxford University Press, 57–82.
- Schutze, Carson T. (1999) English expletive constructions are not infected. *Linguistic Inquiry* **30**(3): 467–484.
- Schwarzschild, Roger (1996) *Pluralities*. Dordrecht: Kluwer.
- Schwarzschild, Roger (2011) Stubborn distributivity, multiparticipant nouns and the count/mass distinction. In *Proceedings of NELS39*, Brian Smith Suzi Lima, Kevin Mullin, ed., 661–678.
- Sichel, Ivy (2002) Phrasal movement in Hebrew adjectives and possessives. In *Dimensions of movement: From features to remnants*, Sjef Barbiers Artemis Alexiadou, Elena Anagnostopoulou & Hans-Martin Gärtner, eds., Amsterdam: John Benjamins.
- Smith, Peter W. (2013) The syntax of semantic agreement in British English. *Manuscript, University of Connecticut* .
- Sobin, Nicholas (1997) Agreement, default rules, and grammatical viruses. *Linguistic Inquiry* **28**(2): 318–343.
- Solt, Stephanie (2009) *The semantics of adjectives of quantity*. Ph.D. thesis, City University of New York.
- Stepanov, Arthur (2000) The timing of adjunction. In *Proceedings of NELS 30*.

- Stepanov, Arthur (2001) Late adjunction and minimalist phrase structure. *Syntax* **4**(2): 94–125.
- Todorović, Neda (In progress) *On the Presence/Absence of TP: Syntactic properties and temporal interpretation*. Ph.D. thesis, University of Connecticut.
- Tsoulas, George (2007) On the grammar of number and mass terms in Greek. *MIT Working Papers in Linguistics* **49**: 239–266.
- van Koppen, Marjo (2005) *One probe - two goals: aspects of agreement in Dutch dialects*. Ph.D. thesis, University of Leiden.
- Van Koppen, Marjo (2012) The distribution of phi-features in pronouns. *Natural Language and Linguistic Theory* **30**: 135–177.
- van Koppen, Marjo & Johan Rooryck (2008) Resolving resolution: Underspecification and the law of coordination of likes, manuscript.
- Watanabe, Akiro (2010) Vague quantity, numerals, and natural numbers. *Syntax* **13**(1): 37–77.
- Wechsler, Stephen & Hyun-Jong Hahm (2011) Polite plurals and adjective agreement. *Morphology* **21**: 247–281.
- Wechsler, Stephen & Larisa Zlatić (2000) A theory of agreement and its application to Serbo-Croatian. *Language* **76**(4): 799–832.
- Wechsler, Stephen & Larisa Zlatić (2003) *The many faces of agreement*. Stanford.
- Wiltschko, Martina (2008) The syntax of non-inflectional plural marking. *Natural Language and Linguistic Theory* **26**: 639–694.
- Wiltschko, Martina (2012) Decomposing the Mass/Count distinction: Evidence from languages that lack it. In *Count and Mass across languages*, Oxford Studies in Theoretical Linguistics, Oxford University Press, 120–146.
- Witkós, J. (2004) Raising expletives. In *Poznań Studies in Contemporary Linguistics*, 175–195.
- Wurmbrand, Susanne (2011) Reverse Agree. *Manuscript, University of Connecticut* .
- Wurmbrand, Susanne (2012a) Agreement: Looking up or down? Talk given at MIT, March 2012.

- Wurmbrand, Susanne (2012b) The syntax of valuation in auxiliary-participle constructions. In *Proceedings of the 29th West Coast Conference on Formal Linguistics*, Jaehoon Choi et al, ed., Tucson: University of Arizona, 154–162.
- Wurmbrand, Susanne (2014a) The merge condition: a syntactic approach to selection. In *Minimalism and beyond: radicalizing the interfaces*, Peter Kosta, Lilia Schürcks, Steven Franks, & Teodora Radev-Bork, eds., Amsterdam: John Benjamins, 139–177.
- Wurmbrand, Susanne (2014b) Tense and aspect in English infinitives. *Linguistic Inquiry* **45**(3): 403–447.
- Zaenen, A., J. Maling, & H. Thráinsson (1985) Case and the grammatical functions: The Icelandic passive. *Natural Language and Linguistic Theory* **3**: 441–483.
- Zeijlstra, Hedde (2004) *Sentential negation and negative concord*. Ph.D. thesis, University of Amsterdam.
- Zeijlstra, Hedde (2012) There is only one way to agree. *The Linguistic Review* **29**: 491 – 539.